

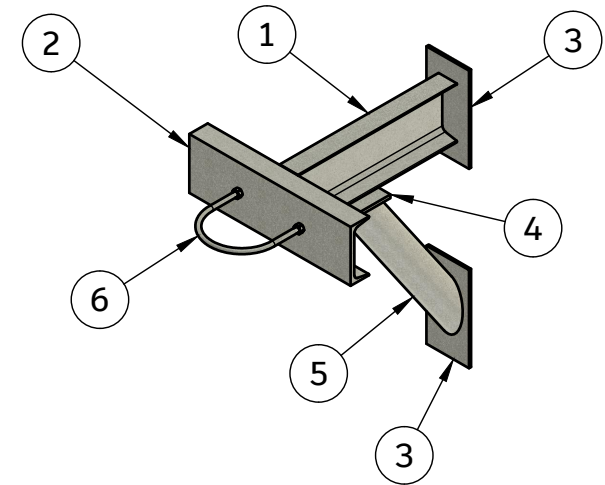

TAG LIST
PSB366
PSB367
PSB368

PARTS LIST					
ITEM	QTY	PART NUMBER	DESCRIPTION	MATERIAL	MASS
1	1	27M1	C6X13 X 20 7/16	STEEL, GALVANIZED	----
2	1	27M2	C6X13 X 19	STEEL, GALVANIZED	----
3	2	27P1	1/4" PL 5 X 10	STEEL, GALVANIZED	----
4	1	27P2	3/8" PL 5 X 5	STEEL, GALVANIZED	----
5	1	27M3	3" SCH 40 X 23 15/16	STEEL, GALVANIZED	----
6	1	6-7.25 U-BOLT	1/2" DIA W/ (4) HN	STEEL, GALVANIZED	----

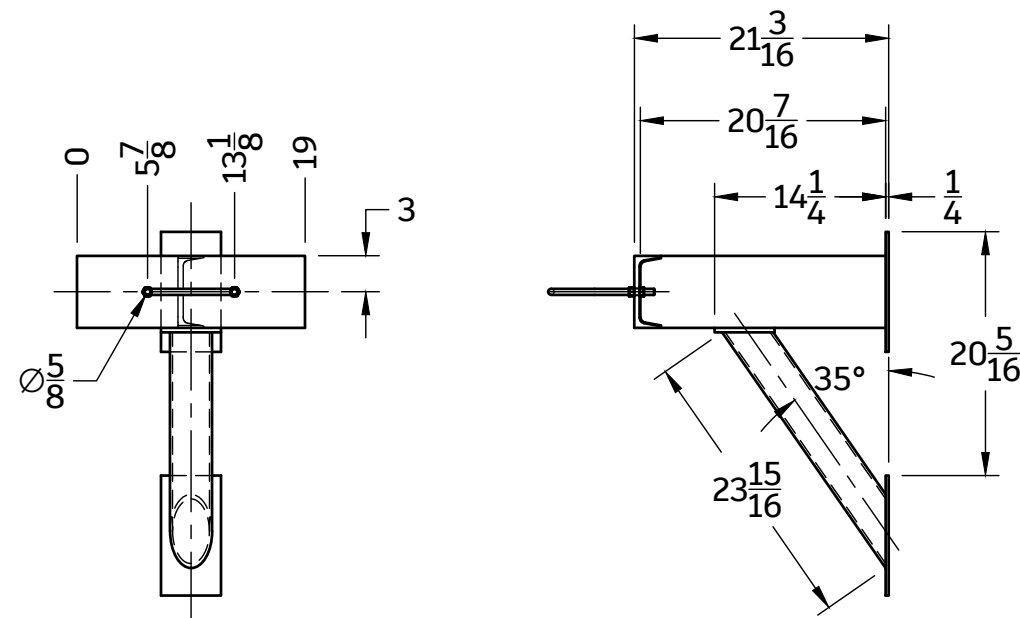

3 REQ

NOTES:
1. ALL FABRICATED STEEL TO BE HOT DIP GALVANIZED.

 <p>SEALS WELDING & FABRICATING 2053 US HWY 78W OXFORD, AL 36203 256-835-0544</p>	PROJECT 7421 MECH. PIPE SUPPORTS		
	TITLE PS27		
www.sealsweldingandfabricating.com	MECHANICAL PIPE SUPPORTS - PLANT BOWEN		
APPROVED	SIZE	JOB#	DWG NO
CHECKED	B	7421	
DRAWN Jarred Driggers 6/1/2023	SCALE 1:16	WEIGHT	SHEET 1/1