

# **STANDARD DESCRIPTION FOR STEEL STRUCTURE PIECES FOR THE NUMERICAL CONTROLS**

Recommendations of the DSTV commission

July 1998  
(7. St Edition)

This Version delete and replace all the previous ones.

Edited by:

Jan-Peter Gutsch  
Ulrich Kammertöns  
Jurgen Keil  
Dieter Knierim  
Dr. Heinz-Günter Liekweg  
Ulrich Pfingst  
Frank Streit  
Jan Verlies  
Bernhard Wiefel  
Jochen Zühlke

English translation done by BSI S.A. B4560 Ocquier tel 00 32 86 349191  
Version 980511

In case of problems, only the german version is valid.

## Standard description for steel structure pieces for the numerical controls.

Dipl.-Math. Jan-Peter Gutsch, Dipl.-Ing. Ulrich Kammertöns, Dipl.-Ing. Jürgen Keil, Ing. (grad.) Dieter Knierim,  
Dr. -Ing. Heinz-Günter Liekweg, Dipl.-Ing. Ulrich Pfingst, Frank Streit, Jan Verlies,  
Dipl.-Ing. Bernhard Wiefel, Dipl.-Ing. Jochen Zühlke

### Table of contents:

<b>News of the 7<sup>th</sup> Corrected Edition .....</b>	
<b>Foreword .....</b>	
<b>Recommendation for futur users of the DSTV .....</b>	
<b>Generalities .....</b>	
<b>Interface File.....</b>	
<b>Units.....</b>	
<b>Used Profils .....</b>	
<b>The Coordinates System of the Piece .....</b>	
<b>System of Coordinates of the Standard Views .....</b>	
<b>Compensation of the Tolerances of Rolling .....</b>	
<b>Header Data .....</b>	
<b>Saw Length .....</b>	
<b>Skew Cuts .....</b>	
<b>Bloc List of Holes.....</b>	
<b>Complete Holes, Non Complete Holes &amp; Countersink Holes .....</b>	
<b>Bloc Marks by Powder or by Punch .....</b>	
<b>Bloc Numeration .....</b>	
<b>Bloc External &amp; Internal Contour .....</b>	
<b>Welding Preparation (Forming of the edges) .....</b>	
<b>Notches .....</b>	
<b>Bloc Cut (Saw, Cutting) .....</b>	
<b>Bloc Tolerance .....</b>	
<b>Bloc Camber ( Preform ).....</b>	
<b>Bloc Plane Definition .....</b>	
<b>Bloc Bended Parts .....</b>	
<b>Bloc Profile (Own User Profile Sections) .....</b>	
<b>Bloc Informations .....</b>	
<b>Example:.....</b>	

## News of the 7<sup>th</sup> Corrected Edition

- This page, gives the list of the news of the 7<sup>th</sup> Edition
- The table of contents (Page 1) and a new structure by theme
- Annulment of the limitation of 8 Characters for the filenames (Page 4)

Because the used Operating Systems allows to use longer filenames , the old limitation has no reason to stay.

- Handling of Comments (Page 5, Table of the Blocs Codes)

The Comments must be taken in account by the programs for in case where, the Interface is exported again. They must be placed in the same place with the same form in the new interface, they cannot be lost. Some new Comments can be introduced.

- Code for left threaded (Page 10)

The List of Codes for Complete Holes, Threaded, Marking as. Punch or Countersink has been elongated with the Code **I** for the left threaded.

- Adjustment for External and Internal Contours (Page 13)

All Contours must be closed, it means that the coordinates X and Y of the first and the last points of the Contour must be the same. All other Points of the Contour must be present only once.

- **Bloc Plane Definition** (Page 16 ff.)

In the **Bloc Profil** the user can define its own Profile Sections, but without the possibility to describe the Geometries as Holes, Internal Contours or Marking of number in all the faces of these profiles. This Problem also appears for the Standard Profile type as Round and Rounded Tube (pipes).

The **Bloc Plane Definition** brings now the solution.

### General Comments

#### Handling for alternative Descriptions possibilities of Geometries

When for one Geometrie more than one Interpretation of the Interface exists, **It MUST** be taken into account the Interpretation with the lower priority, it means for example that:

- one Hole, which can be described by the Bloc **BO** , can only be described by this Bloc. The use of the Bloc **IK** (Internal Contour) is in this case totally forbidden.
- The use of the Bloc **AK** has higher priority that the Bloc **SC**.

#### About Theme Skew Cuts and Bloc External Contour

Contrarily to the previous version the Interface asks that the Skew Cuts must be described in the header data, also when the modifications of the External Contours needs other types of the Bloc **AK**. Other Contour Elements have the value 0.0 at this place in the header data.

## Foreword

It is a standard interface for the geometrical description of the steel structure pieces for the post-processors with numerical control:

Saw  
 Drill  
 Flame Cutting  
 Puncher  
 ...

The essential aim of this interface is to be neutral, it means that with only one standard description we can manage several different NC machines.

The interface standardizes the link between a CAD-program or a graphical system, via a CAM-file for the NC machines.

The geometry of the piece is introduced completely neutrally and after knowing the parameters of the NC machine the post-processor can translate this neutral language to the NC machine language.

The external contour of a beam can be given either by the Code bloc SC (cut) or by the Code bloc AK (external contours of the flanges and the web) but to eliminate any contradictions we recommend to use only one of these two blocs.

At the beginning of this interface, we start with the traditional way which describes the external contours.

The Bloc **SC** was created for the description of special 3D cuts which cannot be described by the description of external contours because for example several and different welding preparation can be located on one edge of the piece.

## Recommendation for futur users of the DSTV

The factories which are buying a new NC machine should attach this DSTV description to their order form and so protect themselves from any surprises.

## Generalities

This interface describes the link between the CAD and graphical system to the NC machine of the workshop. It contains only the data of the pieces independently of the NC machine. The data of the parts are divided in :

- Header Data
- Description of the holes
- Description of internal and external contours with welding preparation
- Description of numerotation
- Description of the marks by powder or by punch
- Description of special cuts
- Description of bended parts

It is the distributor of the machine who must guaranty that its Postprocessor can transform the piece's data from this interface to a correct and collisions free machine program. The advantage of this interface is that the data introduced before the fabrication will not be affected if the workshop needs to use another machine. These changes in the workshop can be done without any changes in the piece data.

## Interface file

The interface file is an editable text-file (ASCII-File). This file is created in the CAD computer and sorted by order, it can be transferred by any transfer procedure (KERMIT, DPCI, EMT for example) to the computer of the NC machine or directly in this one.

Each part has its own file. The name of the file is composed by the Name followed by an extension. For the extension, of maximum 3 characters, we recommend **NC**. The Name must be meaningful and contains the number of the Drawing and the Piece. So for example the file **Z23P15.NC** contains the data of the Piece 15 of the Drawing 23. Of course, you must control that the length of the Name is compatible with the Operating System used.

The syntax depends on the different possible descriptions which are described hereafter. The first two columns have a special meaning. They contain a **Code Bloc** giving the beginning of a part, the opening of a bloc or a comment line. The line with the **Code Bloc** is empty from the third column, the data lines start with two space. From the third column the format is free. The separator of the data is the space.

For compatibility reasons, the passage of a numerical value to a letter or vice-versa is also interpreted as a separator. (This is the reason why the numerical value must be separated either by at least one space, or by a letter which must be interpreted.)

Code bloc	Signification
<b>ST</b>	<b>ST</b> art = <b>beginning</b> of piece description
<b>EN</b>	<b>EN</b> d = <b>end</b> of piece description
<b>BO</b>	Opening bloc <b>hole</b>
<b>SI</b>	Opening bloc <b>numbering</b>
<b>AK</b>	Opening bloc <b>external contour</b>
<b>IK</b>	Opening bloc <b>internal contour</b>
<b>PU</b>	Opening bloc <b>powder</b>
<b>KO</b>	Opening bloc <b>mark</b>
<b>SC</b>	Opening bloc <b>cut</b> (Saw, Cutting)
<b>TO</b>	Opening bloc <b>Tolerance</b>
<b>UE</b>	Opening bloc <b>Camber</b>
<b>PR</b>	Opening bloc <b>Profile</b> description
<b>KA</b>	Opening bloc <b>Bending</b>
<b>En (0 &gt;= n &lt;= 9)</b>	Opening bloc definition <b>Plan n</b>
<b>Bn (0 &gt;= n &lt;= 9)</b>	Opening bloc <b>BO</b> of Plan <b>n</b>
<b>Sn (0 &gt;= n &lt;= 9)</b>	Opening bloc <b>SI</b> of Plan <b>n</b>
<b>An (0 &gt;= n &lt;= 9)</b>	Opening bloc <b>AK</b> of Plan <b>n</b>
<b>In (0 &gt;= n &lt;= 9)</b>	Opening bloc <b>IK</b> of Plan <b>n</b>
<b>Pn (0 &gt;= n &lt;= 9)</b>	Opening bloc <b>PU</b> of Plan <b>n</b>
<b>Kn (0 &gt;= n &lt;= 9)</b>	Opening bloc <b>KO</b> of Plan <b>n</b>
<b>**</b>	Comment Line Can be in any place of the interface These informations are also saved: it means that they cannot be lost with further uses.

## Units

The interface contains free text, integer numbers (without unity), lengths, angles, weight and painting surfaces by meter.

Value	Unity	Format
Free Text	-	\$ a (cadré à gauche, max. 80 Caract.)
Integer number	-	i
Length	[mm]	f (decimal number)
Angle	degree	f
Weight by meter	[kg/m]	f
Painting surface by meter	[m <sup>2</sup> /m]	f
Empty column	-	x

The angles are positive in the mathematical orientation (anti-clock-wise).

## Used Profiles

The interface is previewed for the current steel structure profiles. Considering the quantity of the different designations for different profiles, we will use a **Code Profile** to recognize them more easily.

The names and designations of the profiles are taken in the standard of DSTV called : „**Einheitliche Bezeichnungen für den Datenaustausch im Stahlbau**“.

Code Profile	Type of Profile
I	Profile <b>I</b>
L	Profile <b>L</b>
U	Profile <b>U</b>
B	Sheets, <b>Plate</b> , teared sheets, etc.
RU	<b>Round</b>
RO	<b>Rounded Tube</b>
M	<b>Rectangular Tube</b>
C	Profile <b>C</b>
T	Profile <b>T</b>
SO	<b>Special</b> Profile

The **Code profile** identifies the type of the profile.

## The coordinates system of the piece

The different faces of a piece depend of the positions of the piece in the machine and are positioned in the coordinates system of these reference planes of the machine. The name of these reference planes and the position of the coordinates sytem by type of profile are represented in the scheme below.

Prof-type			
<b>I</b>		<b>RO</b> <b>RU</b>	
<b>U</b>		<b>B</b>	
<b>L</b>		<b>C</b>	
<b>M</b>		<b>T</b>	

V = Web=front face U = Bottom O = Top H = Behind  
Np = Zero Point T = Displacement Direction

All the coordinates are referenced to this coordinates system with theoretical dimensions of perfect profiles perfectly laminated. The smallest X-coordinate of a piece is 0.0, the plates are described by the smallest rectangle in which they can be inserted.

## System of Coordinates of the Standard Views

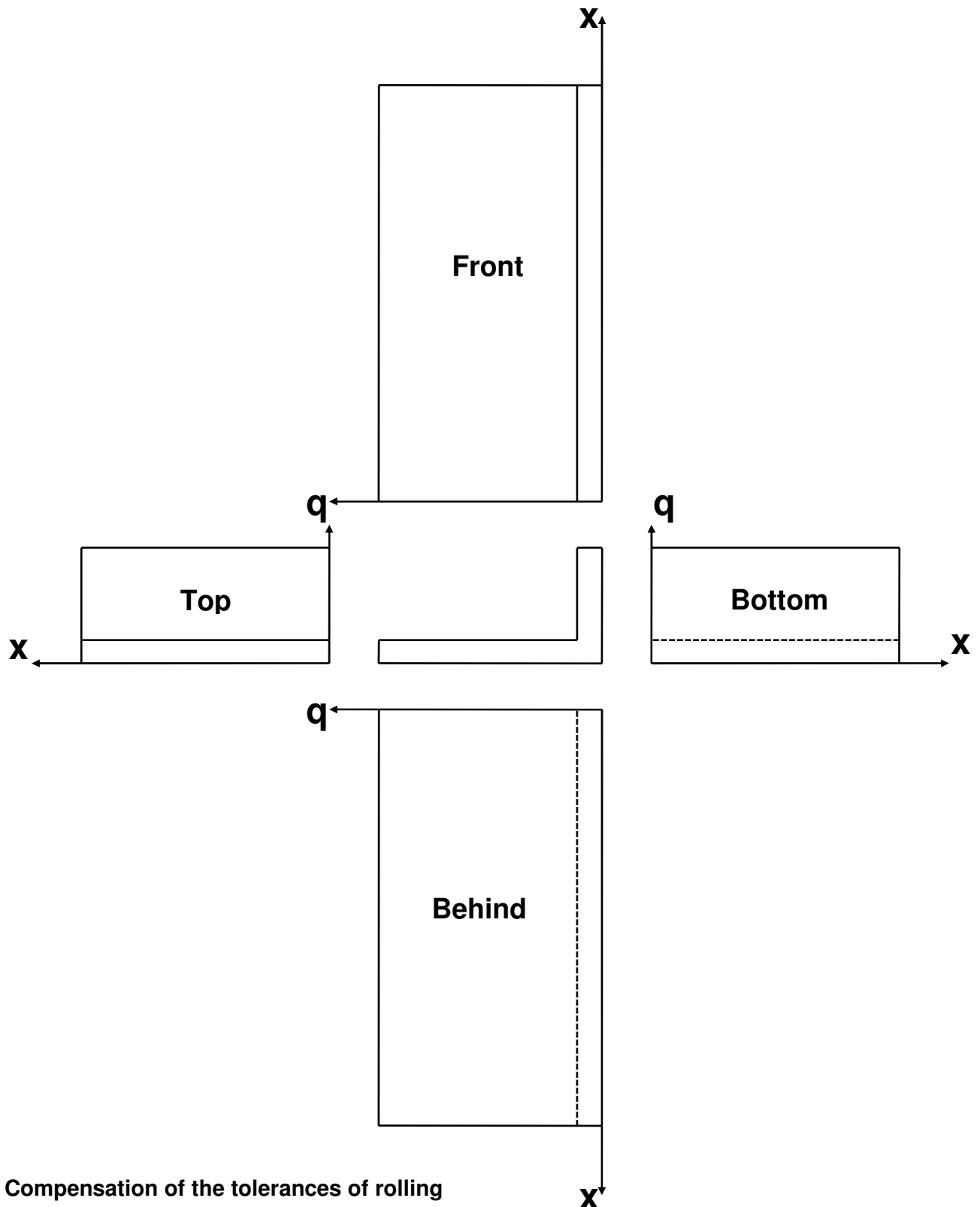

### Compensation of the tolerances of rolling

The reference of the dimension (for example „upper edge“) indicates from which edge of the piece the dimensions are taken. That means that the eventual tolerances of rolling will be placed on the opposite. If we give no reference for the dimension, the previous value stays valid. The reference of the dimension does not modify the value of a coordinate, it is the post-processor which must use it to balance the tolerance of rolling.

### Header data



The header data follow immediately the Code Bloc **ST** for the beginning of the description of the piece. They contain the most important data of the piece and the geometrical dimensions which are necessary for the NC.

Format	Signification	For the sheets
2x, a	Order identification	
2x, a	Drawing identification	
2x, a	Phase identification	
2x, a	Piece identification	
2x, a	Steel quality	
2x, i	Quantity of pieces	
2x, a	Profile	
2x, a	Code Profile	
2x, f [ , f ]	Length , Saw Length < mm >	
2x, f	Profile height < mm >	Width
2x, f	Flange width < mm >	0.0
2x, f	Flange thickness < mm >	0.0
2x, f	Web thickness < mm >	Sheet thickness
2x, f	Radius < mm >	
2x, f	Weight by meter < kg/m >	kg/m <sup>2</sup>
2x, f	Painting surface by meter < m <sup>2</sup> /m >	m <sup>2</sup> /m <sup>2</sup>
2x, f	Web Start Cut < degree >	
2x, f	Web End Cut < degree >	
2x, f	Flange Start Cut < degree >	
2x, f	Flange End Cut < degree >	
2x,a	Text info on piece	
2x,a	Text info on piece	
2x,a	Text info on piece	
2x,a	Text info on piece	

**The skew cuts angles must be given in any case**

After this bloc containing the header data, follow, in any order, the blocs giving the form. We recognize them with the Code in the columns 1 and 2.

If the program cannot read a bloc, it must skip to the line where it can find a readable bloc.

### Saw length

If an Rough length is necessary for the workshop, this one is introduced behind the normal length as Saw length. The saw length is the length between the teorical points. We will always take the shortest one.

Length data in the Bloc **ST** : Length , Saw Length.

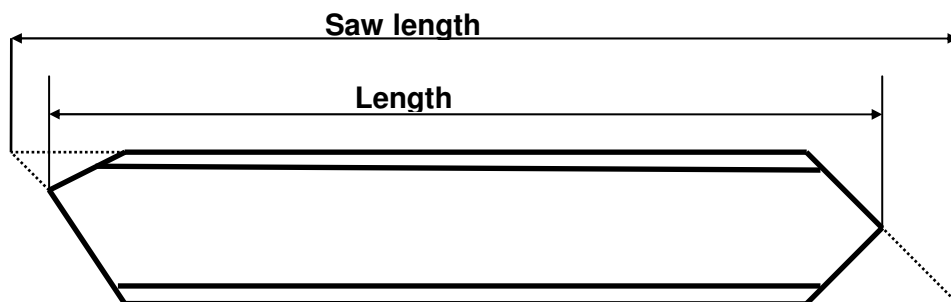

### Skew Cuts

The skew cuts of the web are represented in the view of the front face, the ones of the flange in the bottom face.

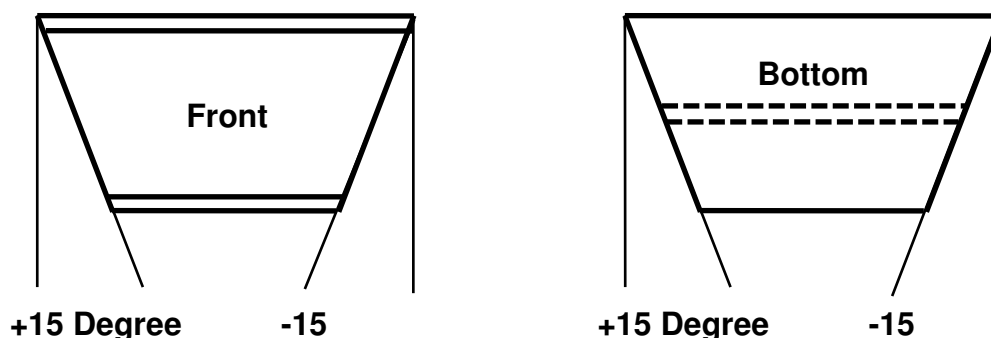

## Bloc List of Holes

The Bloc List of holes starts by **BO** in column 1 and 2.

The data relative to a hole are composed by the reference plane of the piece in which the hole has to be done, the absolute coordinates in X and Y, the diameter, one Code for the fabrication and if necessary the data for slotted or rectangular holes.

For the countersink or threaded holes some more data are necessary. It is the post-processor which is doing the repartition for the steps for the pre-drilling and the thread. To describe the slotted or rectangular holes we add the value ttt.tt the letter "l" the width, height and the angle.

### Format:

**2xa1f      a1f      a1 f      1x f      a1 f      1x f      1x f**

o	o	g	l
..v xxxxxx.xx	qqqqqq.qq	ddd.dd ttt.tt	bbbb.bb hhhh.hh ww.ww
u	s	m	
h	u	s	l => slotted hole, rectangul. hole Values : Width, Height, Angle
			=> Complete hole. d= diameter, t= 0.0
			g => Thread. d= diameter, t= 0.0
			l => Left threaded, d= diameter, t= 0.0
			m => Mark, Trace. d= 0.0, t= 0.0
			s => Counter d= Diameter t=depth countersink
			o => Dimensions reference top edge
			=> Previous Dimensions reference
			s => Dimensions reference axis
			u => Dimensions reference bottom edge
			o => top flange
			v => front web
			u => bottom flange
			h => behind web

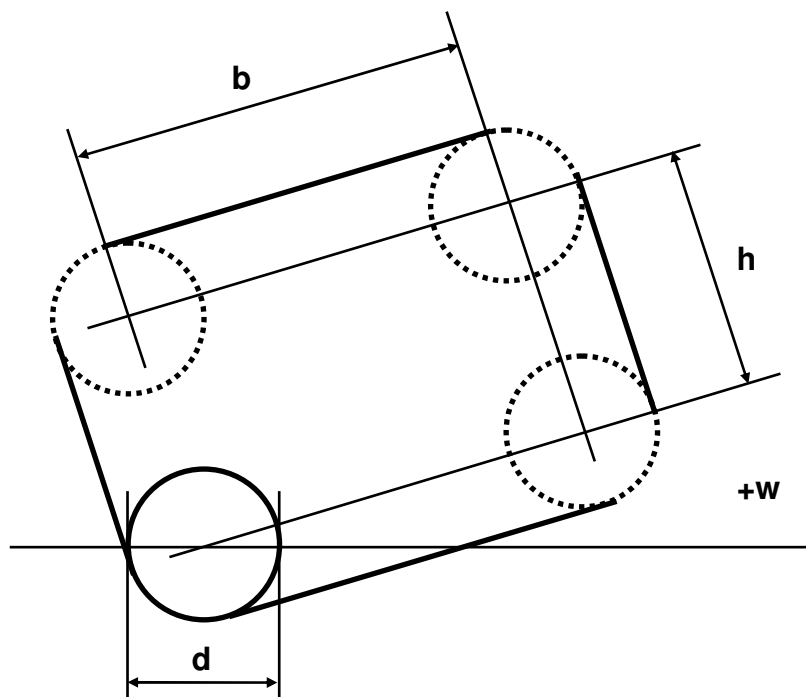

**Complete holes, Not complete holes and Countersink holes**

The dimensions, etc. for the countersink bolts follow the DIN 74 Part 1 and Part 2, the complete holes the DIN ISO 273 and the diameter for the pre-drilling for the threaded holes the DIN 336. The different forms of holes are represented in the four examples here after:

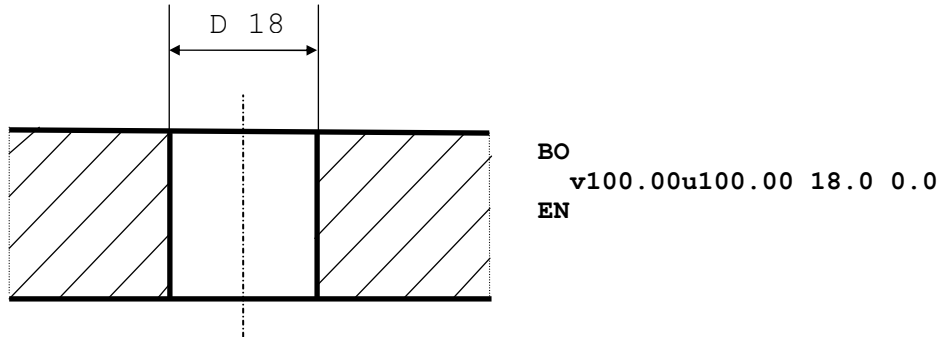

```
BO
v100.00u100.00 18.0 0.0
EN
```

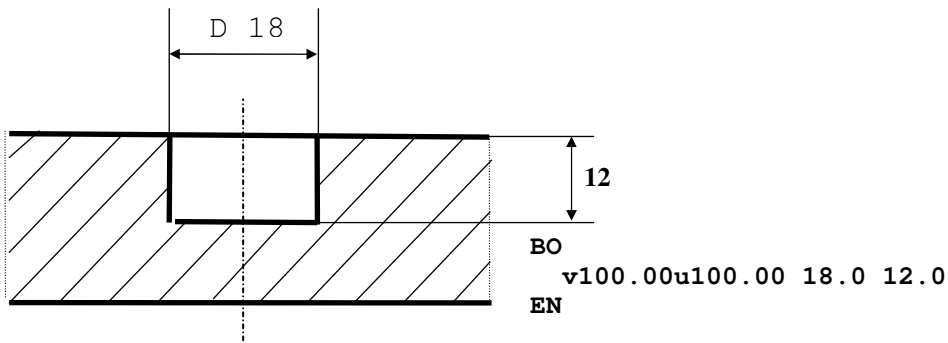

```
BO
v100.00u100.00 18.0 12.0
EN
```

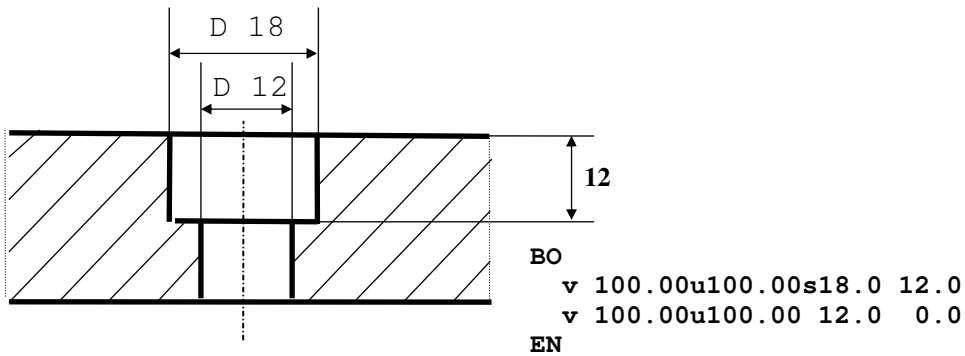

```
BO
v 100.00u100.00s18.0 12.0
v 100.00u100.00 12.0 0.0
EN
```

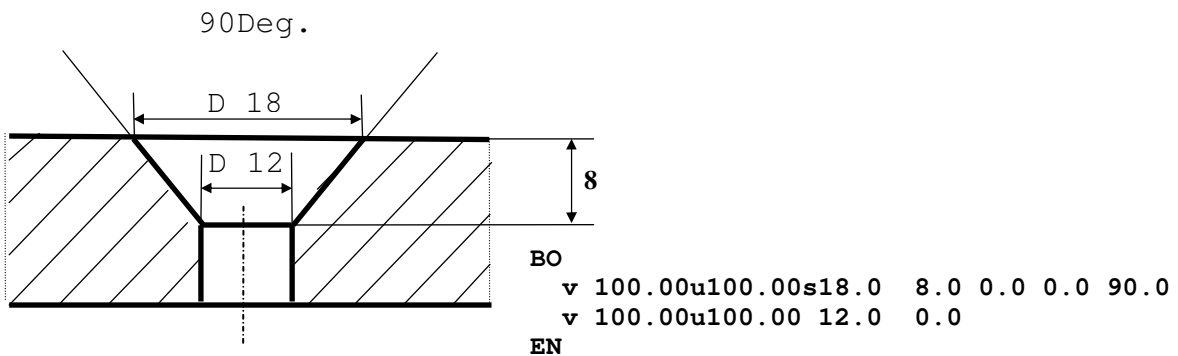

```
BO
v 100.00u100.00s18.0 8.0 0.0 0.0 90.0
v 100.00u100.00 12.0 0.0
EN
```

## Bloc Marks by Powder or by Punch

The Bloc Marks by Powder or by Punch for the flame cutting begin by the Code Bloc **PU** for the powder and **KO** for the punch in column 1 or 2.

The description is identical to the internal contour one.

### Format:

**2xa1 f            a1 f            1x f**

---

```

o          o
..v xxxxxx.xx  qqqqqq.qq rrr.rr
u          s
h          u          Radius

```

o => Dimensions reference top edge  
=> Previous Dimensions reference  
s => Dimensions reference axis  
u => Dimensions

o => top flange  
v => front web  
u => bottom flange  
h => behind web

From the second point of a same contour, it is no more necessary to indicate to which face the contour belongs.

## Bloc Numeration

The Bloc Numeration starts by the Code **SI** in column 1 and 2.

The data for a numbering are composed by the reference plane of the piece in which the numbering will be done, the absolute coordinates in X and Y, an angle, the text height and the text to write itself.

### Format:

**2xa1f            a1 f            1x f    1x i    a1 40a1**

---

```

o          o          r
..v xxxx.xx  qqqq.qq ww.ww hhh  a.....a
u          s          z
h          u

```

r => The Text follow the piece if turned  
empty => Text at the same position  
z => Force all parameters  
If one or more parameters are not done  
The numeration is not done.

Text Height (mm)

Angle

o => Dimensions reference top edge  
=> Previous Dimensions reference  
s => Dimensions reference axis  
u => Dimensions

o => top flange  
v => front web  
u => bottom flange  
h => behind web

## Bloc external & internal Contour

The Bloc Contour starts by **AK** or **IK** in the column 1 and 2.

The Bloc External Contour must not be introduced, if the piece is completely described by its length, its dimensions and its skewed cuts in the header data or if the Bloc Cut has been completely and correctly described.

The description of the contour is based on the introduction of Points and parallelly introduction of radius. The sign + in front of the Radius gives the orientation of this one: the sign + is the mathematical orientation. The maximal angle is +/- 180°. We must divide an angle of 220° in 2 angles : 180° and 40°

All contours have to be closed, it means that the coordinates X and Y of the first and the last point of the contour are identical. All others points of the contour cannot be described two times. The external contours are described in the mathematic orientation and the internal contours clockwise.

For the profiles, the description of the contour is done by a transformation of the profile in plates. The dimensions of the plates is the total height of the profile, for example the web of a beam HEB has a height equal to the width of the web plus the thickness of the two flanges.

A „Plate“ defined like this is easily identified by the letters "o, u, v, h" each letter gives the right reference plane of the beam. Each "Plate" is one face of the beam, it is in real dimensions, and no other material can be in interference with it. You can use all the faces but it is better to use first the faces "o et v". If for a profile, by following the rules here-before, we have several outside contours(in the same view), they will be merged in a unique one. Thus a Rectangular Tube(M) and a C Profile(C) will only have a "PLATE" to describe their web contour.

### Format:

2xa1f	a1 f	a1 f	1x f	1x f	1x f	1x f
o	o	t				
..v xxxxxx.xx	qqqqqq.qq	rrr.rr	www.ww	yyy.yy	www.ww	yyy.yy
u	s	w	Value for the welding preparation			
h	u		Radius			
			t or w : Tool for the notche			
			o => Dimensions reference top edge			
			=> Previous Dimensions reference			
			s => Dimensions reference axis			
			u => Dimensions			
			o => top flange			
			v => front web			
			u => bottom flange			
			h => behind web			

From the second point of a same contour, it is no more necessary to indicate to which face the contour belongs.

For the round tubes and the solid rounds, the „Plate“ will be the development of the external cylindrical surface of the profile. The width of the "plate" will be the external perimeter of the profile, it is described in „V“.

All the contours describe the external edge of the material. If we have also welding preparation they are oriented to the external edge of the contour described in the direction of the material. For the Profiles „divided“ in „Plates“ the special cuts in direction of the material can be specified by the welding preparation.

**Welding preparation (Forming of the edges)**

For all the "Plates" described by contour we can give the forming of the edges of the thickness of the plates by introducing the welding preparation.

Two values can be introduced after the radius of a point of the contour, they give for this point the angle of flamecutting ( $\Phi$ ) to the verticale and the distance Y see sketches.

We will use two couples of values if we need a welding preparation on both sides.  $\Phi$  can be positive or negative see sketches.

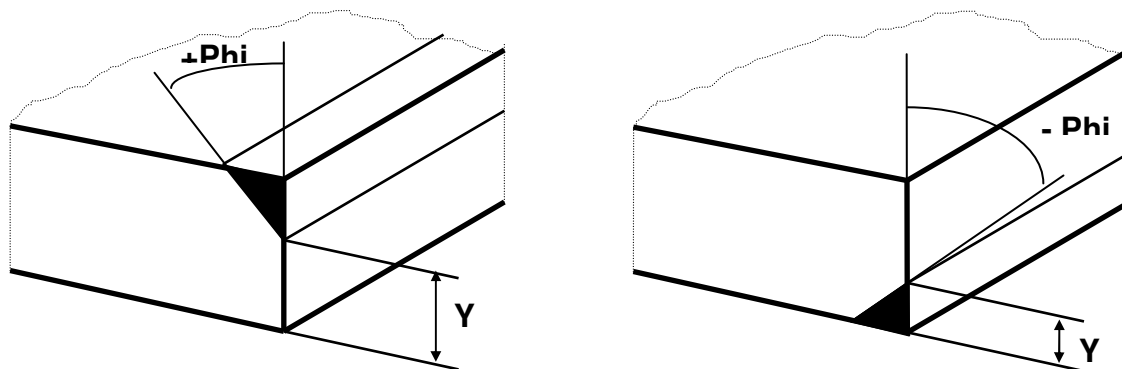

**Notches**

When notches are needed, the Bloc AK contains an information line which is not a part of the contour description.

This line contains the coordinates of the corner as well as the type of radius to notch this corner. We write "t" if we want a tangential notch or a "w" if we want a hole like hereafter.

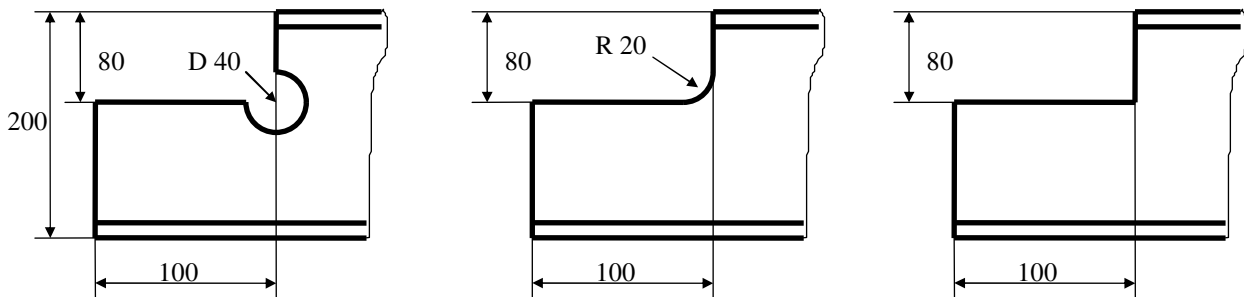

AK			
v	100.00u	200.00	0.00
	100.00	140.00	-20.00
→	100.00	120.00w	-20.00
	100.00	100.00	-20.00
	80.00	120.00	0.00
	0.00	120.00	0.00
	0.00	0.00	0.00

AK			
v	100.00u	200.00	0.00
	100.00	140.00	-20.00
→	100.00	120.00t	-20.00
	80.00	120.00	0.00
	0.00	120.00	0.00
	0.00	0.00	0.00

AK			
v	100.00u	200.00	0.00
	100.00	120.00	0.00
→	100.00	120.00w	0.00
	0.00	120.00	0.00
	0.00	0.00	0.00

### Bloc Cut (Saw, Cutting)

The Bloc Cut is opened by the Code Bloc **SC** in column 1 and 2. The cuts are always given by a normal vector to the initial or final section of the profile coming out from the material to outside. This normal vector starts from a specific point of the section.

#### Format:

**2x 1x f      1x f      1x f      1x f      1x f      1x f**

---

```
.. xxxxxx.xx yyyyyy.yy zzzzzz.zz xxxxxx.xx yyyyyy.yy zzzzzz.zz
```

### Bloc Tolerance

The Bloc Tolerance starts with the Code Bloc **TO** in column 1 and 2 and must be distribute proportionnaly on the length of the piece.

The Tolerance values for one length of beam are given by a minimum and a maximum value.

#### Format:

**2x f      1x f**

---

```
..xxxx.xx yyy.yy
```

### Bloc Camber ( Preform )

The Bloc Camber starts by the Code **UE** in the column 1 and 2.

All the coordinates of the interface are given for the beam **WITHOUT** camber.

#### Format:

**2xa1f      1x f**

---

```
o
..v xxxx.xx uuuu.uu
u
h
```

```
o => top flange
v => front web
u => bottom flange
h => behind web
```

## Bloc Plane Definition

We can use more **Planes** only for the Geometries, for which the reference Plane cannot be described by the standard faces of the pieces, given by the letters:

- **v** for Front,
- **o** for Top,
- **u** for Bottom and
- **h** for Behind

The Definition starts with the Code Bloc **E** in Column 1 and a Number between **0** and **9** in Column 2, which is the number of the **Plane**.

After we have 3 lines,

- the first contain the coordinates X-, Y- and Z- of the Original Point of the **Plane**,
- the second contain the coordinates of a point of the X- axis situated at 100mm from the Origin
- the third contain the coordinates of a point of the Y- axis situated at 100mm from the Origin.

As Origin of the **Plane** we take one of the 2 intersection Points of the **Plane** with the Y- Axis and the Z- Axis of the system of coordinates of the piece, the right point is the point which has the smaller distance with the zero-point of the piece.

**After** the definition of the **Plane** are written the affiliated geometries, in that the opening Code Bloc of the Bloc contains in column 2 the number of the **Plane** to which it is reported. The letter at the start of the lines of coordinates giving the face of the piece (for example. v for Front) is not existing if these lines are reported to a **Plane**.

To not reach the limit of 10 definitions of **Plane**, we can call several times the same number. Before the new call of a number of **Plane** the description of geometries which are reported to the old **Plane** must be finished.

The use of the Blocs **BO**, **IK** used for standard pieces, can also be done after the definition of additional **Plane**.



**Example of file with a call to an additional Plane E1:**

```

ST
**NC-DSTV-Schnittstelle, Stand Juli 1998
1
1
14
14
RST37-2
2
ZS175*1.5

```

```

SO
1133.00
175.00
81.00
1.50
1.50
4.00
4.416
0.753
0.000
0.000
0.000
0.000
Pfette

```

```

PR
+ 0.000 79.500 0.00
+ 48.000 79.500 0.00
+ 311.000 165.000 0.00
+ 347.000 165.000 0.00
+ 347.000 23.415 0.00
+ 310.400 2.259 0.00
+ 311.910 0.000 0.00
+ 350.000 21.650 0.00
+ 350.000 168.000 0.00
+ 310.510 168.000 0.00
+ 47.540 82.500 0.00
+ 3.000 82.500 0.00
+ 3.000 239.820 0.00
+ 39.620 260.950 0.00
+ 38.120 263.550 0.00
+ 0.000 241.550 0.00
+ 0.000 79.500 0.00

```

```

E1
0.00 0.00 90.00
100.00 0.00 90.00
0.00 151.00 41.00

```

```

B1
1100.00u 53.00 18.00
1100.00u 131.00 18.00

```

```

S1
100.00u 50.00 0000.00 5 1/1/14

```

```

EN

```

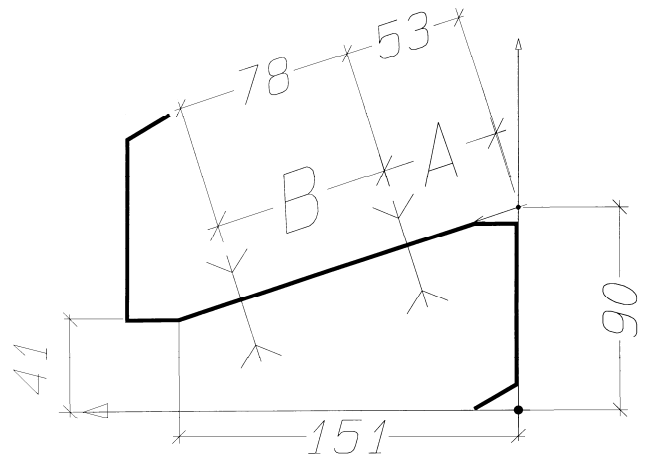
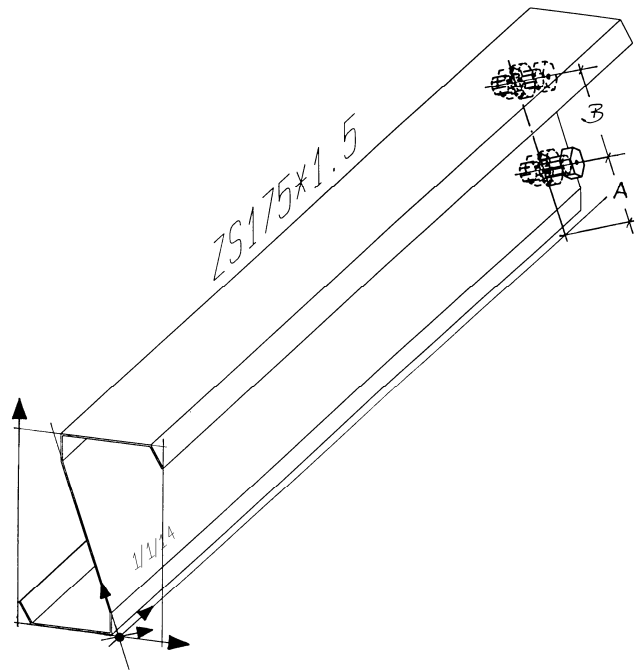

**Comment:**

For the description of Special Profiles the Section of the profile is defined by the **Bloc Profile**. With the introduction of the interfaces of the Steel Structure Products and the Standardization of the Material description, the preparation of a List of Special Profiles is discussed. This List will clarify the names of Profiles, their Section and their Position referred to the Coordinates System of the Piece. As soon as the used Profile will be in the List, we can forget to use the **Bloc Profile**.

### Bloc Bended Parts

The Bloc of the bended parts begins by **KA** in the columns 1 and 2.

After we have for every axis of bending a line with the coordinates of the two points giving the axis of bending, which is in the plane of the material, then the angle and the radius of bending. The coordinates of the bending are given like all other elements compared to the the piece not bended. The sign in front of the angles gives the direction of these angles. A positive angle describes a bending in the plane XY in Z positive direction.

**Format:**

**2x f          1x f          1x f          1x f**

..xxxxxx.xx      yyyyyy.yy      www.ww      rrr.rr

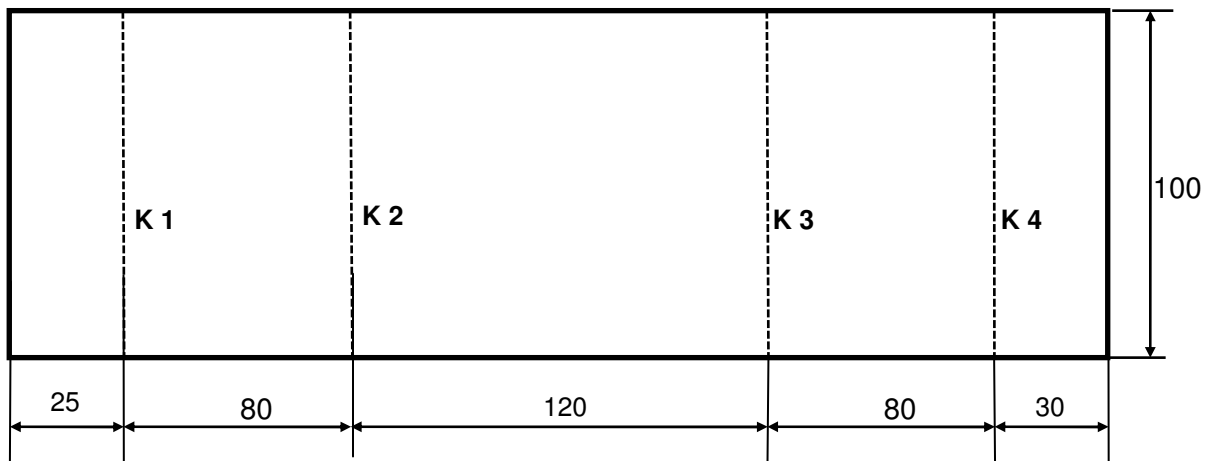
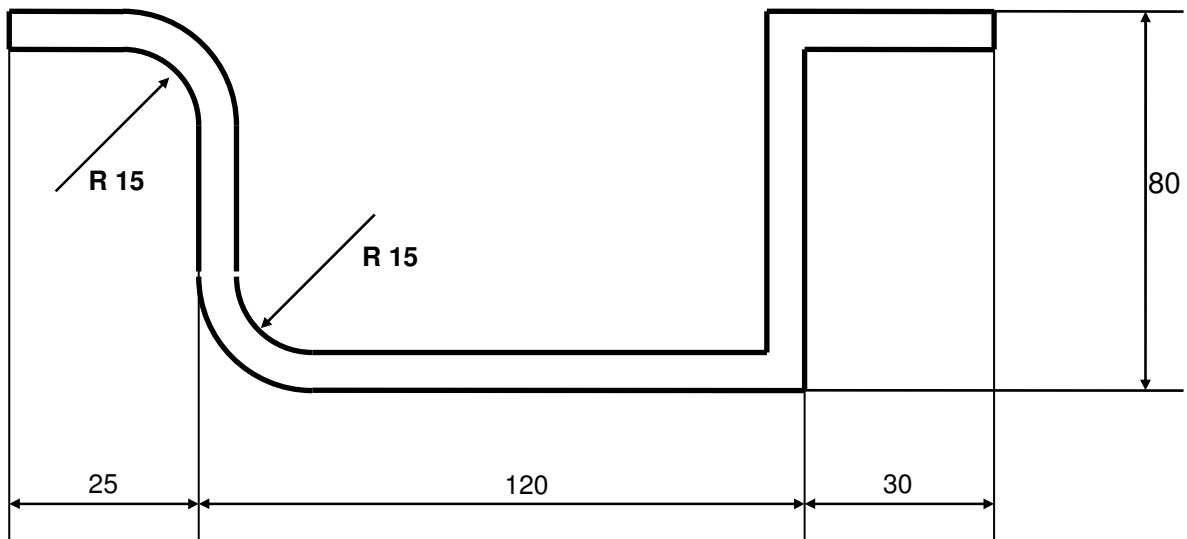
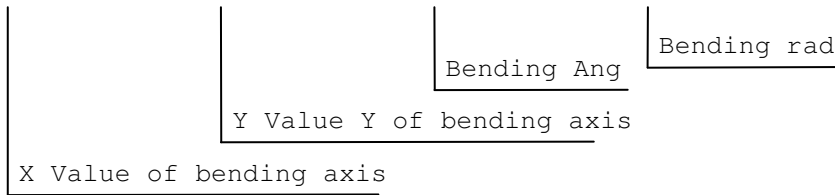

```
KA
25.0 0.0 25.0 100.0 -90.0 15.0
105.0 0.0 105.0 100.0 90.0 15.0
225.0 0.0 225.0 100.0 90.0
305.0 0.0 305.0 100.0 -90.0
```

## Bloc Profile (Own user profile sections)

The Bloc Profile begins by **PR** in the column 1 and 2.

The section of the profile can be described by the Code Bloc **PR**.

The description is done by the contour description. In place of the letters giving the face of the piece we give a sign '+' for the external contours, and a sign '-' for the internal contours of the sections. The description of the contour must follow a normal rotation without crossing. The description is possible only in one of the four faces.

The Code Profile must be **SO**.

### Format:

**2xa1f**            **1x f**            **1x f**

---

```

+
..- YYYYYY.YY   zzzzzz.zz   rrr.rr

```

Radius

+ => Code for external Contour  
- => Code for internal Contour

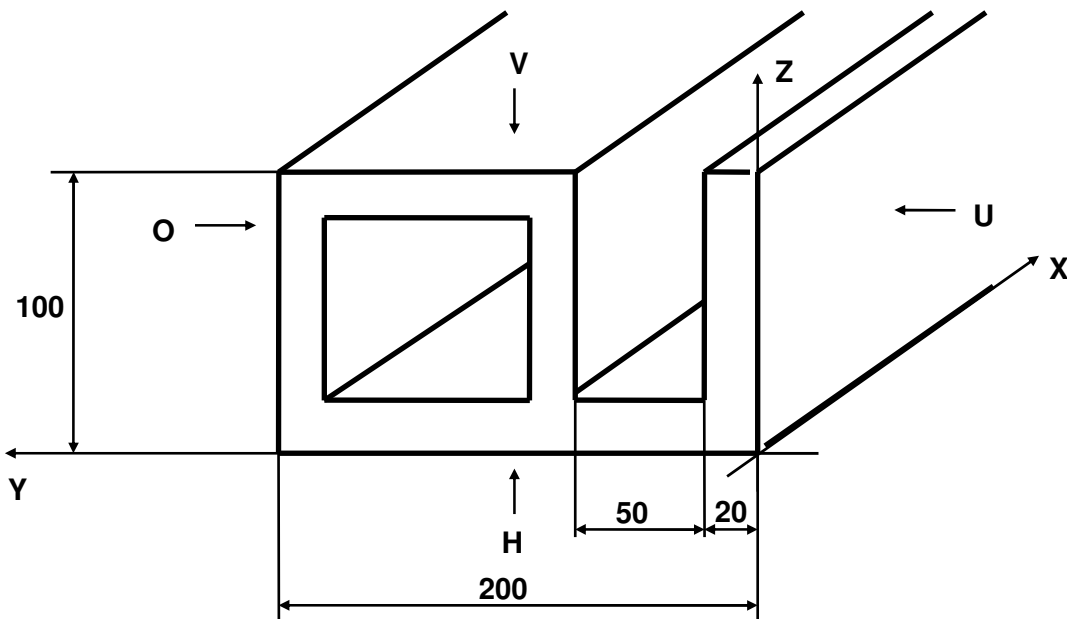

```

PR
+  0.0   0.0   0.0
+  0.0  100.0  0.0
+  20.0  100.0  0.0
+  20.0   20.0  0.0
+  70.0   20.0  0.0
+  70.0  100.0  0.0
+ 200.0  100.0  0.0
+ 200.0   0.0   0.0
+   0.0   0.0   0.0
-  90.0   20.0  0.0
- 180.0   20.0  0.0
- 180.0   80.0  0.0
-   90.0   80.0  0.0
-   90.0   20.0  0.0

```

## Bloc Informations

The Bloc Informations begins by **IN** in the columns 1 and 2.

The data for an information is composed by the description of the area, the separator column (:) and the contents of the area.

### Format:

**2xa a1 a**

---

```

..a...a : a.....a
|       | |
|       | | Contents
|       | |
|       | | Separator
|       | |
|       | | Description in german

```

### IN

BESTELLER	: Customer
OBJEKT	: Object
PROJEKTLEITER	: Project manager
STARTTERMIN	: Start date
ENDTERMIN	: End date
GRUNDANSTRICH	: First painting
DECKANSTRICH	: Final painting
ENTZUNDERUNG	: Blasting
VERZINKUNG	: Galvanized
GEZEICHNET VON	: Drawned by
GEZEICHNET AM	: Drawned on the
GERÜFT VON	: Controled by
GEPRÜFT AM	: Controled on the

ST

\*\*NC-DSTV-Schnittstelle

DSTV

1

3

3

RST37-2

1

HEB400

I

2000.00

400.00

300.00

24.00

13.50

27.00

155.000

1.930

0.000

0.000

0.000

0.000

TRAEGER

BO

v 1512.00o 144.00 24.00 0.001 100.00 60.00 10.00

v 450.00o 280.00 24.00

v 900.00o 300.00 29.00

AK

v 200.00o 0.00 0.00

v 1952.00o 0.00 0.00 -18.430 13.50

v 1952.00o 350.00 0.00

v 1750.00o 350.00 0.00

v 1750.00o 400.00 0.00

v 163.50o 400.00 0.00

v 150.00o 325.00 0.00

v 0.00o 325.00 0.00

v 0.00o 100.00 0.00

v 190.00o 100.00 -10.00

v 200.00o 100.00w -10.00

v 200.00o 110.00 -10.00

v 200.00o 90.00 0.00

v 200.00o 0.00 0.00

BO

u 1415.00s 251.50 24.00 0.001 70.00 0.00 0.00

u 350.00s 98.00 18.00

u 650.00s 229.00 20.00

u 1150.00s 240.50 22.00

AK

u 200.00s 0.00 0.00

u 1900.00s 0.00 0.00

u 2000.00s 300.00 0.00

u 200.00s 300.00 0.00

u 200.00s 0.00 0.00

BO

o 1415.00s 251.50 24.00 0.001 70.00 0.00 0.00

o 350.00s 98.00 18.00

o 650.00s 229.00 20.00

o 1150.00s 240.50 22.00

AK

o 159.50s 0.00 0.00 10.000 0.00

o 159.50s 300.00 0.00

o 1750.00s 300.00 0.00

o 1750.00s 0.00 0.00

o 159.50s 0.00 0.00

SI

u 200.00u 225.00 0000.00 5 1/1/1

