

Project

Item #

Quantity



GLOBE FOOD EQUIPMENT COMPANY

10 Quart Mixer

SP10



SP10 10 Quart Mixer

Model

- SP10 - 10 Quart Mixer



Standard Features

- 1/3 HP custom built motor
- Three fixed speeds
- Gear driven, high torque transmission
- Heat-treated hardened steel alloy gears and shafts
- Permanently lubricated transmission
- Thermal overload protection
- Rigid cast iron body
- Stainless steel bowl guard with built in ingredient chute
- NSF approved enamel gray paint
- Front mounted controls
- 15 minute timer
- Industry standard #12 attachment hub
- Safety interlocked bowl guard and bowl lift
- Non-slip rubber feet
- 6 foot cord and ground plug

Standard Accessories

- 10 quart stainless steel bowl
- Flat beater (aluminum)
- Stainless steel wire whip
- Spiral dough hook (aluminum)

Optional Attachments/Accessories

- Vegetable slicer for #12 hub
- Shredder/grater for #12 hub
- Meat grinder for #12 hub
- Flat beater (stainless steel)
- Spiral dough hook (stainless steel)
- Mixer table with undershelf

Standard Warranty

- 2 years parts and one year labor

Approved By: _____

Date: _____



GLOBE FOOD EQUIPMENT COMPANY

www.globeslicers.com

2153 Dryden Rd
Dayton, OH 45439
Phone: 937-299-5493
Phone: 800-347-5423
Fax: 937-299-4147



10 Quart Mixer

SP10

Specifications

Motor: 1/3 HP, grease packed ball bearing, air cooled, 115/60/1, 8 amps. Thermal overload protection (automatic reset).

Finish: NSF approved enamel gray paint.

Capacity: 10 quart (9 liter) bowl.

Transmission: Fixed speed transmission is made of heat treated, hardened alloy, precision milled gears that operate the planetary action and provide high torque mixing power. The gears are packed in a long lasting grease, and all shafts are mounted in ball bearings.

Safety Interlocks: The bowl guard and bowl lift lever are interlocked. The mixer will automatically shut down when the guard is opened or the bowl is lowered.

Agitator Speeds (RPMs):

Low	104
Intermediate	194
High	353

Attachment Speeds (RPMs):

Low	59
Intermediate	110
High	201

Standard Equipment: Standard equipment includes a 10 quart #304 series stainless steel bowl, aluminum spiral dough hook, stainless steel wire whip, aluminum flat beater, stainless steel bowl guard with built in ingredient chute, 15 minute timer, and #12 attachment hub. A sturdy hand lever on the body column raises and lowers the bowl as well as locking in place at the top and bottom positions.

Cord: 6 ft. flexible three wire cord and ground plug.

Dimensions:

Foot Print = 14.6" x 15.7"
(37.1cm x 39.9cm)
Overall Length = 21.2" (53.8cm)
Overall Width = 16.1" (40.9cm)
Overall Height = 24.6" (62.5cm)

Shipping Information:

Freight Class: 85
Net Weight: 132 lbs. (60 kgs.)
Shipping Weight: 255 lbs. (115.4 kgs.)
Shipping Dimensions:
32"W x 40"D x 48"H
(81.3cm x 101.6cm x 106.7cm)
Cartons are affixed to a skid (pallet).
The weight and dimensions of this skid are included above and may vary from shipment to shipment.

Optional Accessories:

- XXBEAT-10SS** Stainless Steel Flat Beater
- XXHOOK-10SS** Stainless Steel Spiral Dough Hook

XTABLE Mixer Table with Undershef (stainless steel top with galvanized steel undershef and legs)
30"W x 24"D x 24"H
(76.2cm x 61cm x 61cm)

Optional Attachments:

XMCA-SS Meat Grinder Assembly (Polished stainless steel cylinder, worm, ring, and pan. Includes knife, 3/16" plate, stainless steel pan, and pusher.)

Chopper Plate Sizes Available:

- CP00-12** Stuffing Plate
- CP02-12** 1/16" (2mm)
- CP04-12** 5/32" (4mm)
- CP06-12** 1/4" (6mm)
- CP08-12** 5/16" (8mm)
- CP10-12** 3/8" (10mm)
- CP12-12** 1/2" (12mm)
- CP14-12** 9/16" (14mm)
- CP16-12** 5/8" (16mm)
- CP18-12** 11/16" (18mm)

XVSA 9" Vegetable Slicer Assembly (includes an adjustable slicer plate)

XVGA 9" Shredder/Grater Assembly (includes a plate holder and a 3/16" shredder plate)

Shredder Plate Sizes Available:

- XSP332** 3/32" (2.3mm)
- XSP316** 3/16" (4.7mm)
- XSP14** 1/4" (6.3mm)
- XSP516** 5/16" (7.9mm)
- XSP12** 1/2" (12.7mm)
- XGP** Grater Plate

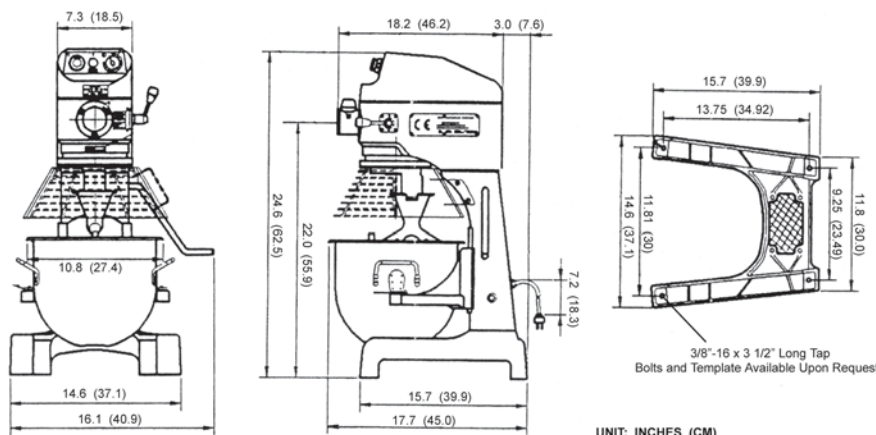

GLOBE FOOD EQUIPMENT COMPANY

www.globeslicers.com

2153 Dryden Rd
Dayton, OH 45439
Phone: 937-299-5493
Phone: 800-347-5423
Fax: 937-299-4147

Printed in U.S.A. 5-2006