

8 7 6 5 4 3 2 1

REVISIONS				
REV.	ZONE	DESCRIPTION	DATE	BY

FULL CABINET BED ASSEMBLY WITH UPPER CABINET



OPENED

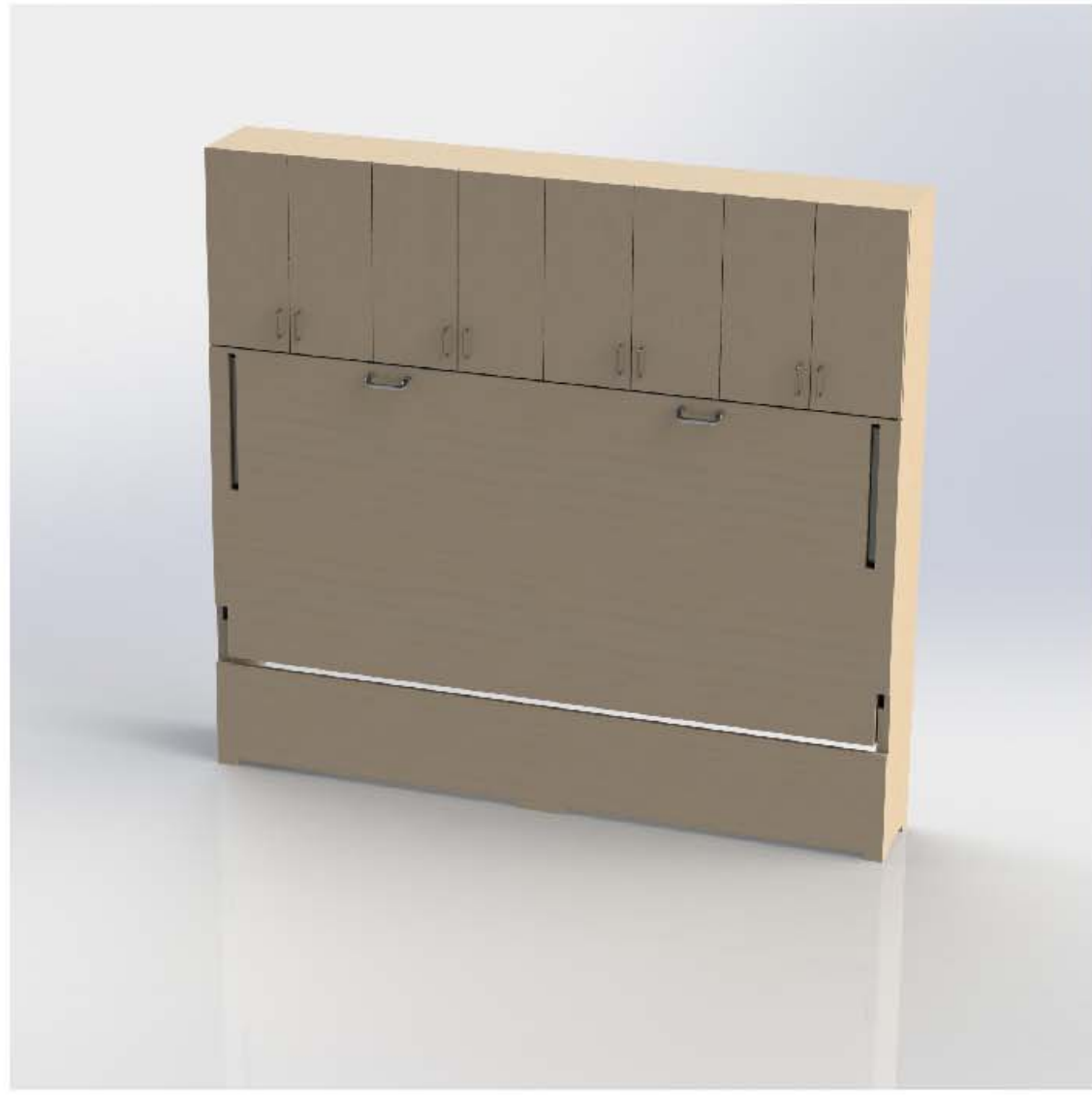

CLOSED

D
C
B
A

D
C
B
A

<p>UNLESS OTHERWISE SPECIFIED: DIMENSIONS ARE IN INCHES AND INCLUDE THICKNESS OF PLATING TOLERANCES:</p> <table border="1"> <thead> <tr> <th>BASIC DIMENSIONS</th> <th>2 PLACE DECIMALS</th> <th>3 PLACE DECIMALS</th> </tr> </thead> <tbody> <tr> <td>UP TO 6</td> <td>±.02</td> <td>±.005</td> </tr> <tr> <td>6 TO 24</td> <td>±.03</td> <td>±.010</td> </tr> <tr> <td>ABOVE 24</td> <td>±.06</td> <td>±.015</td> </tr> </tbody> </table> <p>ANGULAR DIMENSIONS ± 0.5° MATERIAL: FINISH:</p>	BASIC DIMENSIONS	2 PLACE DECIMALS	3 PLACE DECIMALS	UP TO 6	±.02	±.005	6 TO 24	±.03	±.010	ABOVE 24	±.06	±.015	<table border="1"> <thead> <tr> <th>NAME</th> <th>DATE</th> </tr> </thead> <tbody> <tr> <td>DESIGN BY</td> <td></td> </tr> <tr> <td>DRAWN BY</td> <td>DBC 05/03/14</td> </tr> <tr> <td>CHECKED BY</td> <td></td> </tr> <tr> <td>APPROVED BY</td> <td></td> </tr> </tbody> </table>	NAME	DATE	DESIGN BY		DRAWN BY	DBC 05/03/14	CHECKED BY		APPROVED BY		<p>TextualCreations MORE THAN JUST WORDS ON PAPER</p>
	BASIC DIMENSIONS	2 PLACE DECIMALS	3 PLACE DECIMALS																					
	UP TO 6	±.02	±.005																					
	6 TO 24	±.03	±.010																					
ABOVE 24	±.06	±.015																						
NAME	DATE																							
DESIGN BY																								
DRAWN BY	DBC 05/03/14																							
CHECKED BY																								
APPROVED BY																								
<p>PROPRIETARY AND CONFIDENTIAL</p> <p>THE INFORMATION CONTAINED IN THIS DRAWING IS THE PROPERTY OF DONALD B. CHEKE, SOLE PROPRIETOR OF TEXTUAL CREATIONS. COPYRIGHT 2014.</p> <p>ANY REPRODUCTION IN PART OR AS A WHOLE WITHOUT THE WRITTEN PERMISSION OF TEXTUAL CREATIONS IS PROHIBITED.</p>	<p>TITLE: FULL CABINET BED ASSEMBLY WITH UPPER CABINET</p>																							
		<table border="1"> <tr> <th>SIZE</th> <th>DWG. NO.</th> <th>REV</th> </tr> <tr> <td>B</td> <td></td> <td></td> </tr> </table>	SIZE	DWG. NO.	REV	B																		
SIZE	DWG. NO.	REV																						
B																								
		<table border="1"> <tr> <th>SCALE: 1:12</th> <th>WG:</th> <th>SHEET 1 OF 32</th> </tr> <tr> <td></td> <td></td> <td></td> </tr> </table>	SCALE: 1:12	WG:	SHEET 1 OF 32																			
SCALE: 1:12	WG:	SHEET 1 OF 32																						

8 7 6 5 4 3 2 1

8 7 6 5 4 3 2 1

REVISIONS				
REV.	ZONE	DESCRIPTION	DATE	BY

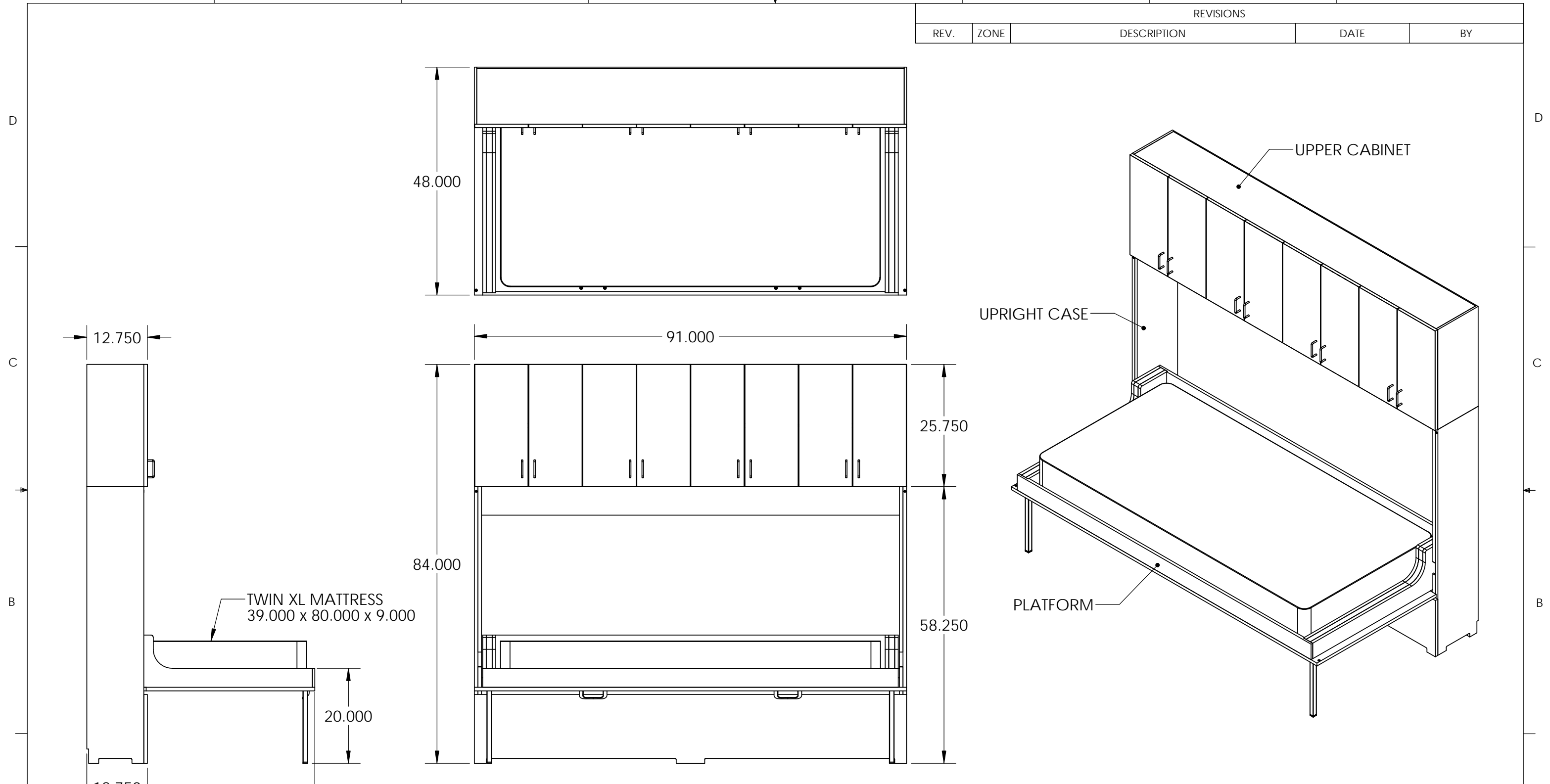

<p>UNLESS OTHERWISE SPECIFIED: DIMENSIONS ARE IN INCHES AND INCLUDE THICKNESS OF PLATING TOLERANCES:</p> <p>TOLERANCES ON:</p> <table border="1"> <thead> <tr> <th>BASIC DIMENSIONS</th> <th>2 PLACE DECIMALS</th> <th>3 PLACE DECIMALS</th> </tr> </thead> <tbody> <tr> <td>UP TO 6</td> <td>±.02</td> <td>±.005</td> </tr> <tr> <td>6 TO 24</td> <td>±.03</td> <td>±.010</td> </tr> <tr> <td>ABOVE 24</td> <td>±.06</td> <td>±.015</td> </tr> </tbody> </table> <p>ANGULAR DIMENSIONS ± 0.5°</p> <p>MATERIAL:</p> <p>FINISH:</p>	BASIC DIMENSIONS	2 PLACE DECIMALS	3 PLACE DECIMALS	UP TO 6	±.02	±.005	6 TO 24	±.03	±.010	ABOVE 24	±.06	±.015	<p>DESIGN BY</p> <p>DRAWN BY DBC</p> <p>CHECKED BY</p> <p>APPROVED BY</p>	<p>NAME</p> <p>DATE</p>	<p>TextualCreations MORE THAN JUST WORDS ON PAPER</p> <p>TITLE: FULL CABINET BED ASSEMBLY WITH UPPER CABINET</p> <table border="1"> <tr> <td>SIZE</td> <td>DWG. NO.</td> <td>REV</td> </tr> <tr> <td>B</td> <td> </td> <td> </td> </tr> </table> <p>SCALE: 1:20 WG: SHEET 2 OF 32</p>	SIZE	DWG. NO.	REV	B		
	BASIC DIMENSIONS	2 PLACE DECIMALS	3 PLACE DECIMALS																		
	UP TO 6	±.02	±.005																		
	6 TO 24	±.03	±.010																		
ABOVE 24	±.06	±.015																			
SIZE	DWG. NO.	REV																			
B																					
<p>THE INFORMATION CONTAINED IN THIS DRAWING IS THE PROPERTY OF DONALD B. CHEKE, SOLE PROPRIETOR OF TEXTUAL CREATIONS. COPYRIGHT 2014.</p> <p>ANY REPRODUCTION IN PART OR AS A WHOLE WITHOUT THE WRITTEN PERMISSION OF TEXTUAL CREATIONS IS PROHIBITED.</p>	<p>PROPRIETARY AND CONFIDENTIAL</p>	<p> </p>																			
<p> </p>	<p> </p>	<p> </p>																			
<p> </p>	<p> </p>	<p> </p>																			

8 7 6 5 4 3 2 1

REVISIONS				
REV.	ZONE	DESCRIPTION	DATE	BY

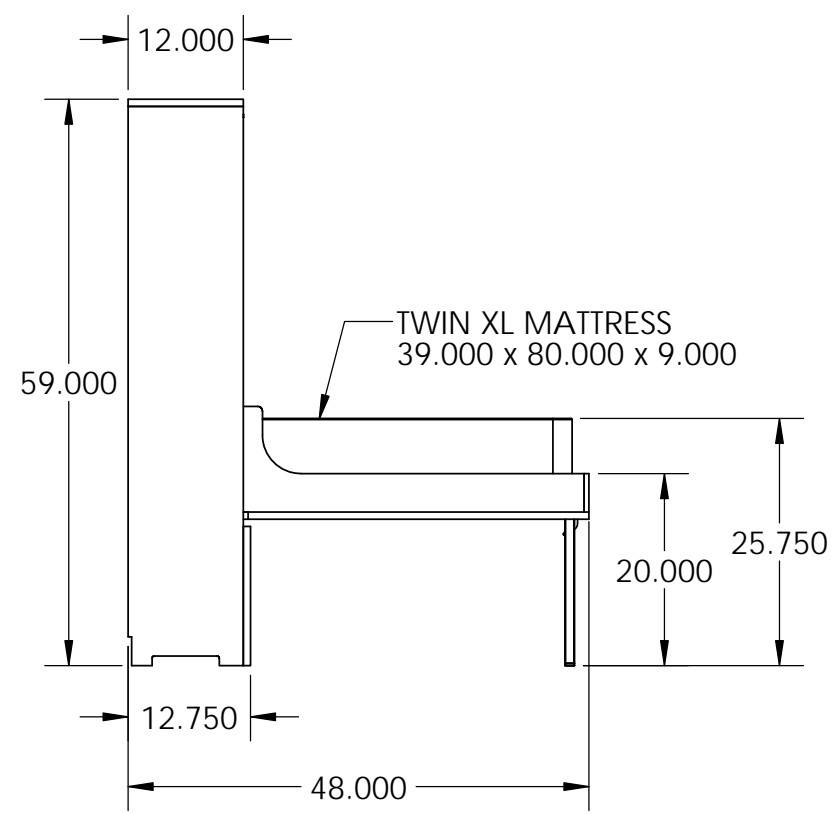
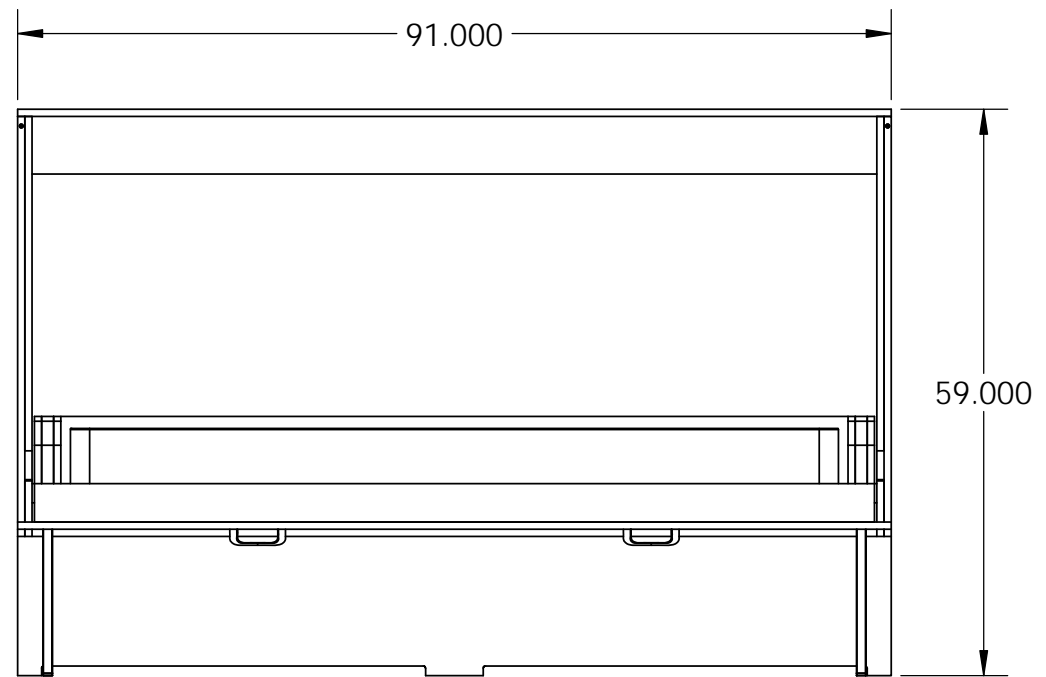
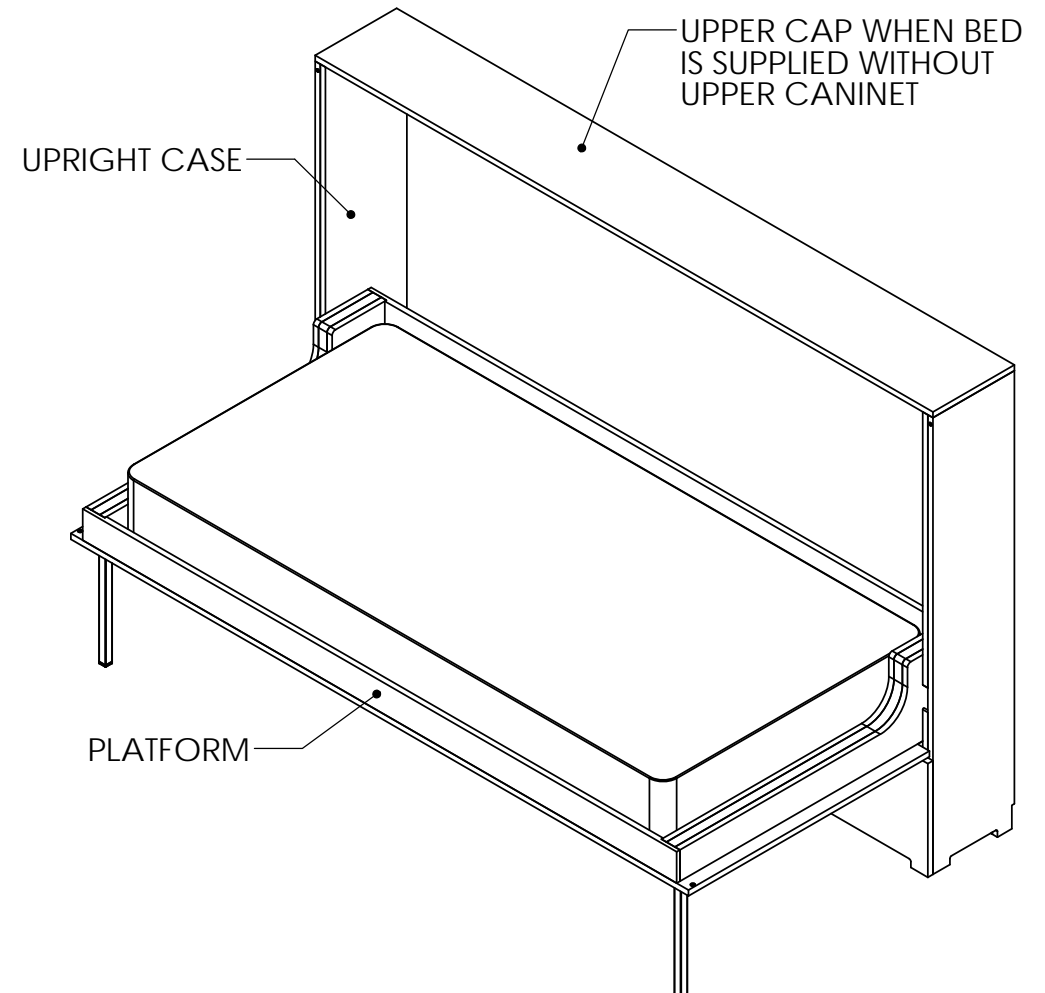
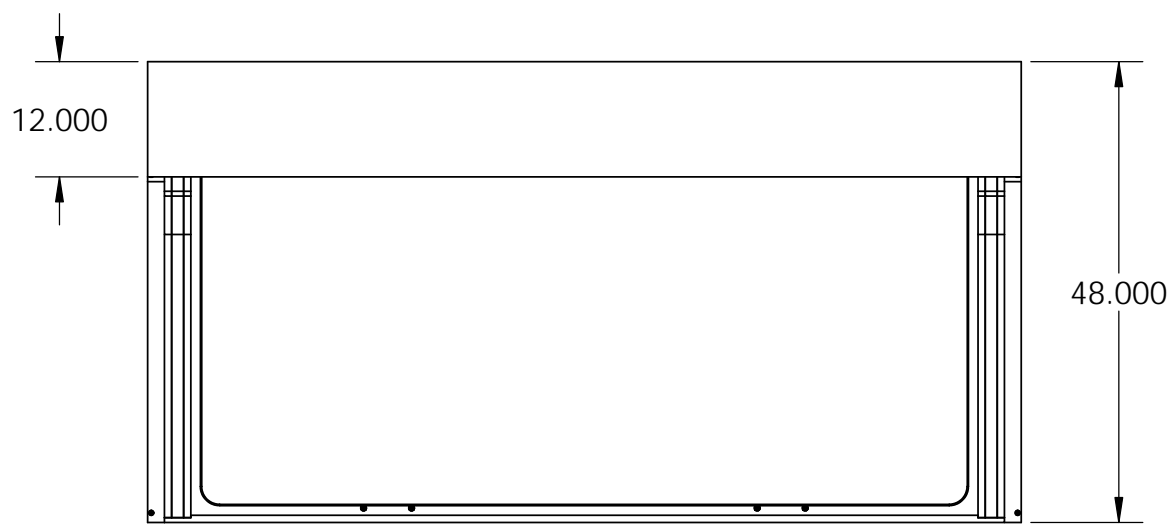

UNLESS OTHERWISE SPECIFIED:
DIMENSIONS ARE IN INCHES
AND INCLUDE THICKNESS OF PLATING
TOLERANCES:

TOLERANCES ON:		
BASIC DIMENSIONS	2 PLACE DECIMALS	3 PLACE DECIMALS
UP TO 6	±.02	±.005
6 TO 24	±.03	±.010
ABOVE 24	±.06	±.015

ANGULAR DIMENSIONS ± 0.5°
MATERIAL:
FINISH:

	NAME	DATE
DESIGN BY		
DRAWN BY	DBC	05/03/14
CHECKED BY		
APPROVED BY		

PROPRIETARY AND CONFIDENTIAL
THE INFORMATION CONTAINED IN THIS DRAWING IS THE PROPERTY OF DONALD B. CHEKE, SOLE PROPRIETOR OF TEXTUAL CREATIONS. COPYRIGHT 2014.
ANY REPRODUCTION IN PART OR AS A WHOLE WITHOUT THE WRITTEN PERMISSION OF TEXTUAL CREATIONS IS PROHIBITED.

TextualCreations
MORE THAN JUST WORDS ON PAPER

TITLE:
FULL CABINET BED ASSEMBLY WITHOUT UPPER CABINET

SIZE B	DWG. NO.	REV
SCALE: 1:20	WG:	SHEET 3 OF 32

ITEM NO.	PART NUMBER	QTY.
1	Upright Case Outside Panel	1
2	Upright Case Outside Panel Hinge Hold	1
3	MirrorUpright Case Outside Panel	1
4	MirrorUpright Case Outside Panel Hinge Hold	1
5	Upright Case Back Fasten Panel	2
6	Upright Case Lower Front Panel	1
7	Upright Horizontal Cap	1

REVISIONS				
REV.	ZONE	DESCRIPTION	DATE	BY

7 UPPER CAP WHEN BED IS SUPPLIED WITHOUT UPPER CANINET

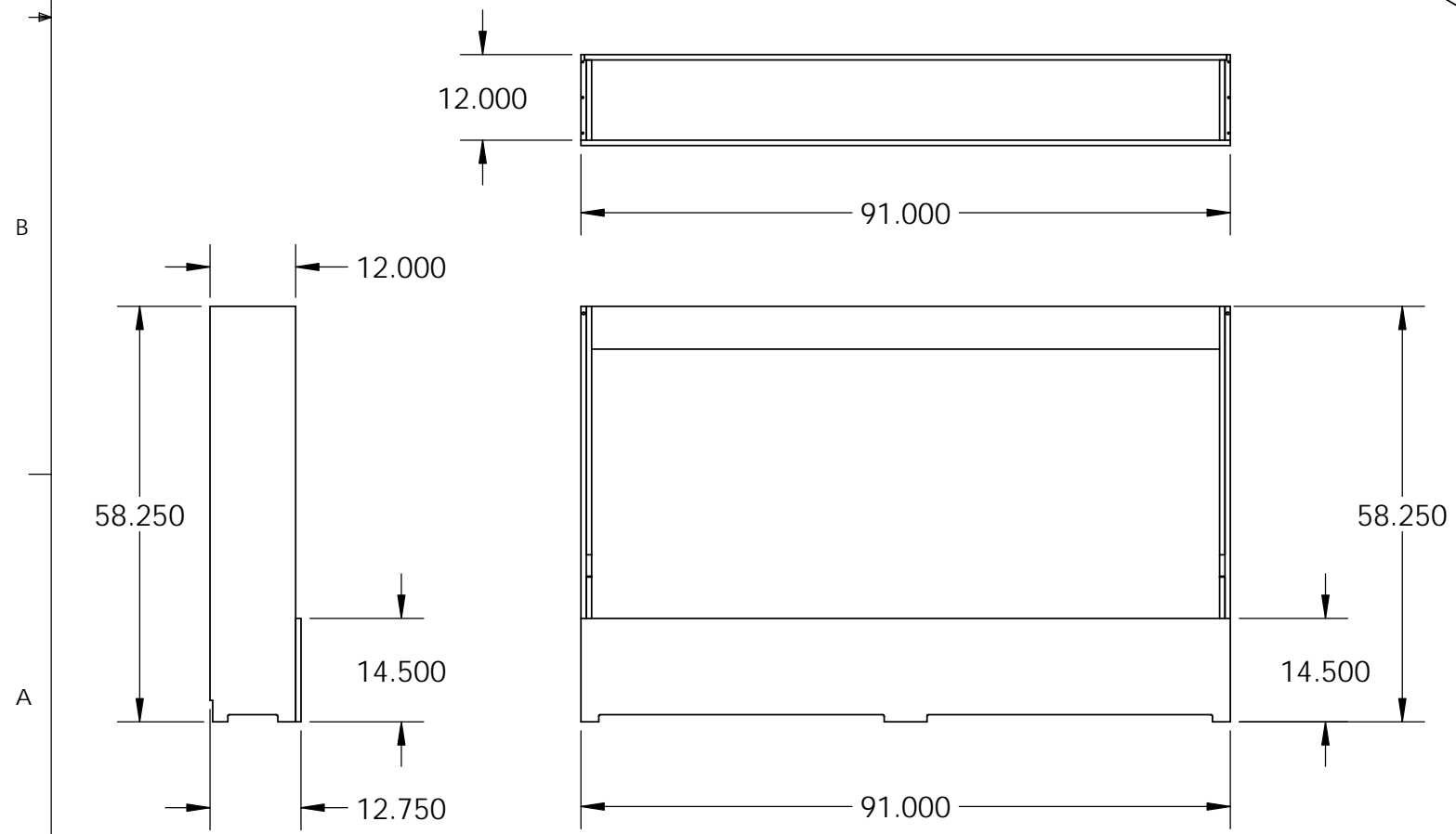
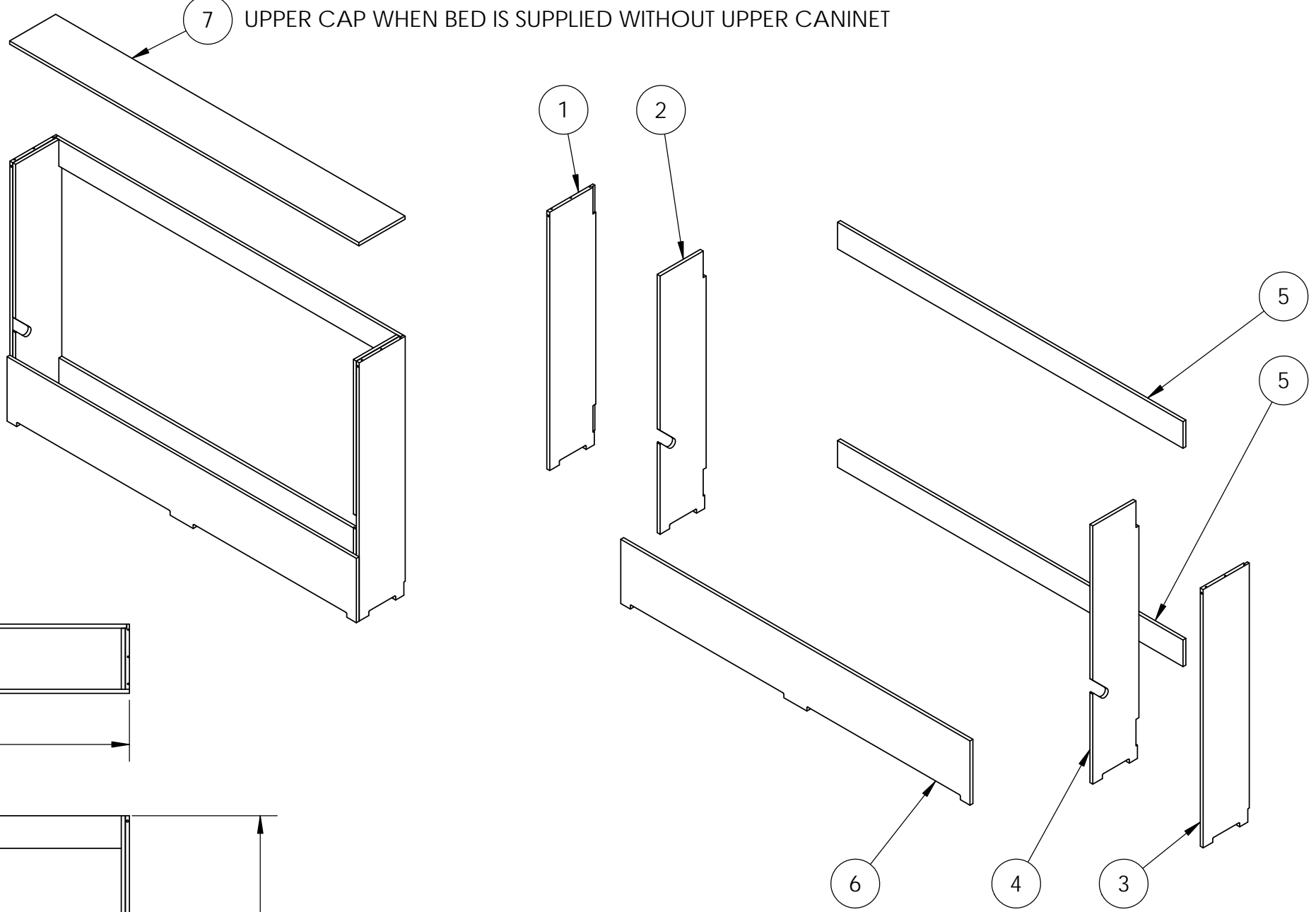

UNLESS OTHERWISE SPECIFIED: DIMENSIONS ARE IN INCHES AND INCLUDE THICKNESS OF PLATING TOLERANCES:	NAME		DATE
	DESIGN BY		
	DRAWN BY		DBC 03/05/14
	CHECKED BY		
TOLERANCES ON:			APPROVED BY
BASIC DIMENSIONS	2 PLACE DECIMALS	3 PLACE DECIMALS	PROPRIETARY AND CONFIDENTIAL THE INFORMATION CONTAINED IN THIS DRAWING IS THE PROPERTY OF DONALD B. CHEKE, SOLE PROPRIETOR OF TEXTUAL CREATIONS. COPYRIGHT 2014. ANY REPRODUCTION IN PART OR AS A WHOLE WITHOUT THE WRITTEN PERMISSION OF TEXTUAL CREATIONS IS PROHIBITED.
UP TO 6	±.02	±.005	
6 TO 24	±.03	±.010	
ABOVE 24	±.06	±.015	
ANGULAR DIMENSIONS ± 0.5°			
MATERIAL:			
FINISH:			

TextualCreations
MORE THAN JUST WORDS ON PAPER

TITLE:
UPRIGHT CASE ASSEMBLY

SIZE B	DWG. NO.	REV
SCALE: 1:25	WG:	SHEET 4 OF 32

ITEM NO.	PART NUMBER	QTY.
1	Upper Cabinet Horz Panel 1	1
2	Upper Cabinet Horz Panel 2	1
3	Upper Cabinet Horz Panel 3	1
4	Upper Cabinet Shelf Divider	6
5	Upper Cabinet Back Panel	1
6	Upper Cabinet Side Panel	1
7	MirrorUpper Cabinet Side Panel	1
8	Upper Cabinet Door	4
9	MirrorUpper Cabinet Door	4
10	#8-32 PH PHD ZN MACHINE SCREW (1.000)	16
11	3.5 inch Wire Pull	8

REVISIONS				
REV.	ZONE	DESCRIPTION	DATE	BY

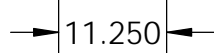
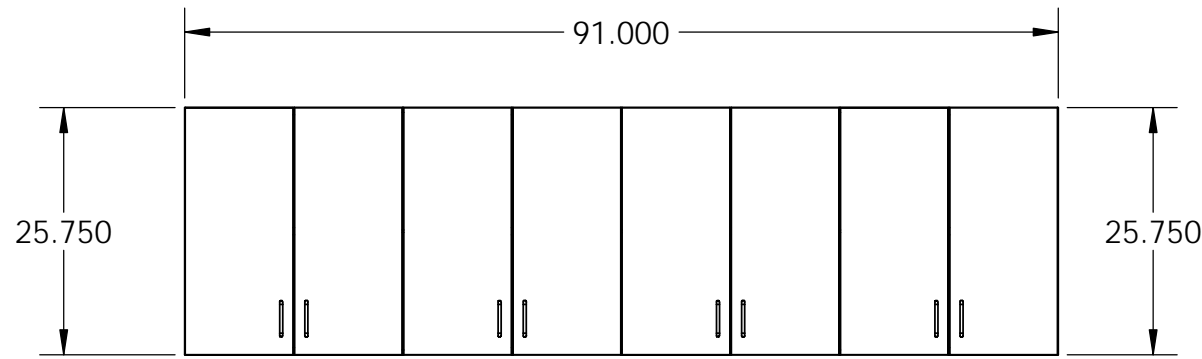
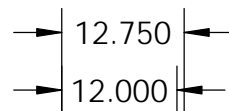
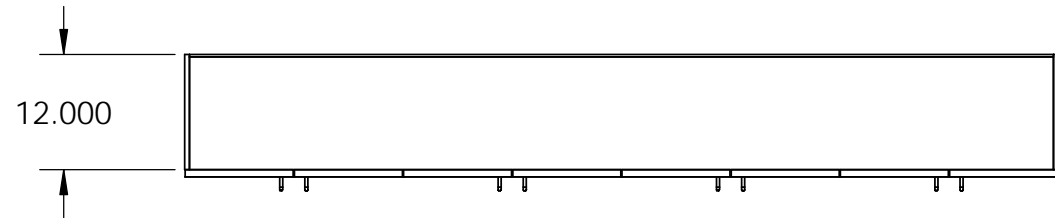
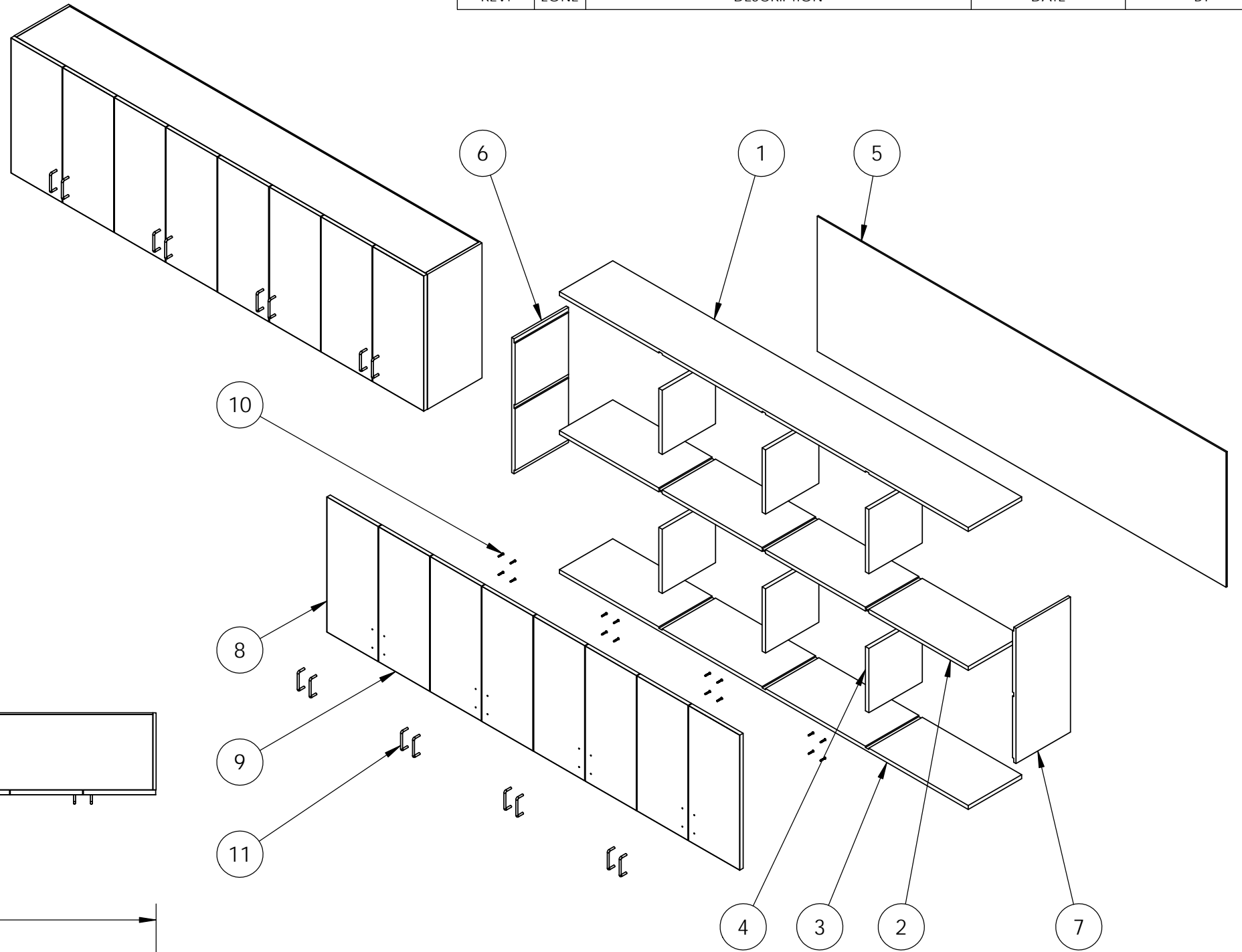

UNLESS OTHERWISE SPECIFIED:
DIMENSIONS ARE IN INCHES
AND INCLUDE THICKNESS OF PLATING
TOLERANCES:

BASIC DIMENSIONS	2 PLACE DECIMALS	3 PLACE DECIMALS
UP TO 6	±.02	±.005
6 TO 24	±.03	±.010
ABOVE 24	±.06	±.015

ANGULAR DIMENSIONS ± 0.5°
MATERIAL:
FINISH:

NAME	DATE
DESIGN BY	
DRAWN BY	DBC 05/03/14
CHECKED BY	
APPROVED BY	

PROPRIETARY AND CONFIDENTIAL
THE INFORMATION CONTAINED IN THIS DRAWING IS THE PROPERTY OF DONALD B. CHEKE, SOLE PROPRIETOR OF TEXTUAL CREATIONS. COPYRIGHT 2014.
ANY REPRODUCTION IN PART OR AS A WHOLE WITHOUT THE WRITTEN PERMISSION OF TEXTUAL CREATIONS IS PROHIBITED.

TextualCreations
MORE THAN JUST WORDS ON PAPER

TITLE:
UPPER CABINET ASSEMBLY

SIZE B	DWG. NO.	REV
SCALE: 1:20	WG:	SHEET 5 OF 32

ITEM NO.	PART NUMBER	QTY.
1	Platform Back	1
2	Platform Front	1
3	Platform Inner Sheet	1
4	Twin XL Mattress	1
5	Platform Hinge	2
6	#8-18 PH FHD ZN SHEET METAL SCREW (.500)	12
7	Platform Outer End	1
8	Platform Inner End	1
9	Platform Mid End	2
10	MirrorPlatform Inner End	1
11	Platform Lower Cap	1
12	45 Deg Offset Pull (5.000) 1656A100	2
13	.25-20 PH PH ZN MACHINE SCREW (2.000)90272A550	4
14	MirrorPlatform Outer End	1
15	Platform Leg	2
16	Platform Foot for Leg	2
17	#4-.500 OD Washer	2
18	#4-24 PH PHD ZN Sheet Metal Screw (.375)	2

REVISIONS				
REV.	ZONE	DESCRIPTION	DATE	BY

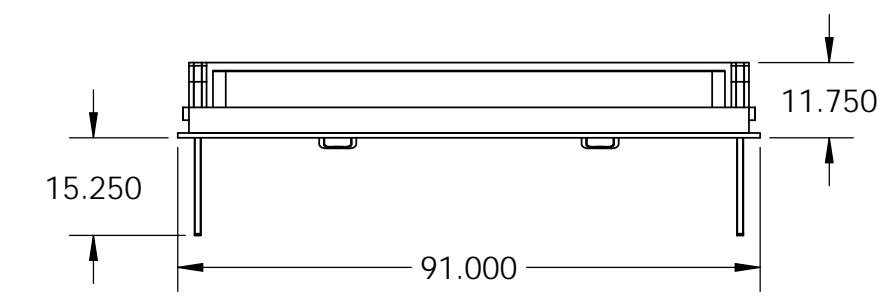
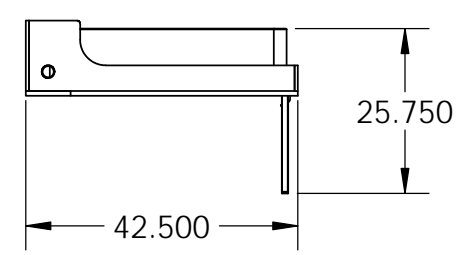
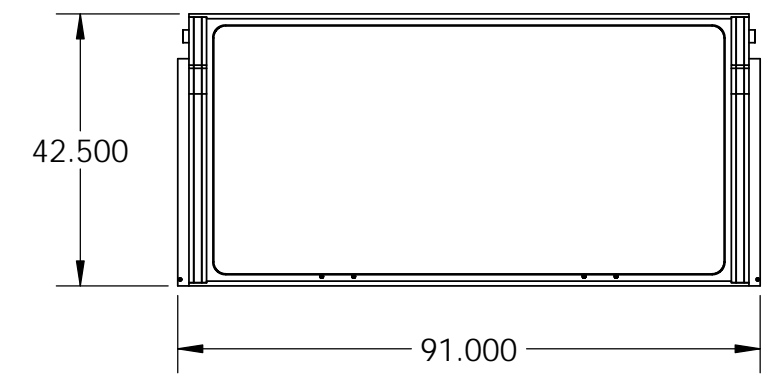
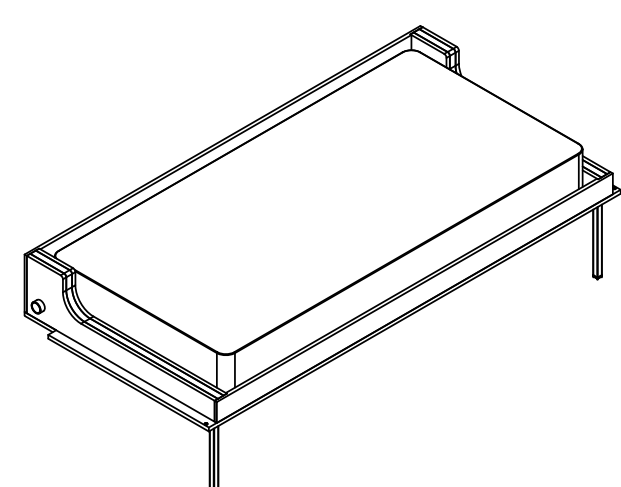
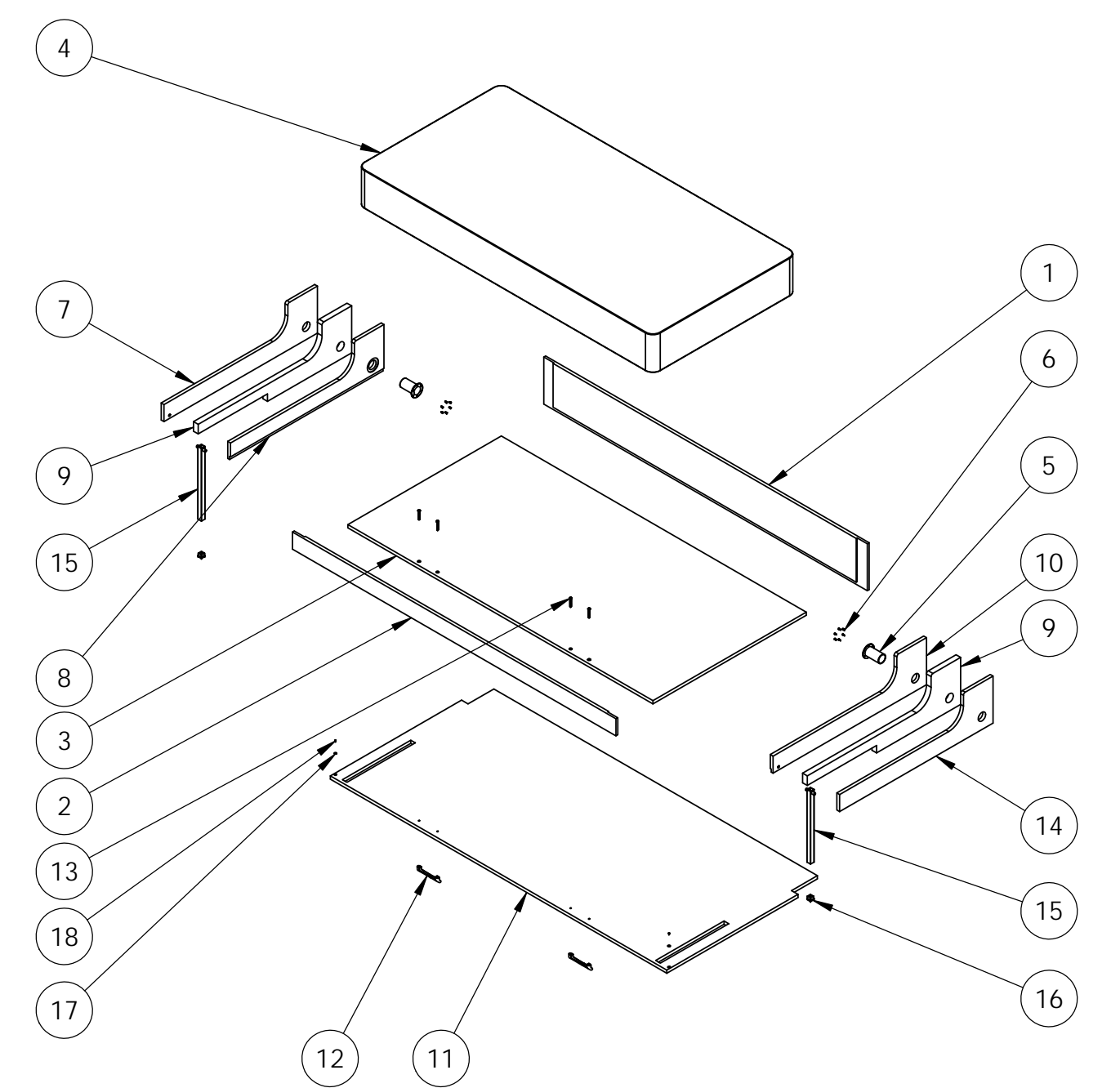

UNLESS OTHERWISE SPECIFIED: DIMENSIONS ARE IN INCHES AND INCLUDE THICKNESS OF PLATING TOLERANCES: TOLERANCES ON: <table border="1"> <tr> <th>BASIC DIMENSIONS</th> <th>2 PLACE DECIMALS</th> <th>3 PLACE DECIMALS</th> </tr> <tr> <td>UP TO 6</td> <td>±.02</td> <td>±.005</td> </tr> <tr> <td>6 TO 24</td> <td>±.03</td> <td>±.010</td> </tr> <tr> <td>ABOVE 24</td> <td>±.06</td> <td>±.015</td> </tr> </table> ANGULAR DIMENSIONS ± 0.5° MATERIAL: FINISH:	BASIC DIMENSIONS	2 PLACE DECIMALS	3 PLACE DECIMALS	UP TO 6	±.02	±.005	6 TO 24	±.03	±.010	ABOVE 24	±.06	±.015	DESIGN BY	NAME	DATE	 TITLE: PLATFORM ASSEMBLY
	BASIC DIMENSIONS	2 PLACE DECIMALS	3 PLACE DECIMALS													
	UP TO 6	±.02	±.005													
	6 TO 24	±.03	±.010													
ABOVE 24	±.06	±.015														
CHECKED BY	DBC	05/03/14														
APPROVED BY																
PROPRIETARY AND CONFIDENTIAL THE INFORMATION CONTAINED IN THIS DRAWING IS THE PROPERTY OF DONALD B. CHEKE, SOLE PROPRIETOR OF TEXTUAL CREATIONS. COPYRIGHT 2014. ANY REPRODUCTION IN PART OR AS A WHOLE WITHOUT THE WRITTEN PERMISSION OF TEXTUAL CREATIONS IS PROHIBITED.																
SIZE	DWG. NO.	REV														
B																
SCALE: 1:30	WG:	SHEET 6 OF 32														

REVISIONS				
REV.	ZONE	DESCRIPTION	DATE	BY

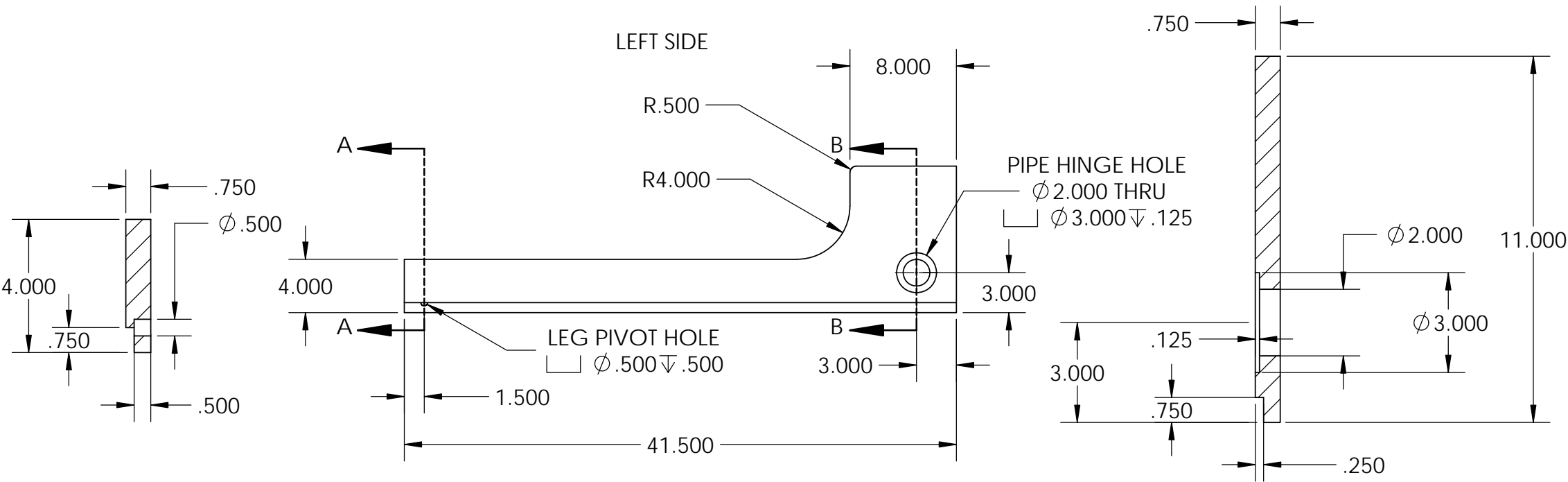
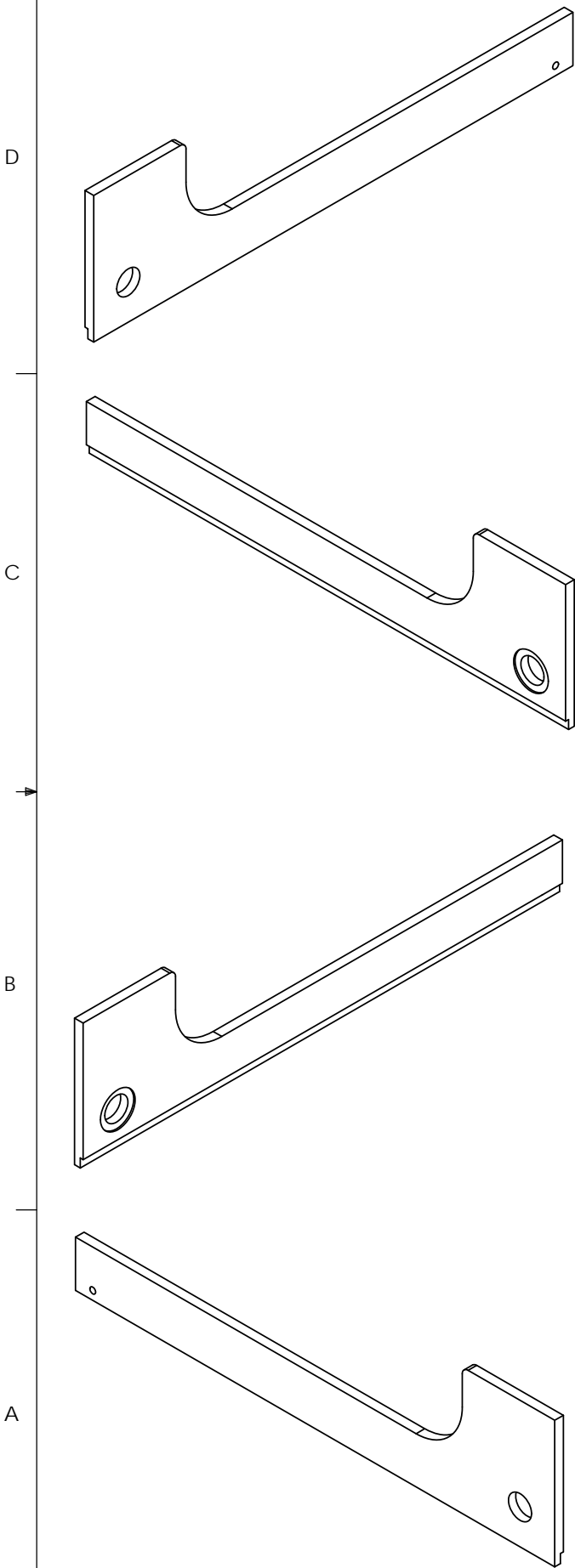

SECTION A-A
 SCALE 1 : 4

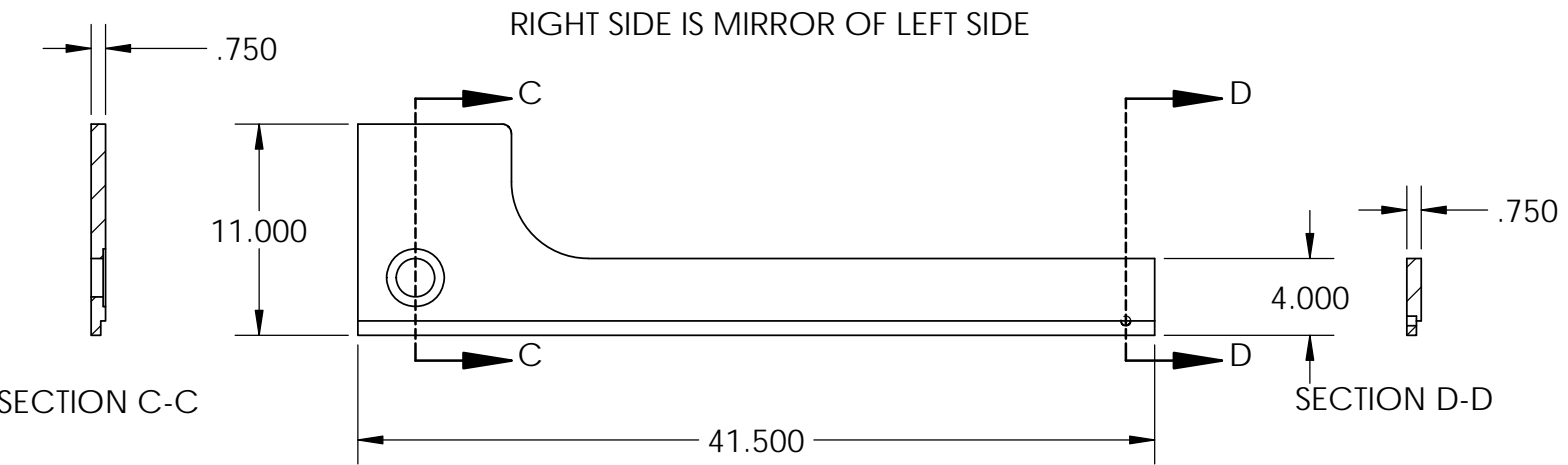

UNLESS OTHERWISE SPECIFIED: DIMENSIONS ARE IN INCHES AND INCLUDE THICKNESS OF PLATING TOLERANCES: TOLERANCES ON: <table border="1"> <tr> <th>BASIC DIMENSIONS</th> <th>2 PLACE DECIMALS</th> <th>3 PLACE DECIMALS</th> </tr> <tr> <td>UP TO 6</td> <td>\pm.02</td> <td>\pm.005</td> </tr> <tr> <td>6 TO 24</td> <td>\pm.03</td> <td>\pm.010</td> </tr> <tr> <td>ABOVE 24</td> <td>\pm.06</td> <td>\pm.015</td> </tr> </table> ANGULAR DIMENSIONS \pm 0.5° MATERIAL: PLYWOOD FINISH: STAIN & LACQUER	BASIC DIMENSIONS	2 PLACE DECIMALS	3 PLACE DECIMALS	UP TO 6	\pm .02	\pm .005	6 TO 24	\pm .03	\pm .010	ABOVE 24	\pm .06	\pm .015	DESIGN BY	NAME	DATE	<p>Textual Creations MORE THAN JUST WORDS ON PAPER</p> <p>TITLE: PLATFORM INNER ENDS</p> <table border="1"> <tr> <td>SIZE</td> <td>DWG. NO.</td> <td>REV</td> </tr> <tr> <td>B</td> <td> </td> <td> </td> </tr> </table> <p>SCALE: 1:10 WG: SHEET 7 OF 32</p>	SIZE	DWG. NO.	REV	B		
	BASIC DIMENSIONS	2 PLACE DECIMALS	3 PLACE DECIMALS																			
	UP TO 6	\pm .02	\pm .005																			
	6 TO 24	\pm .03	\pm .010																			
ABOVE 24	\pm .06	\pm .015																				
SIZE	DWG. NO.	REV																				
B																						
DRAWN BY	DBC	05/03/14																				
CHECKED BY																						
APPROVED BY																						
PROPRIETARY AND CONFIDENTIAL THE INFORMATION CONTAINED IN THIS DRAWING IS THE PROPERTY OF DONALD B. CHEKE, SOLE PROPRIETOR OF TEXTUAL CREATIONS. COPYRIGHT 2014. ANY REPRODUCTION IN PART OR AS A WHOLE WITHOUT THE WRITTEN PERMISSION OF TEXTUAL CREATIONS IS PROHIBITED.																						

8 7 6 5 4 3 2 1

REVISIONS				
REV.	ZONE	DESCRIPTION	DATE	BY

D

D

C

C

B

B

A

A

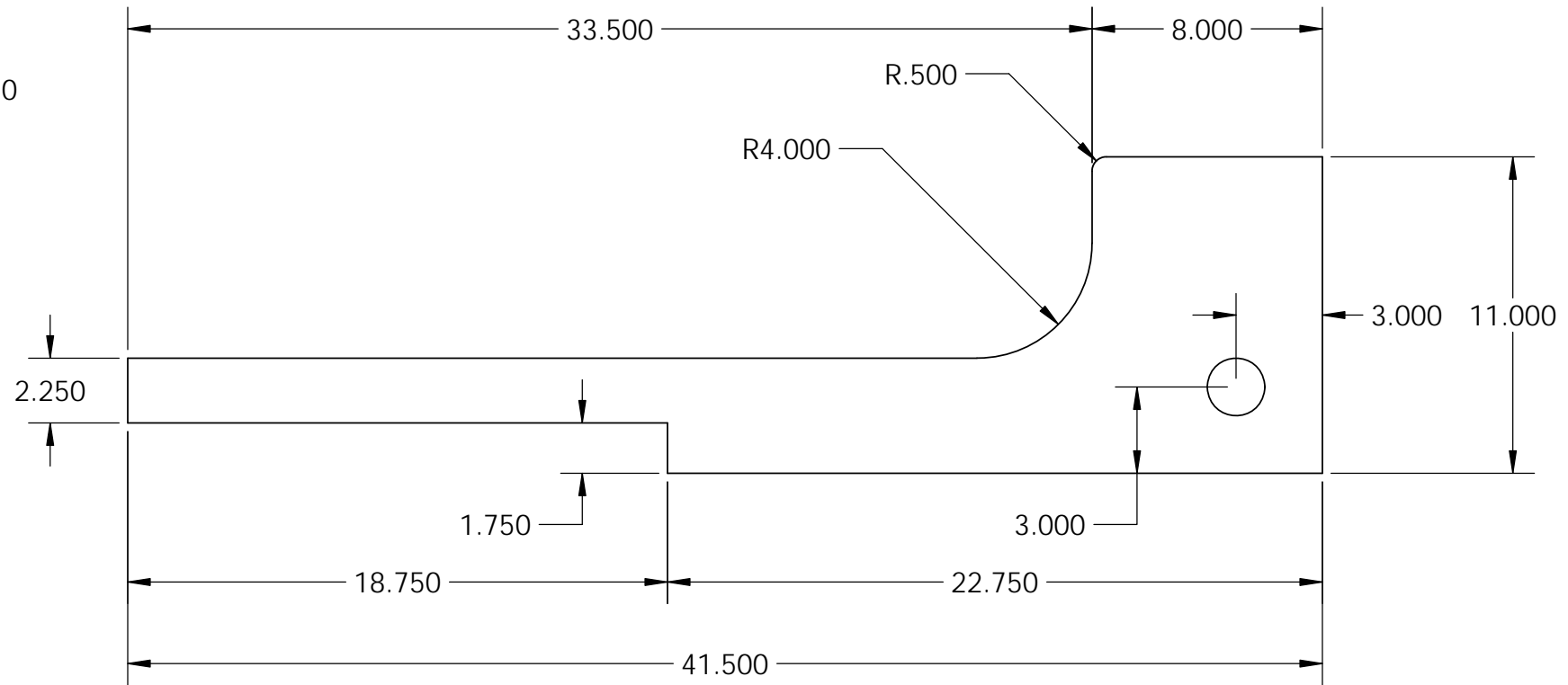
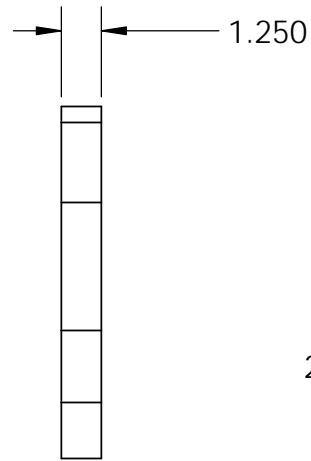
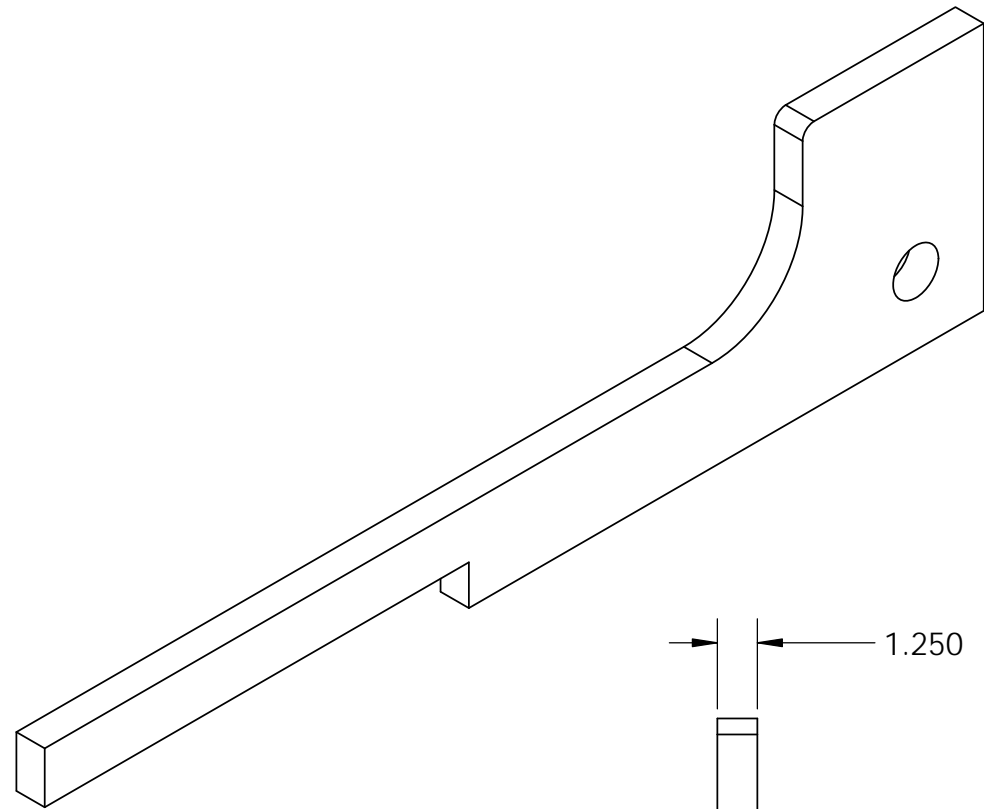

LEFT AND RIGHT SIDE ARE IDENTICAL

MATERIAL NOTE:
BIRCH PLYWOOD WITH VENEER
WOOD TAPE ON EXPOSED EDGES

UNLESS OTHERWISE SPECIFIED: DIMENSIONS ARE IN INCHES AND INCLUDE THICKNESS OF PLATING TOLERANCES: <table border="1"> <tr> <th colspan="3">TOLERANCES ON:</th> </tr> <tr> <th>BASIC DIMENSIONS</th> <th>2 PLACE DECIMALS</th> <th>3 PLACE DECIMALS</th> </tr> <tr> <td>UP TO 6</td> <td>±.02</td> <td>±.005</td> </tr> <tr> <td>6 TO 24</td> <td>±.03</td> <td>±.010</td> </tr> <tr> <td>ABOVE 24</td> <td>±.06</td> <td>±.015</td> </tr> </table> ANGULAR DIMENSIONS ± 0.5° MATERIAL: PLYWOOD FINISH: STAIN & LACQUER	TOLERANCES ON:			BASIC DIMENSIONS	2 PLACE DECIMALS	3 PLACE DECIMALS	UP TO 6	±.02	±.005	6 TO 24	±.03	±.010	ABOVE 24	±.06	±.015	DESIGN BY	NAME	DATE	
	TOLERANCES ON:																		
	BASIC DIMENSIONS	2 PLACE DECIMALS	3 PLACE DECIMALS																
	UP TO 6	±.02	±.005																
6 TO 24	±.03	±.010																	
ABOVE 24	±.06	±.015																	
DRAWN BY	DBC	05/03/14																	
CHECKED BY																			
APPROVED BY																			
PROPRIETARY AND CONFIDENTIAL THE INFORMATION CONTAINED IN THIS DRAWING IS THE PROPERTY OF DONALD B. CHEKE, SOLE PROPRIETOR OF TEXTUAL CREATIONS. COPYRIGHT 2014. ANY REPRODUCTION IN PART OR AS A WHOLE WITHOUT THE WRITTEN PERMISSION OF TEXTUAL CREATIONS IS PROHIBITED.				TITLE: PLATFORM MID ENDS															
SIZE		DWG. NO.	REV																
B																			
SCALE: 1:6		WG:	SHEET 8 OF 32																

REVISIONS				
REV.	ZONE	DESCRIPTION	DATE	BY

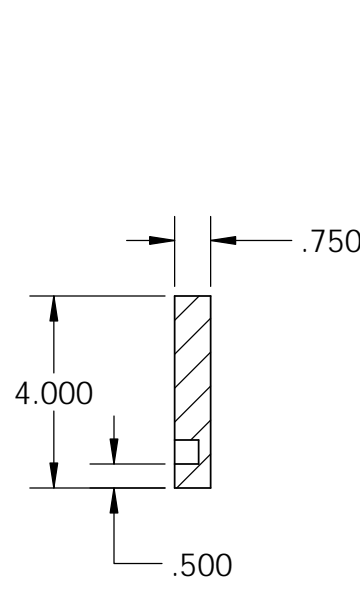
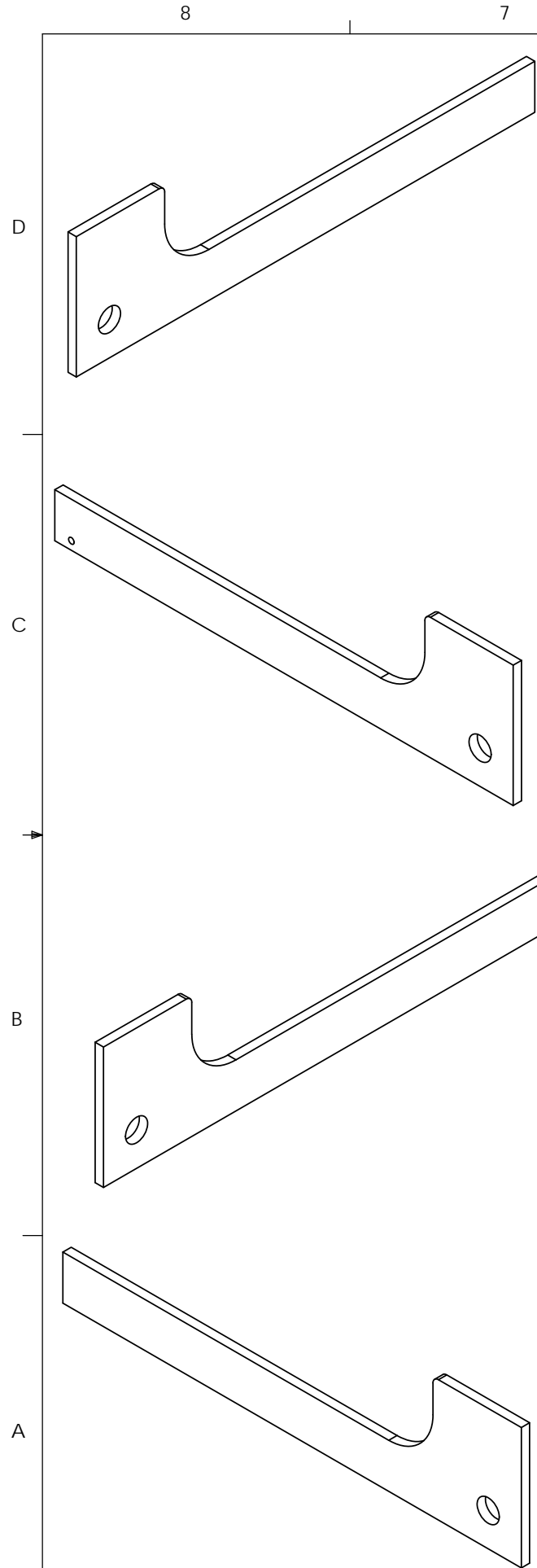

SECTION E-E
SCALE 1 : 4

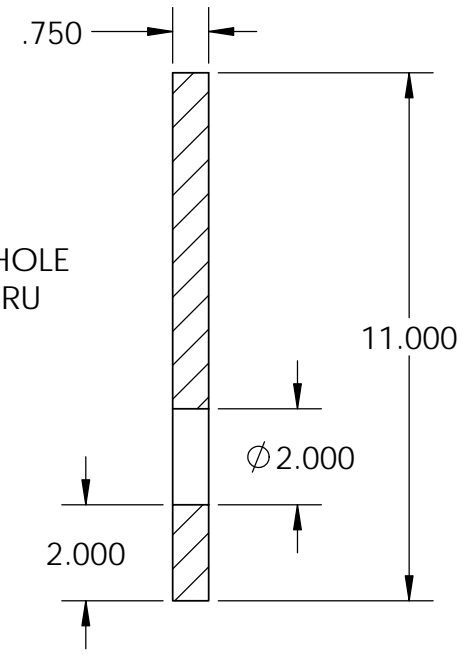
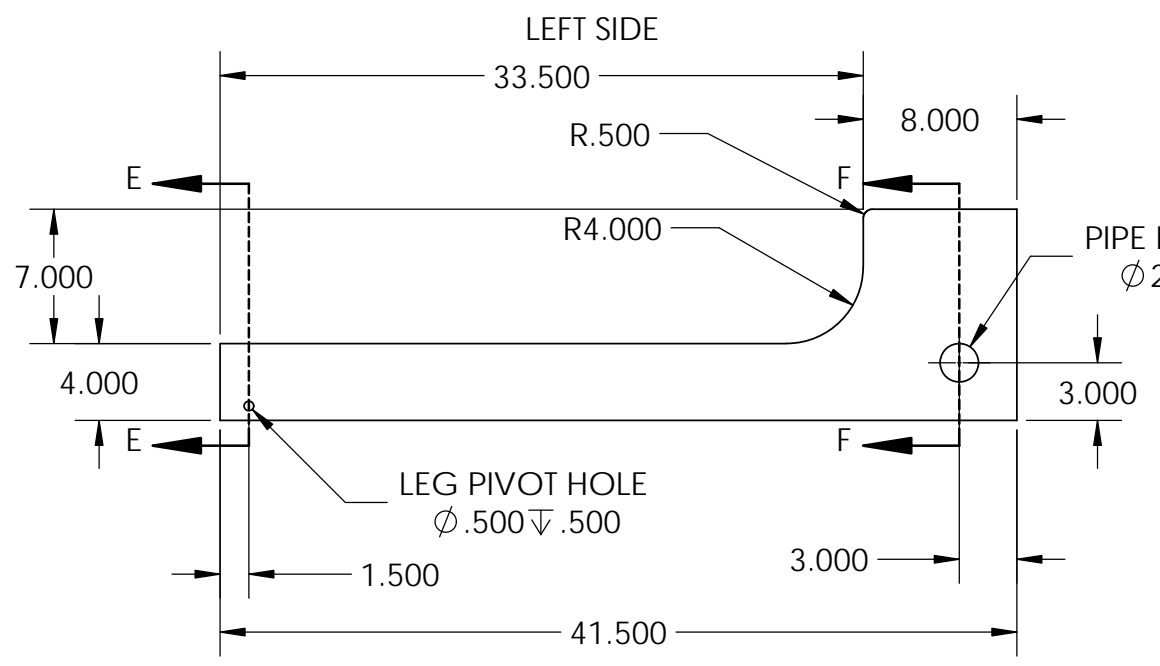

SECTION F-F
SCALE 1 : 4

RIGHT SIDE IS MIRROR OF LEFT SIDE

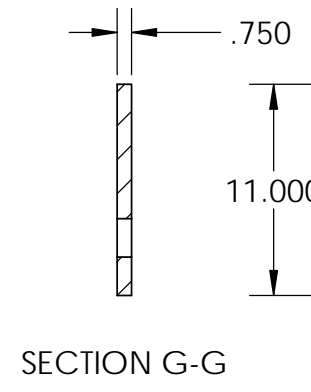

SECTION G-G

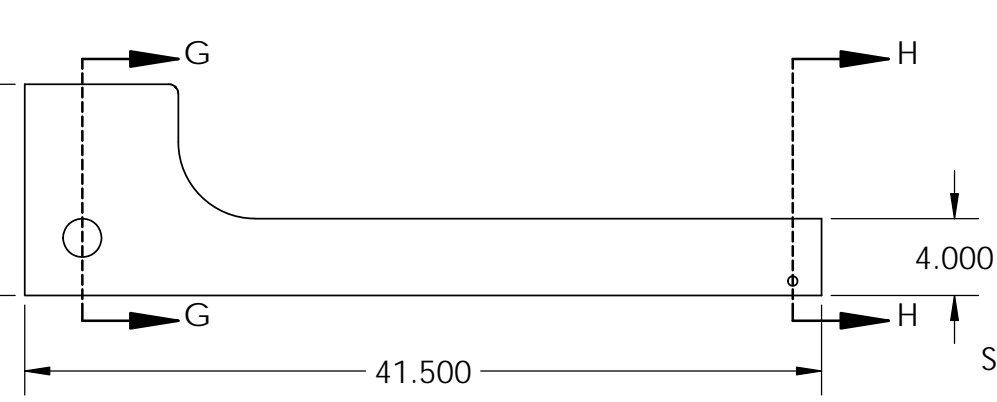

SECTION H-H

UNLESS OTHERWISE SPECIFIED:
DIMENSIONS ARE IN INCHES
AND INCLUDE THICKNESS OF PLATING
TOLERANCES:

BASIC DIMENSIONS	2 PLACE DECIMALS	3 PLACE DECIMALS
UP TO 6	±.02	±.005
6 TO 24	±.03	±.010
ABOVE 24	±.06	±.015

ANGULAR DIMENSIONS ± 0.5°
MATERIAL:
PLYWOOD
FINISH:
STAIN & LACQUER

	NAME	DATE
DESIGN BY		
DRAWN BY	DBC	05/03/14
CHECKED BY		
APPROVED BY		

PROPRIETARY AND CONFIDENTIAL
THE INFORMATION CONTAINED IN THIS DRAWING IS THE PROPERTY OF DONALD B. CHEKE, SOLE PROPRIETOR OF TEXTUAL CREATIONS. COPYRIGHT 2014.
ANY REPRODUCTION IN PART OR AS A WHOLE WITHOUT THE WRITTEN PERMISSION OF TEXTUAL CREATIONS IS PROHIBITED.

TextualCreations
MORE THAN JUST WORDS ON PAPER

TITLE:
PLATFORM OUTER ENDS

SIZE B	DWG. NO.	REV
SCALE: 1:10	WG:	SHEET 9 OF 32

REVISIONS				
REV.	ZONE	DESCRIPTION	DATE	BY

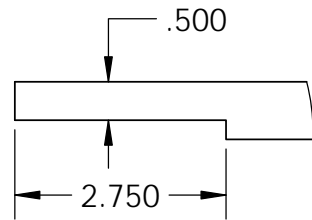

DETAIL I
SCALE 2 : 5

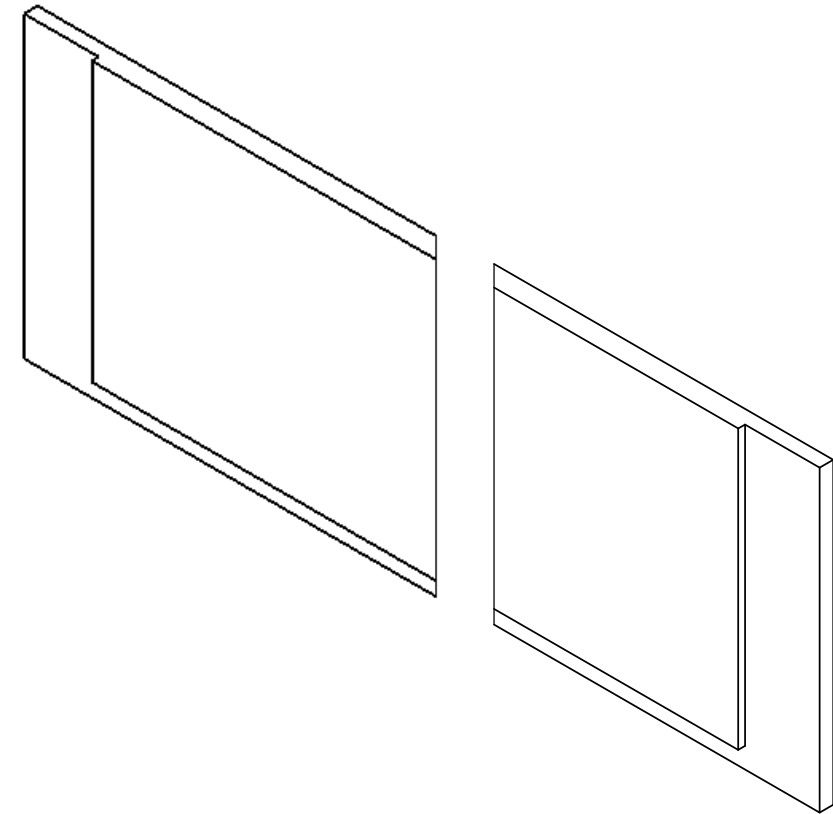
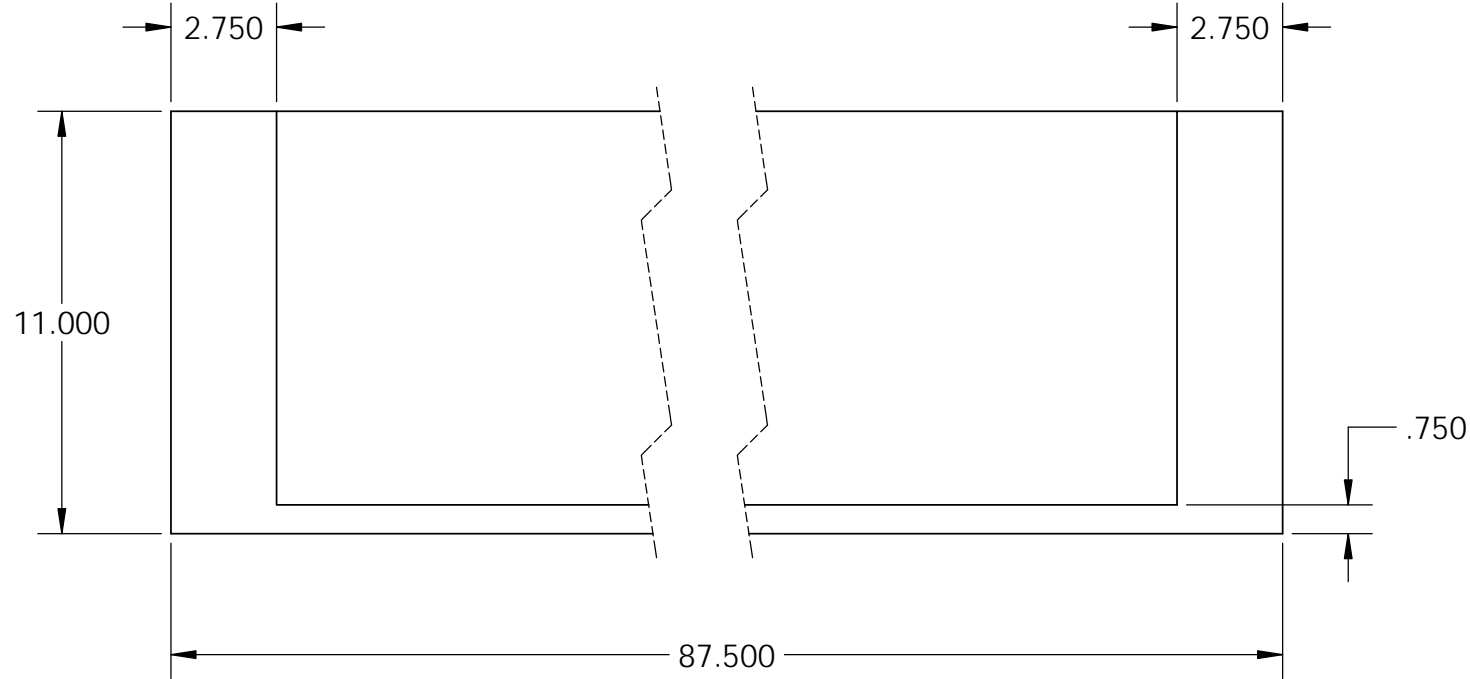
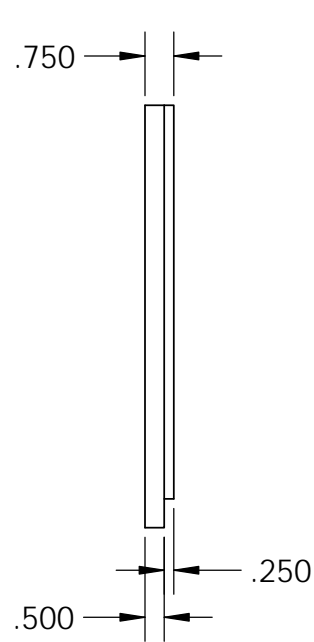
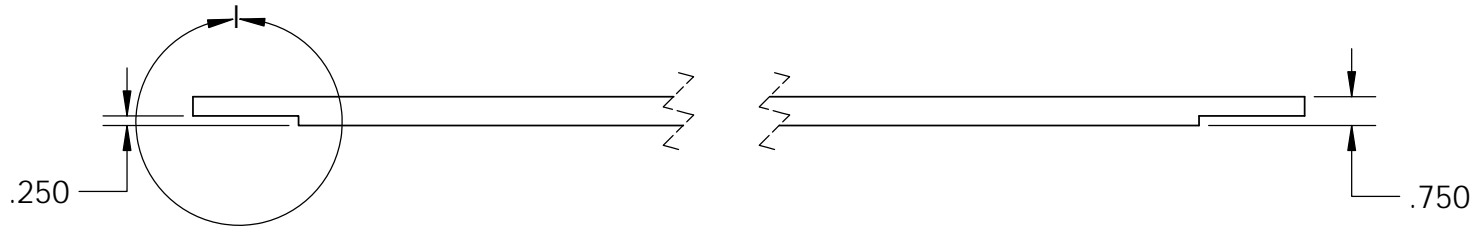

UNLESS OTHERWISE SPECIFIED:
DIMENSIONS ARE IN INCHES
AND INCLUDE THICKNESS OF PLATING
TOLERANCES:

BASIC DIMENSIONS	2 PLACE DECIMALS	3 PLACE DECIMALS
UP TO 6	±.02	±.005
6 TO 24	±.03	±.010
ABOVE 24	±.06	±.015

ANGULAR DIMENSIONS ± 0.5°
MATERIAL:
PLYWOOD
FINISH:
STAIN & LACQUER

	NAME	DATE
DESIGN BY		
DRAWN BY	DBC	05/03/14
CHECKED BY		
APPROVED BY		

PROPRIETARY AND CONFIDENTIAL
THE INFORMATION CONTAINED IN THIS DRAWING IS THE PROPERTY OF TEXTUAL CREATIONS. COPYRIGHT 2014. ANY REPRODUCTION IN PART OR AS A WHOLE WITHOUT WRITTEN PERMISSION OF TEXTUAL CREATIONS IS PROHIBITED.



TITLE: PLATFORM BACK		
SIZE B	DWG. NO.	REV
SCALE: 1:5	WG:	SHEET 10 OF 32

REVISIONS				
REV.	ZONE	DESCRIPTION	DATE	BY

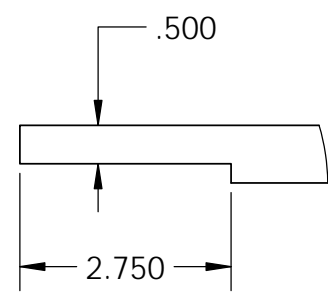

DETAIL J
SCALE 2 : 5

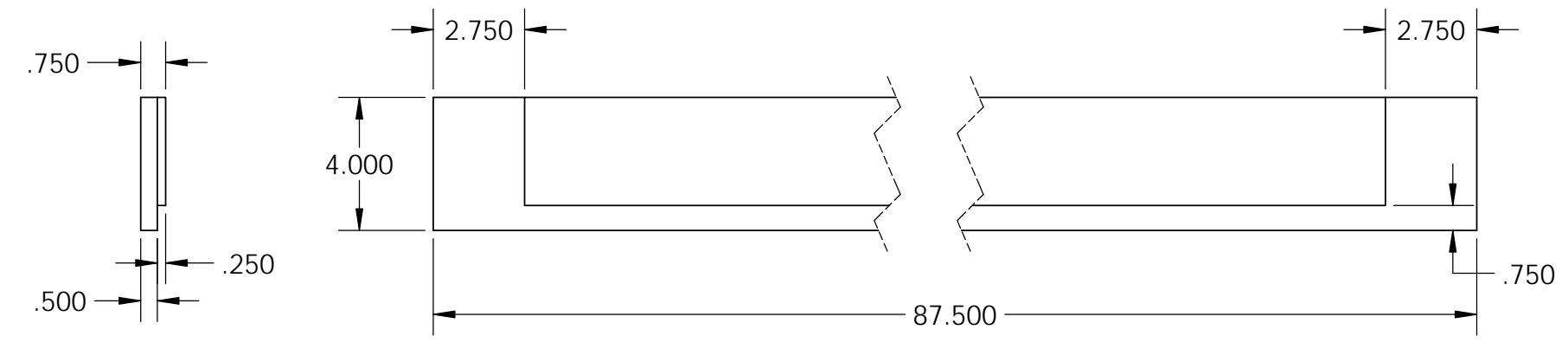
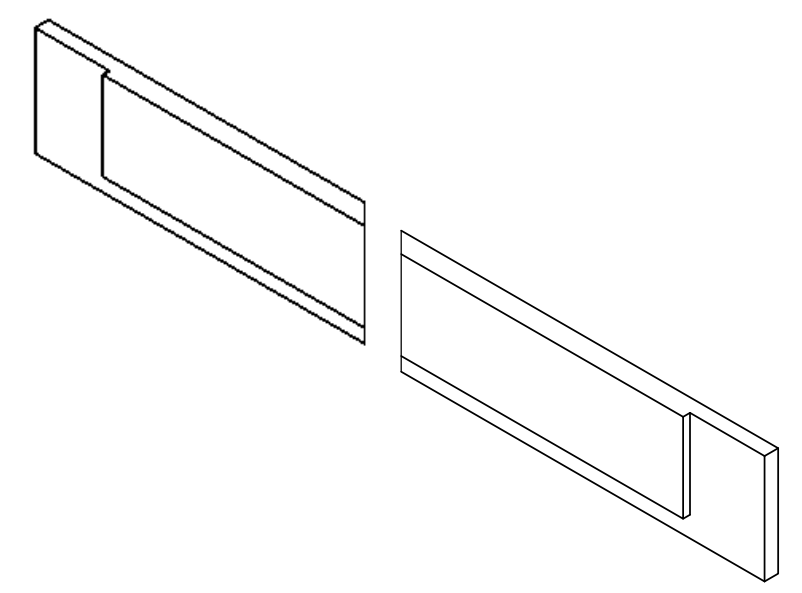
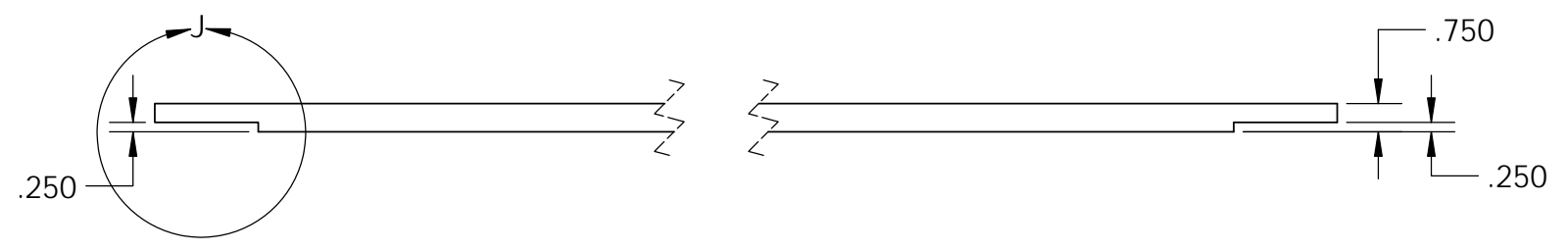

UNLESS OTHERWISE SPECIFIED:
DIMENSIONS ARE IN INCHES
AND INCLUDE THICKNESS OF PLATING
TOLERANCES:

BASIC DIMENSIONS	2 PLACE DECIMALS	3 PLACE DECIMALS
UP TO 6	±.02	±.005
6 TO 24	±.03	±.010
ABOVE 24	±.06	±.015

ANGULAR DIMENSIONS ± 0.5°
MATERIAL:
PLYWOOD
FINISH:
STAIN & LACQUER

NAME	DATE
DESIGN BY	
DRAWN BY	DBC 05/03/14
CHECKED BY	
APPROVED BY	

PROPRIETARY AND CONFIDENTIAL
THE INFORMATION CONTAINED IN THIS DRAWING IS THE PROPERTY OF DONALD B. CHEKE, SOLE PROPRIETOR OF TEXTUAL CREATIONS. COPYRIGHT 2014.
ANY REPRODUCTION IN PART OR AS A WHOLE WITHOUT THE WRITTEN PERMISSION OF TEXTUAL CREATIONS IS PROHIBITED.

TextualCreations
MORE THAN JUST WORDS ON PAPER

TITLE:
PLATFORM FRONT

SIZE B	DWG. NO.	REV
SCALE: 1:5	WG:	SHEET 11 OF 32

REVISIONS				
REV.	ZONE	DESCRIPTION	DATE	BY

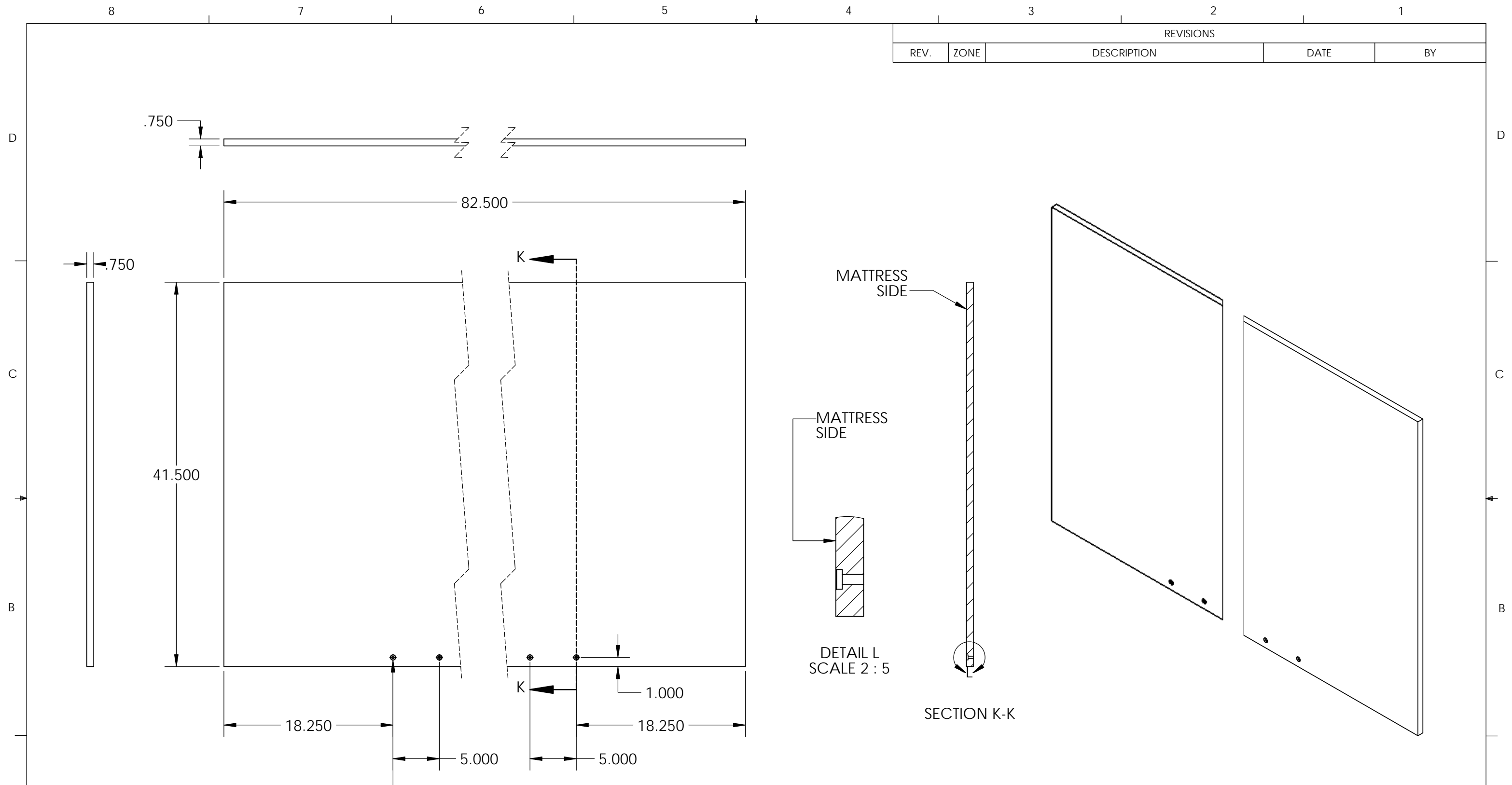

4X ϕ .266 THRU ALL
 \square ϕ .531 ∇ .175
 \sphericalangle ϕ .581 X 90°, NEAR SIDE

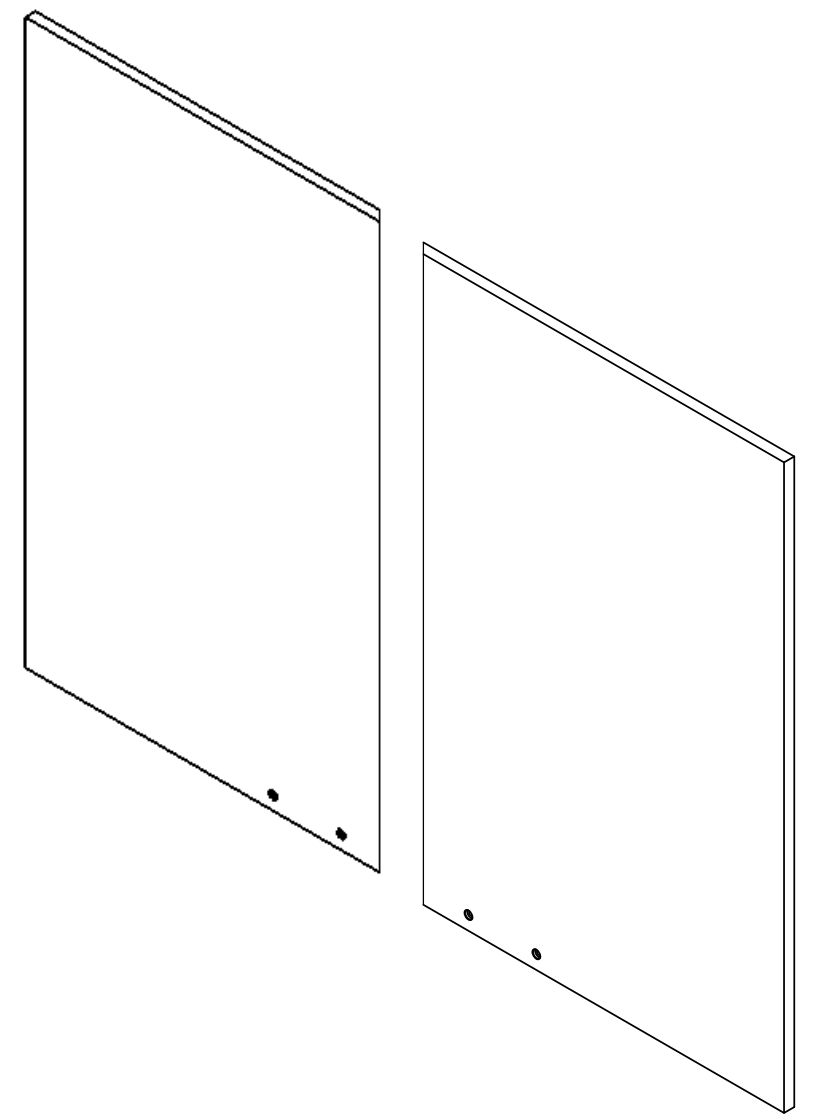
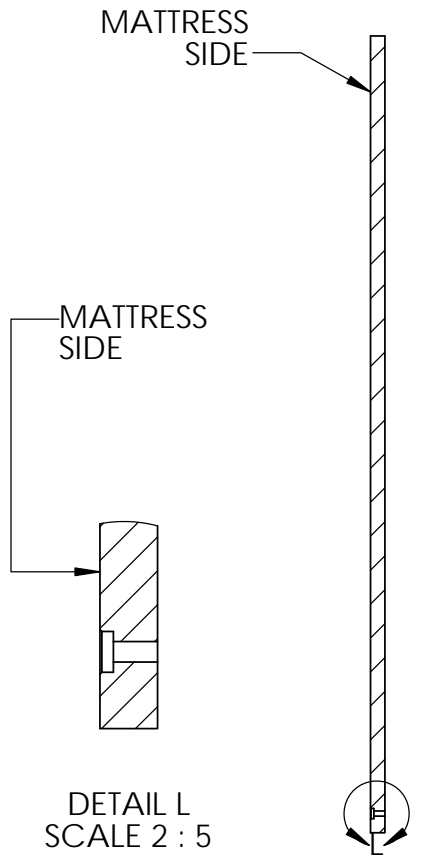

UNLESS OTHERWISE SPECIFIED:
 DIMENSIONS ARE IN INCHES
 AND INCLUDE THICKNESS OF PLATING
 TOLERANCES:

BASIC DIMENSIONS	2 PLACE DECIMALS	3 PLACE DECIMALS
UP TO 6	±.02	±.005
6 TO 24	±.03	±.010
ABOVE 24	±.06	±.015

ANGULAR DIMENSIONS ± 0.5°
 MATERIAL:
 PLYWOOD
 FINISH:
 STAIN & LACQUER

NAME	DATE
DESIGN BY	
DRAWN BY	DBC 05/03/14
CHECKED BY	
APPROVED BY	

PROPRIETARY AND CONFIDENTIAL
 THE INFORMATION CONTAINED IN THIS DRAWING IS THE PROPERTY OF DONALD B. CHEKE, SOLE PROPRIETOR OF TEXTUAL CREATIONS. COPYRIGHT 2014.
 ANY REPRODUCTION IN PART OR AS A WHOLE WITHOUT THE WRITTEN PERMISSION OF TEXTUAL CREATIONS IS PROHIBITED.

TextualCreations
 MORE THAN JUST WORDS ON PAPER

TITLE:
PLATFORM INNER SHEET

SIZE	DWG. NO.	REV
B		

SCALE: 1:10 WG: SHEET 12 OF 32

REVISIONS				
REV.	ZONE	DESCRIPTION	DATE	BY

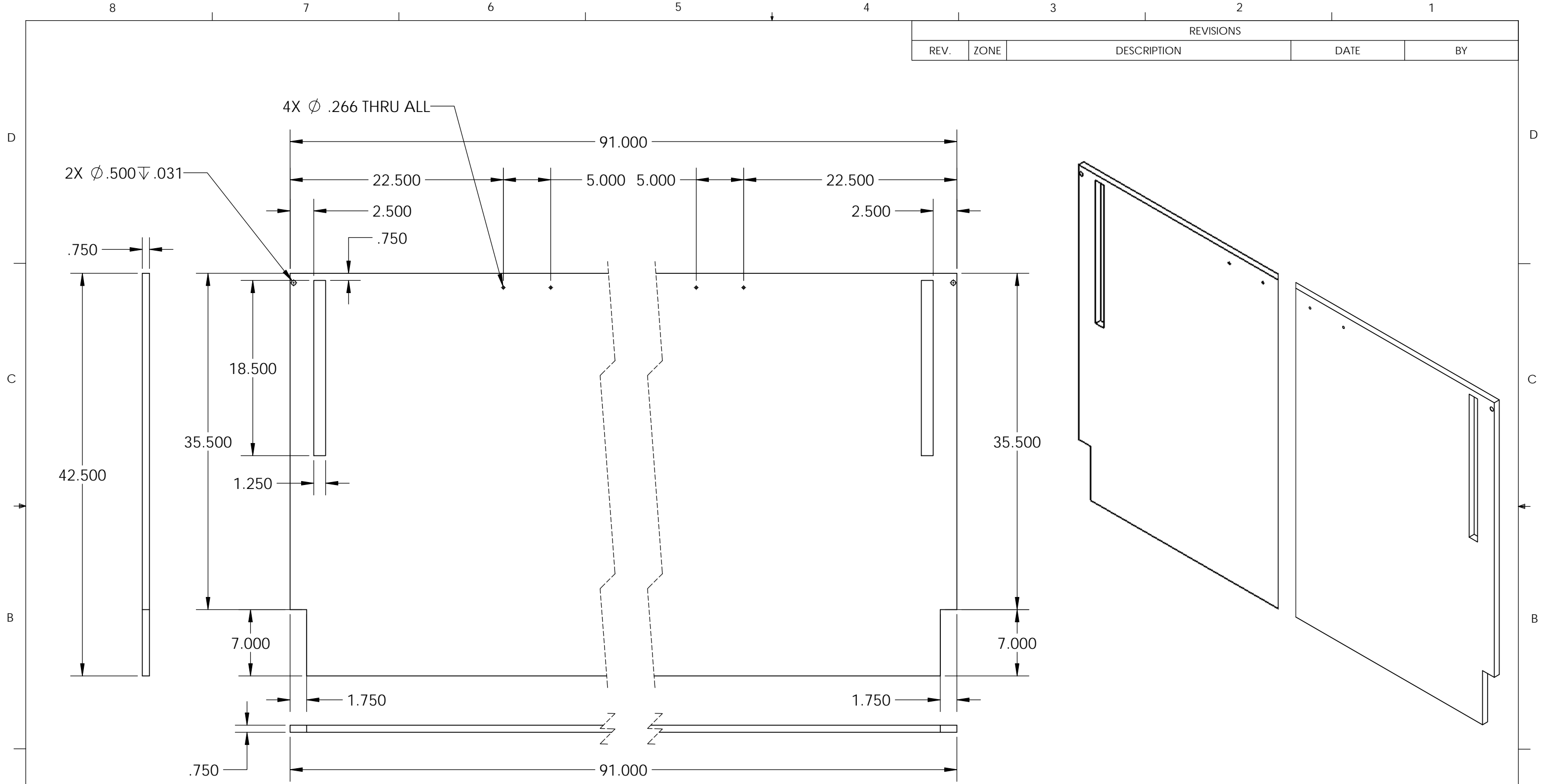

UNLESS OTHERWISE SPECIFIED:
DIMENSIONS ARE IN INCHES
AND INCLUDE THICKNESS OF PLATING
TOLERANCES:

BASIC DIMENSIONS	2 PLACE DECIMALS	3 PLACE DECIMALS
UP TO 6	±.02	±.005
6 TO 24	±.03	±.010
ABOVE 24	±.06	±.015

ANGULAR DIMENSIONS ± 0.5°
MATERIAL:
PLYWOOD
FINISH:
STAIN & LACQUER

	NAME	DATE
DESIGN BY		
DRAWN BY	DBC	05/03/14
CHECKED BY		
APPROVED BY		

PROPRIETARY AND CONFIDENTIAL
THE INFORMATION CONTAINED IN THIS DRAWING IS THE PROPERTY OF DONALD B. CHEKE, SOLE PROPRIETOR OF TEXTUAL CREATIONS. COPYRIGHT 2014.
ANY REPRODUCTION IN PART OR AS A WHOLE WITHOUT THE WRITTEN PERMISSION OF TEXTUAL CREATIONS IS PROHIBITED.

TextualCreations
MORE THAN JUST WORDS ON PAPER

TITLE:
PLATFORM LOWER (OUTER) CAP

SIZE B	DWG. NO.	REV
SCALE: 1:10	WG:	SHEET 13 OF 32

A

A

B

B

C

C

D

D

8

7

6

5

4

3

2

1

8

7

6

5

4

3

2

1

REVISIONS				
REV.	ZONE	DESCRIPTION	DATE	BY

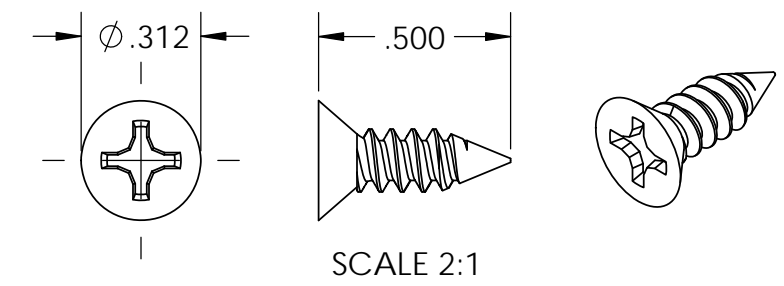
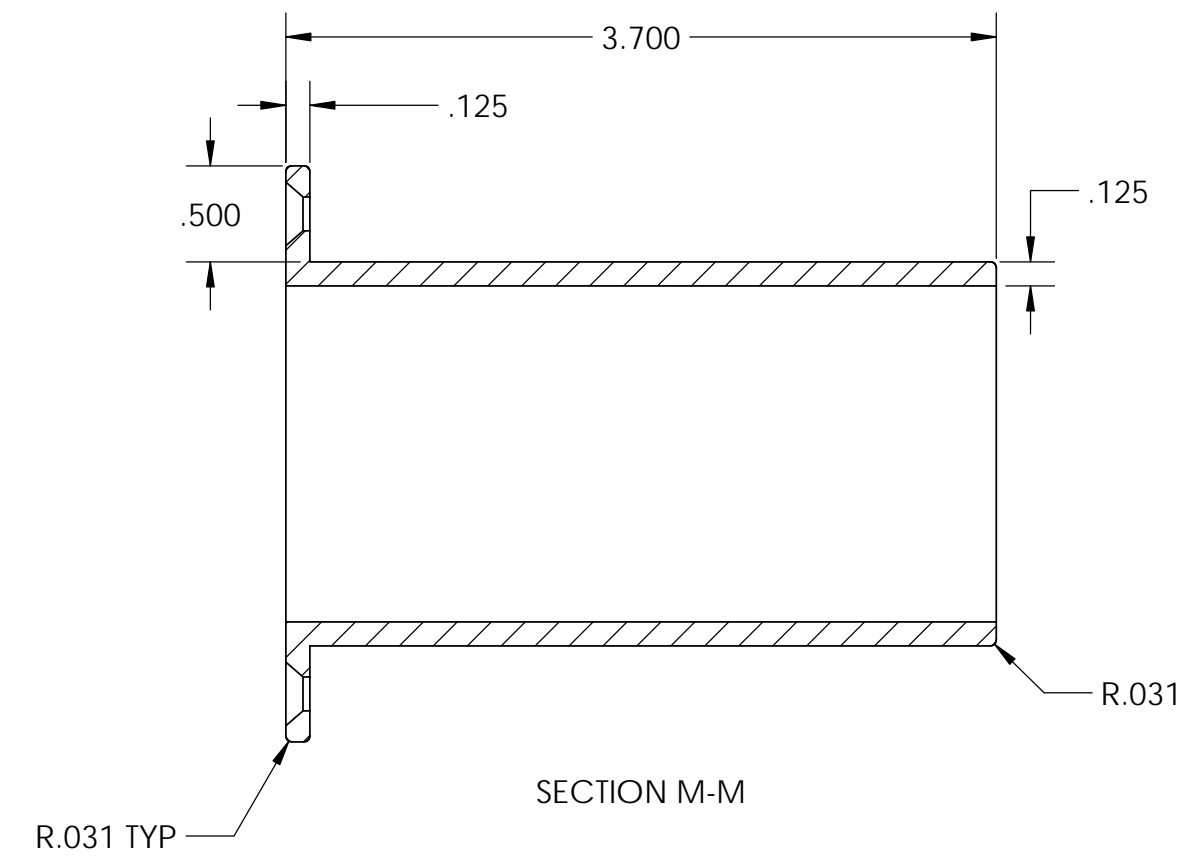
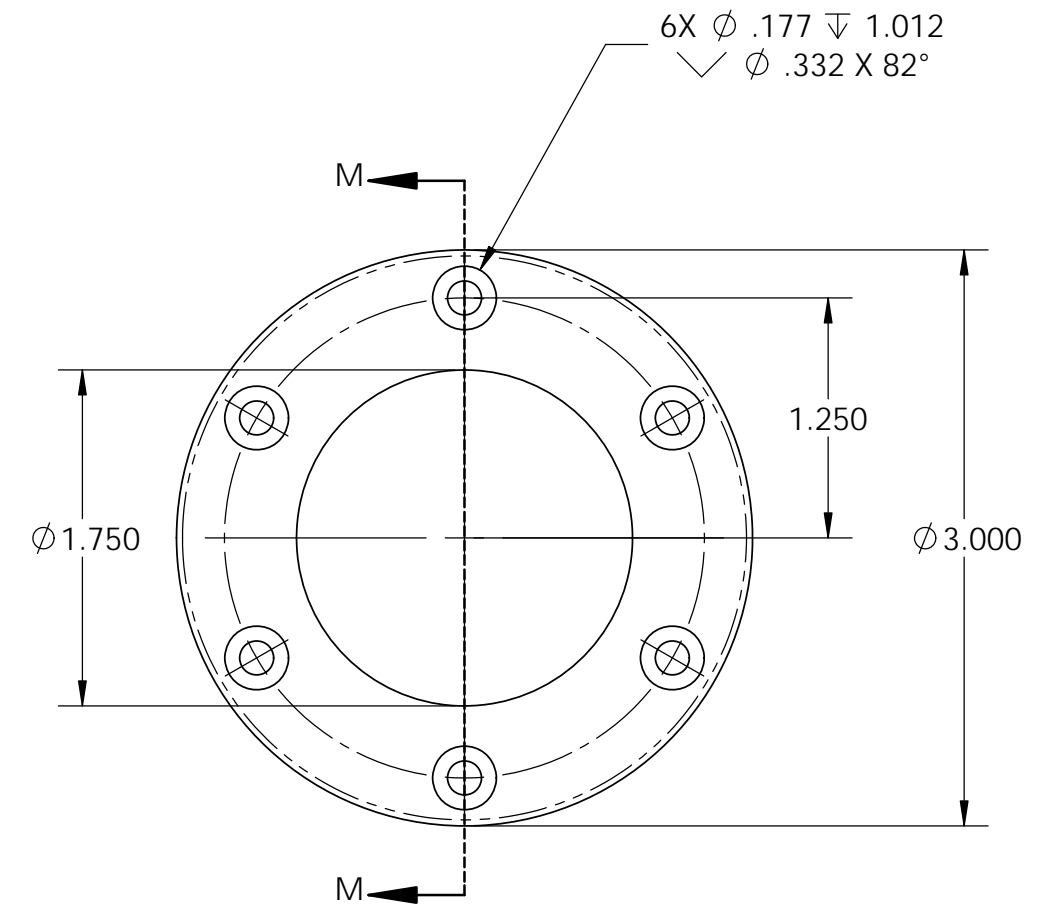

USES 6 SCREWS PER HINGE
 #8-18 PH FHD ZN SHEET METAL SCREW (.500)

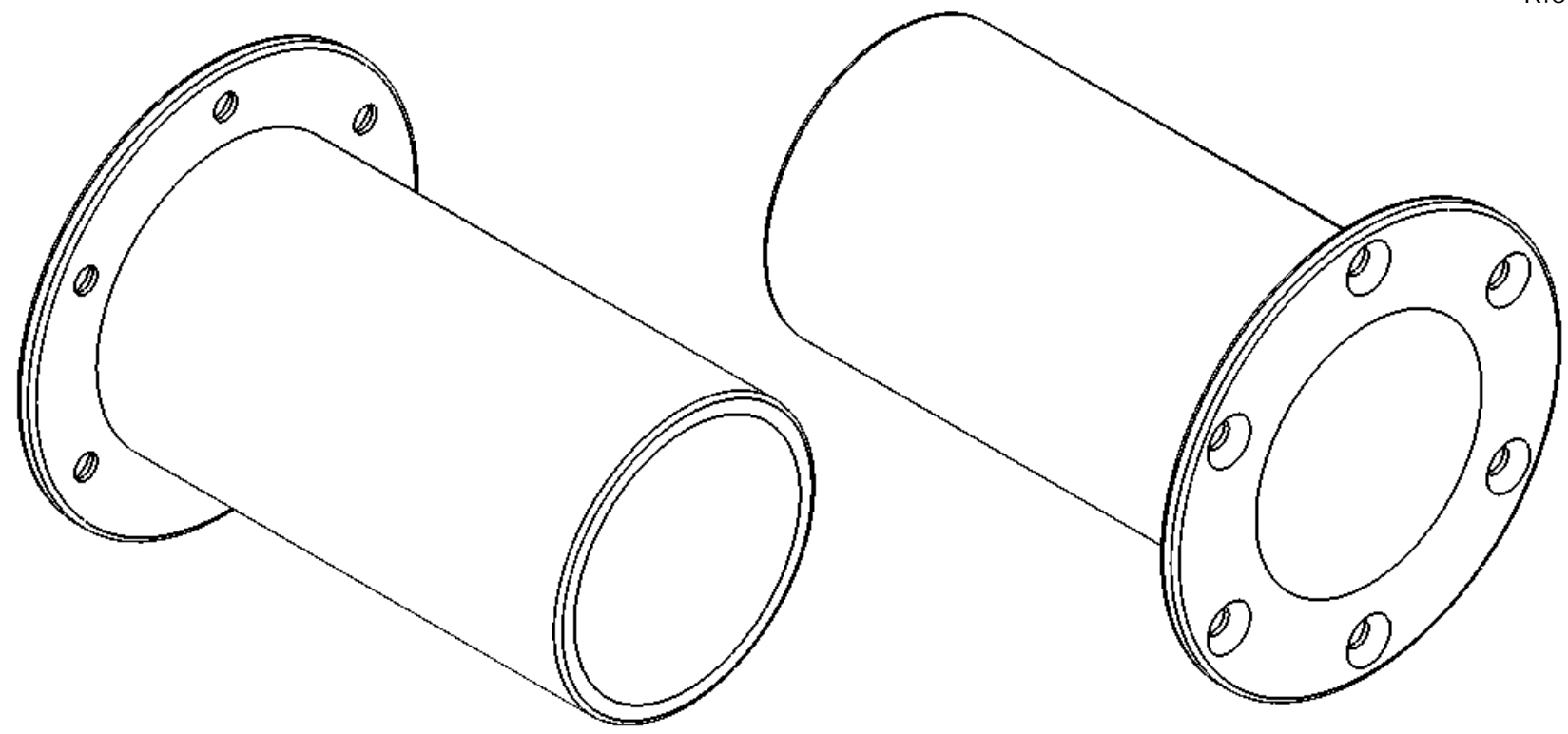

NOT A STOCK PART

UNLESS OTHERWISE SPECIFIED:
 DIMENSIONS ARE IN INCHES
 AND INCLUDE THICKNESS OF PLATING
 TOLERANCES:

BASIC DIMENSIONS	2 PLACE DECIMALS	3 PLACE DECIMALS
UP TO 6	\pm .02	\pm .005
6 TO 24	\pm .03	\pm .010
ABOVE 24	\pm .06	\pm .015

ANGULAR DIMENSIONS \pm 0.5°
 MATERIAL:
 STEEL
 FINISH:
 POLISHED

NAME	DATE
DESIGN BY	
DRAWN BY	DBC 05/03/14
CHECKED BY	
APPROVED BY	

PROPRIETARY AND CONFIDENTIAL

THE INFORMATION CONTAINED IN THIS DRAWING IS THE PROPERTY OF DONALD B. CHEKE, SOLE PROPRIETOR OF TEXTUAL CREATIONS. COPYRIGHT 2014.

ANY REPRODUCTION IN PART OR AS A WHOLE WITHOUT THE WRITTEN PERMISSION OF TEXTUAL CREATIONS IS PROHIBITED.

TextualCreations
 MORE THAN JUST WORDS ON PAPER

TITLE:
PLATFORM HINGE

SIZE B	DWG. NO.	REV
SCALE: 1:1	WG:	SHEET 14 OF 32

REVISIONS				
REV.	ZONE	DESCRIPTION	DATE	BY

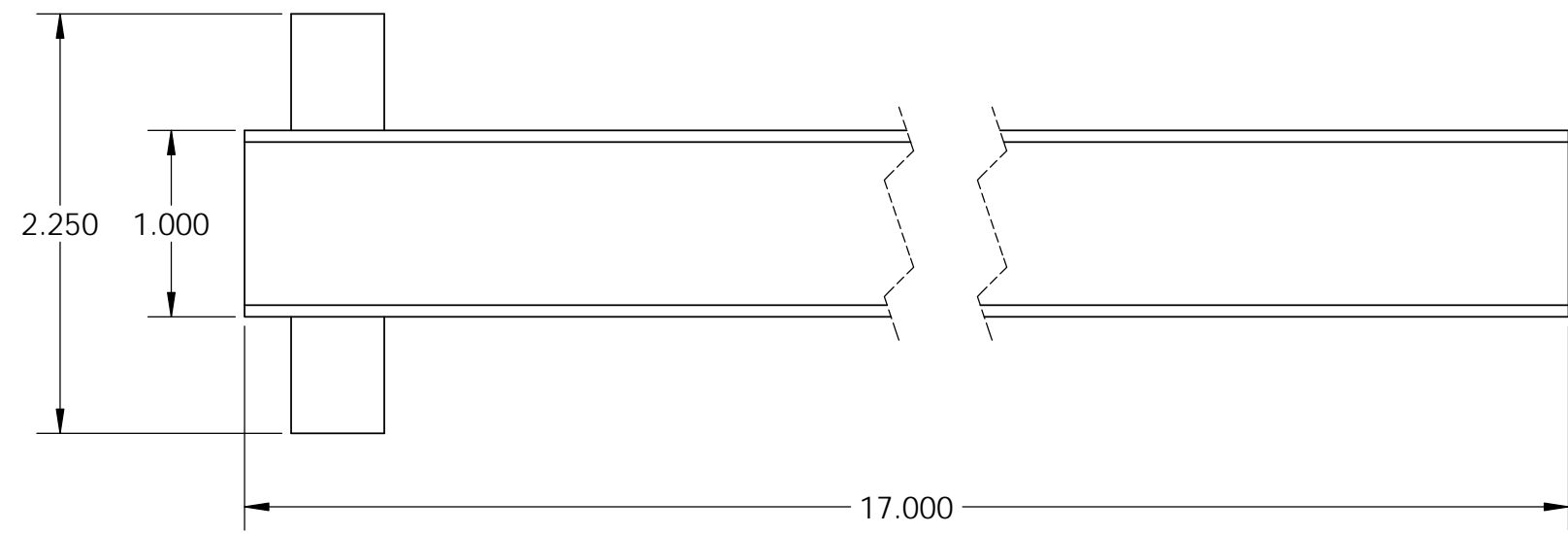
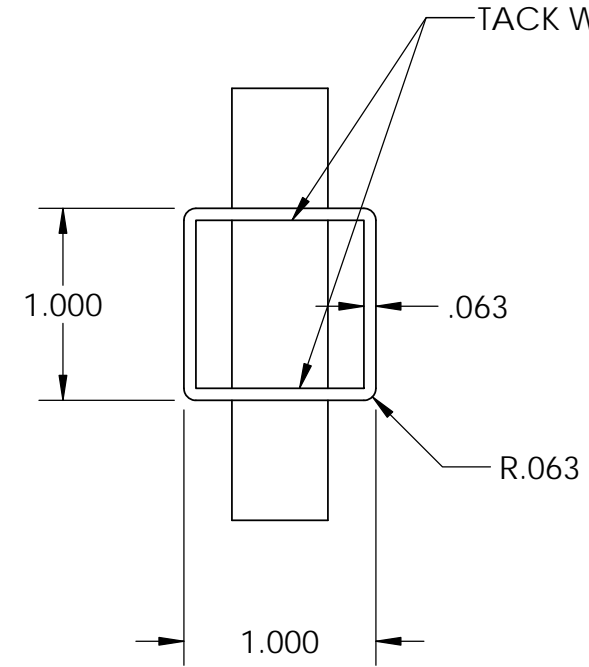
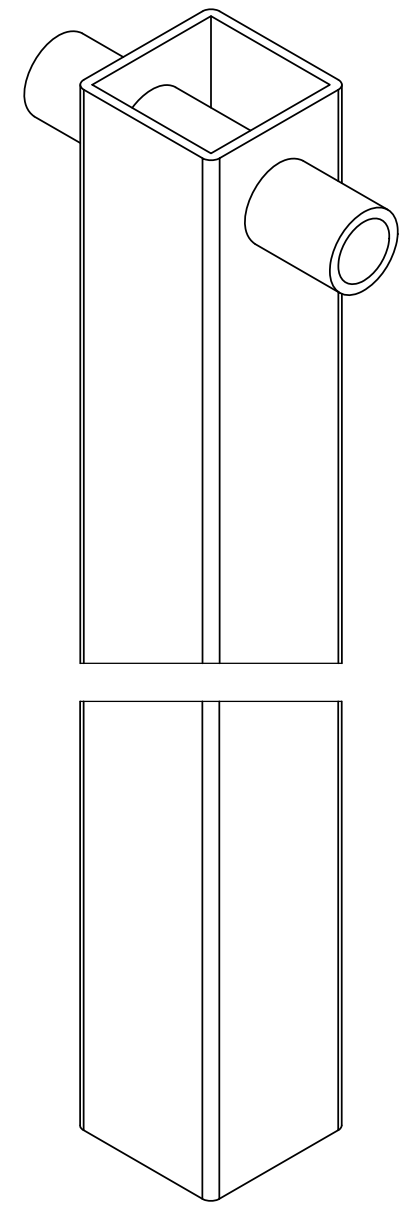
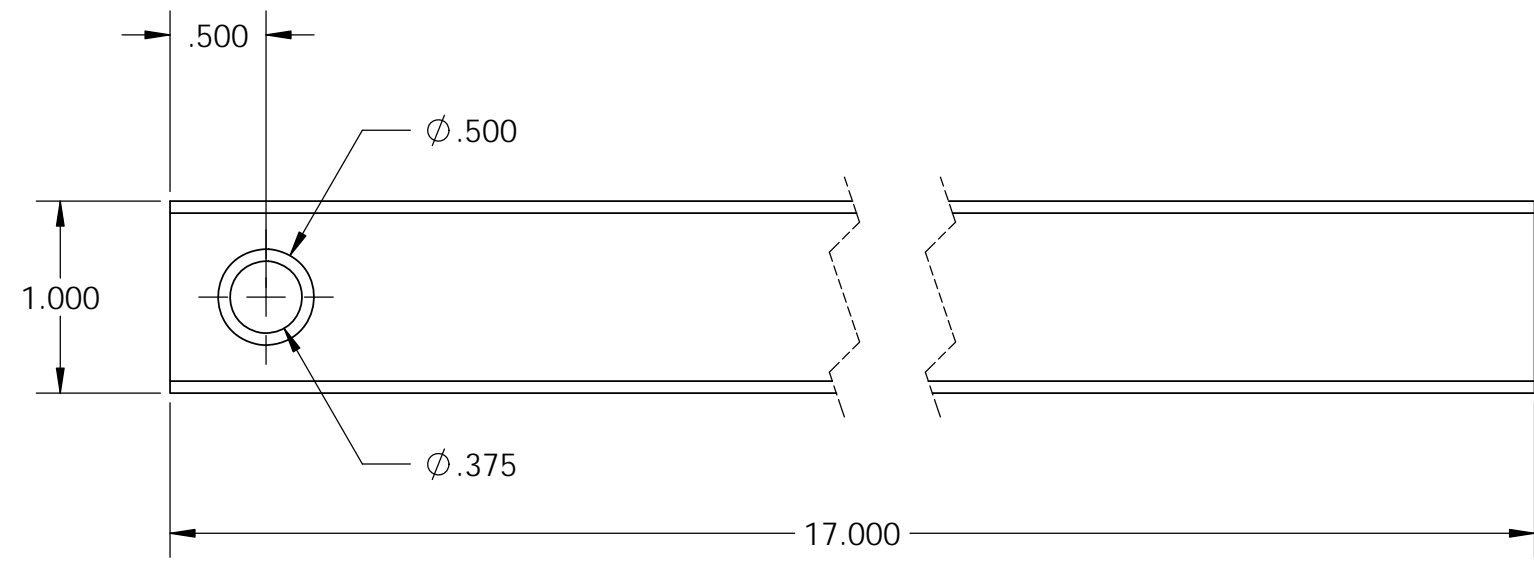

NOT A STOCK PART

UNLESS OTHERWISE SPECIFIED:
DIMENSIONS ARE IN INCHES
AND INCLUDE THICKNESS OF PLATING
TOLERANCES:

BASIC DIMENSIONS	2 PLACE DECIMALS	3 PLACE DECIMALS
UP TO 6	±.02	±.005
6 TO 24	±.03	±.010
ABOVE 24	±.06	±.015

ANGULAR DIMENSIONS ± 0.5°
MATERIAL:
STEEL
FINISH:
PAINTED - MATCH SCHEME

	NAME	DATE
DESIGN BY		
DRAWN BY	DBC	05/03/14
CHECKED BY		
APPROVED BY		

PROPRIETARY AND CONFIDENTIAL
THE INFORMATION CONTAINED IN THIS
DRAWING IS THE PROPERTY OF DONALD B.
CHEKE, SOLE PROPRIETOR OF TEXTUAL
CREATIONS. COPYRIGHT 2014.
ANY REPRODUCTION IN PART OR AS A WHOLE
WITHOUT THE WRITTEN PERMISSION OF
TEXTUAL CREATIONS IS PROHIBITED.

TextualCreations
MORE THAN JUST WORDS ON PAPER

TITLE:
PLATFORM LEG

SIZE B	DWG. NO.	REV
SCALE: 1:1	WG:	SHEET 15 OF 32

REVISIONS				
REV.	ZONE	DESCRIPTION	DATE	BY

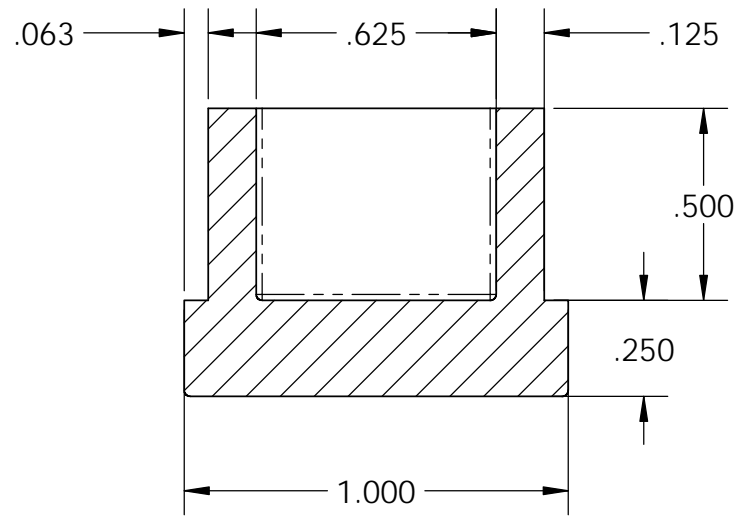
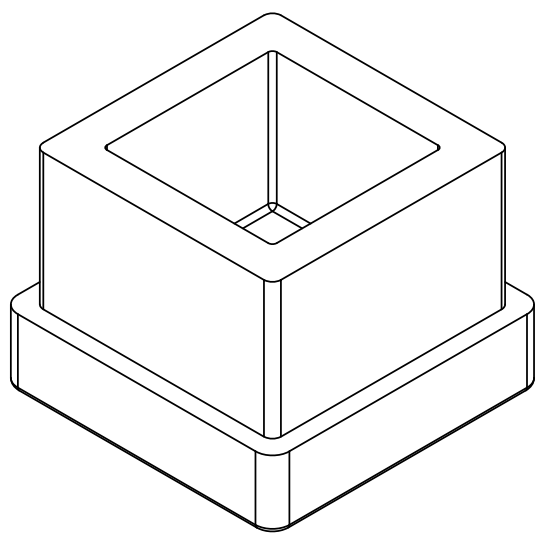
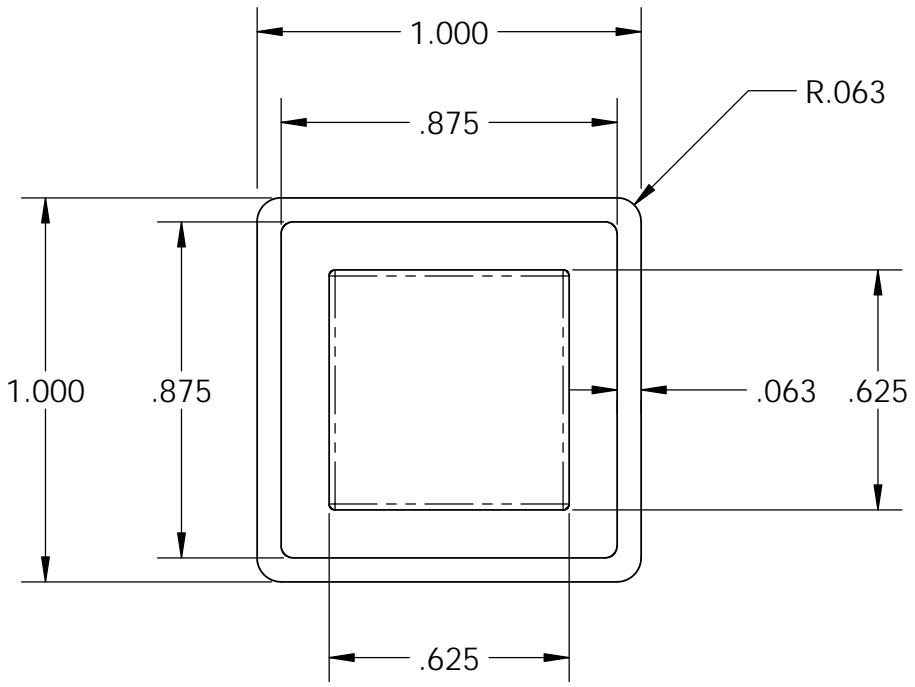

SECTION N-N

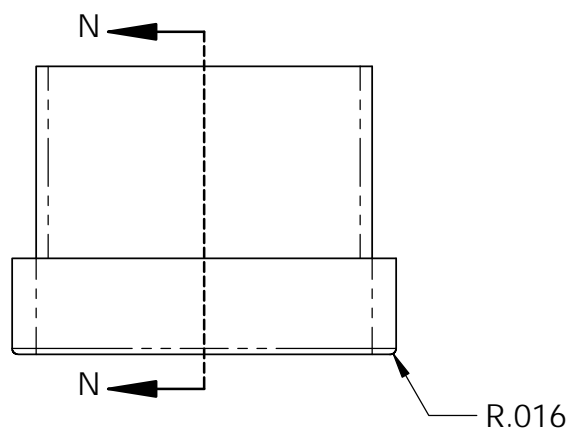

NOT A STOCK PART

UNLESS OTHERWISE SPECIFIED:
DIMENSIONS ARE IN INCHES
AND INCLUDE THICKNESS OF PLATING
TOLERANCES:

BASIC DIMENSIONS	2 PLACE DECIMALS	3 PLACE DECIMALS
UP TO 6	±.02	±.005
6 TO 24	±.03	±.010
ABOVE 24	±.06	±.015

ANGULAR DIMENSIONS ± 0.5°
MATERIAL:
RIGID PVC
FINISH:
GRAY OR BLACK

	NAME	DATE
DESIGN BY		
DRAWN BY	DBC	05/03/14
CHECKED BY		
APPROVED BY		

PROPRIETARY AND CONFIDENTIAL
THE INFORMATION CONTAINED IN THIS DRAWING IS THE PROPERTY OF DONALD B. CHEKE, SOLE PROPRIETOR OF TEXTUAL CREATIONS. COPYRIGHT 2014.
ANY REPRODUCTION IN PART OR AS A WHOLE WITHOUT THE WRITTEN PERMISSION OF TEXTUAL CREATIONS IS PROHIBITED.

TextualCreations
MORE THAN JUST WORDS ON PAPER

TITLE:
PLATFORM FOOT FOR LEG

SIZE B	DWG. NO.	REV
SCALE: 2:1	WG:	SHEET 16 OF 32

8 7 6 5 4 3 2 1

REVISIONS				
REV.	ZONE	DESCRIPTION	DATE	BY

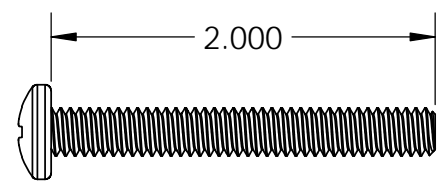
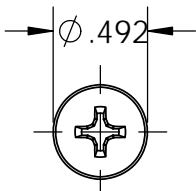
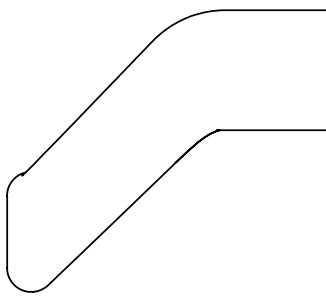
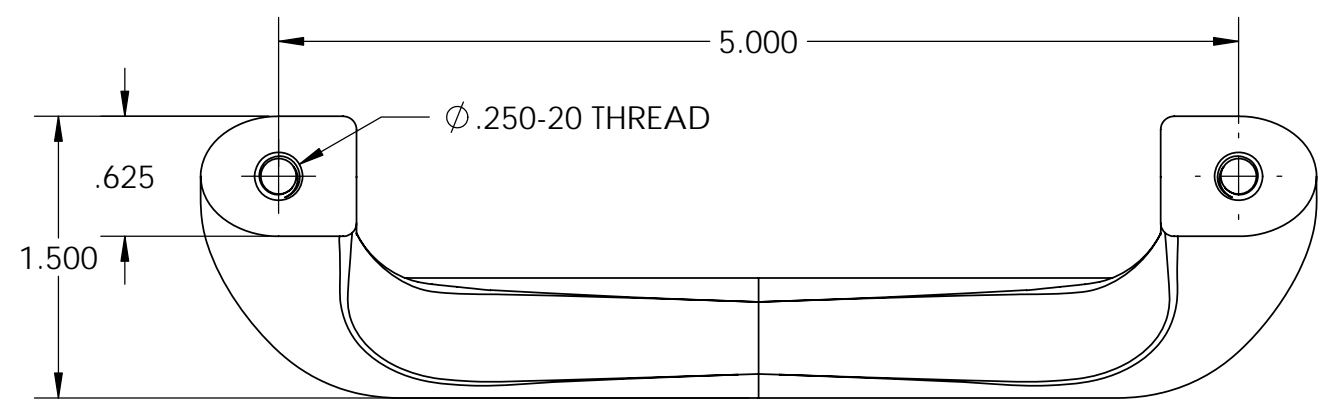
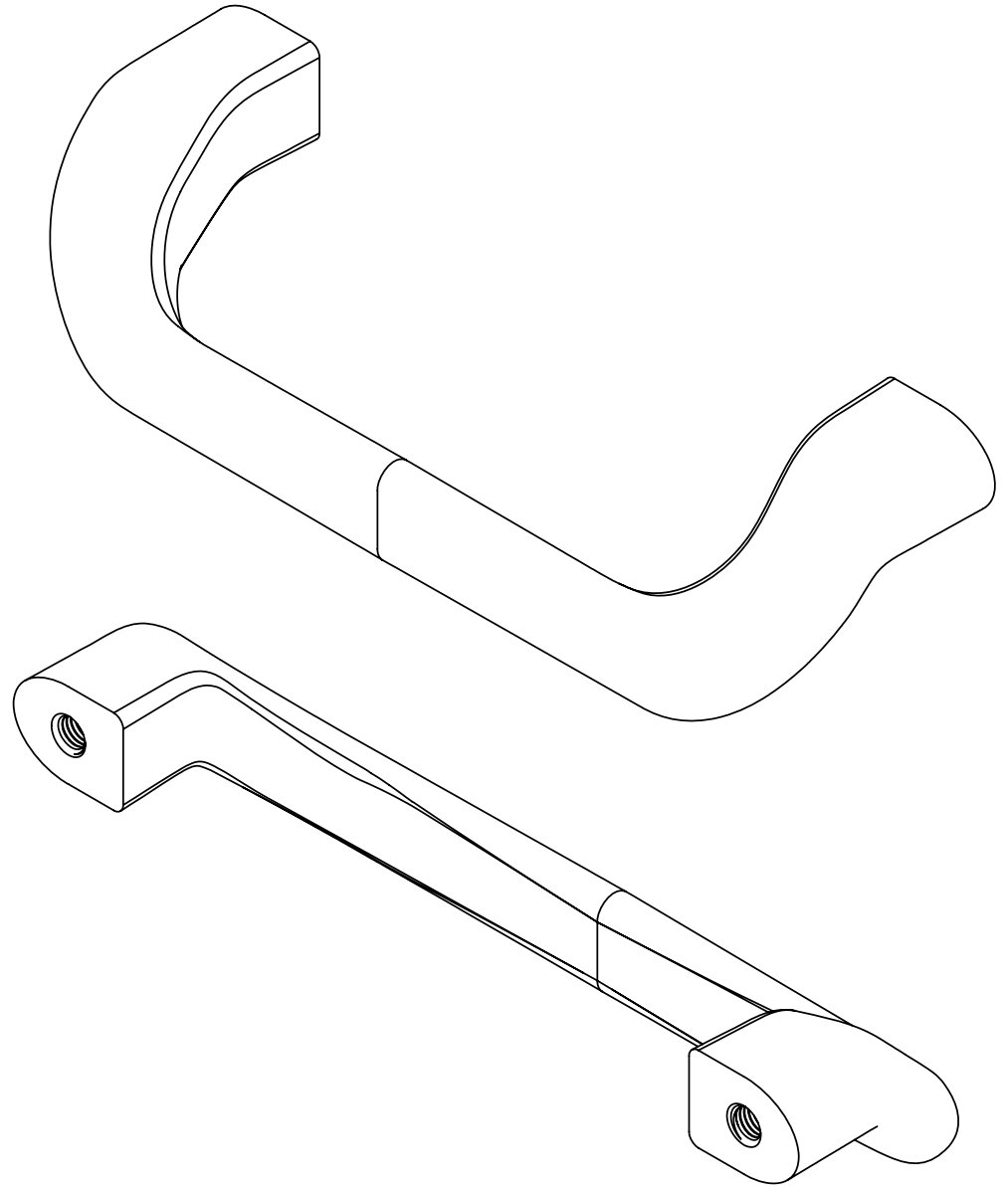
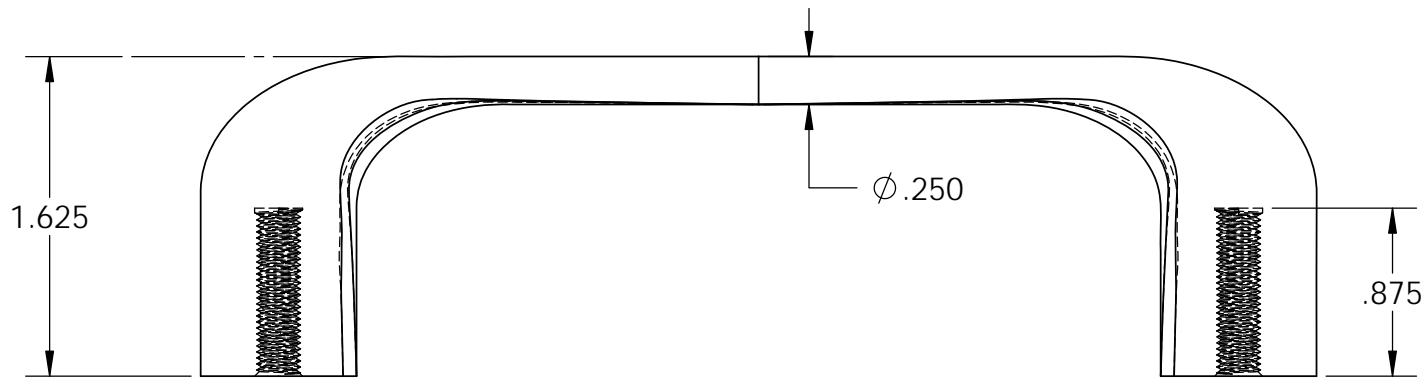

USES 2 SCREWS PER HANDLE
 .25-20 PH PH ZN MACHINE SCREW (2.000)

UNLESS OTHERWISE SPECIFIED:
 DIMENSIONS ARE IN INCHES
 AND INCLUDE THICKNESS OF PLATING

TOLERANCES ON:

BASIC DIMENSIONS	2 PLACE DECIMALS	3 PLACE DECIMALS
UP TO 6	$\pm .02$	$\pm .005$
6 TO 24	$\pm .03$	$\pm .010$
ABOVE 24	$\pm .06$	$\pm .015$

ANGULAR DIMENSIONS $\pm 0.5^\circ$

MATERIAL:
STEEL

FINISH:
POLISHED

	NAME	DATE
DESIGN BY		
DRAWN BY	DBC	05/03/14
CHECKED BY		
APPROVED BY		

PROPRIETARY AND CONFIDENTIAL

THE INFORMATION CONTAINED IN THIS DRAWING IS THE PROPERTY OF DONALD B. CHEKE, SOLE PROPRIETOR OF TEXTUAL CREATIONS. COPYRIGHT 2014.

ANY REPRODUCTION IN PART OR AS A WHOLE WITHOUT THE WRITTEN PERMISSION OF TEXTUAL CREATIONS IS PROHIBITED.

TextualCreations
 MORE THAN JUST WORDS ON PAPER

TITLE:
PLATFORM PULL

SIZE B	DWG. NO.	REV
SCALE: 1:1	WG:	SHEET 17 OF 32

D
C
B
A

D
C
B
A

8 7 6 5 4 3 2 1

8 7 6 5 4 3 2 1

REVISIONS				
REV.	ZONE	DESCRIPTION	DATE	BY

D

D

C

C

B

B

A

A

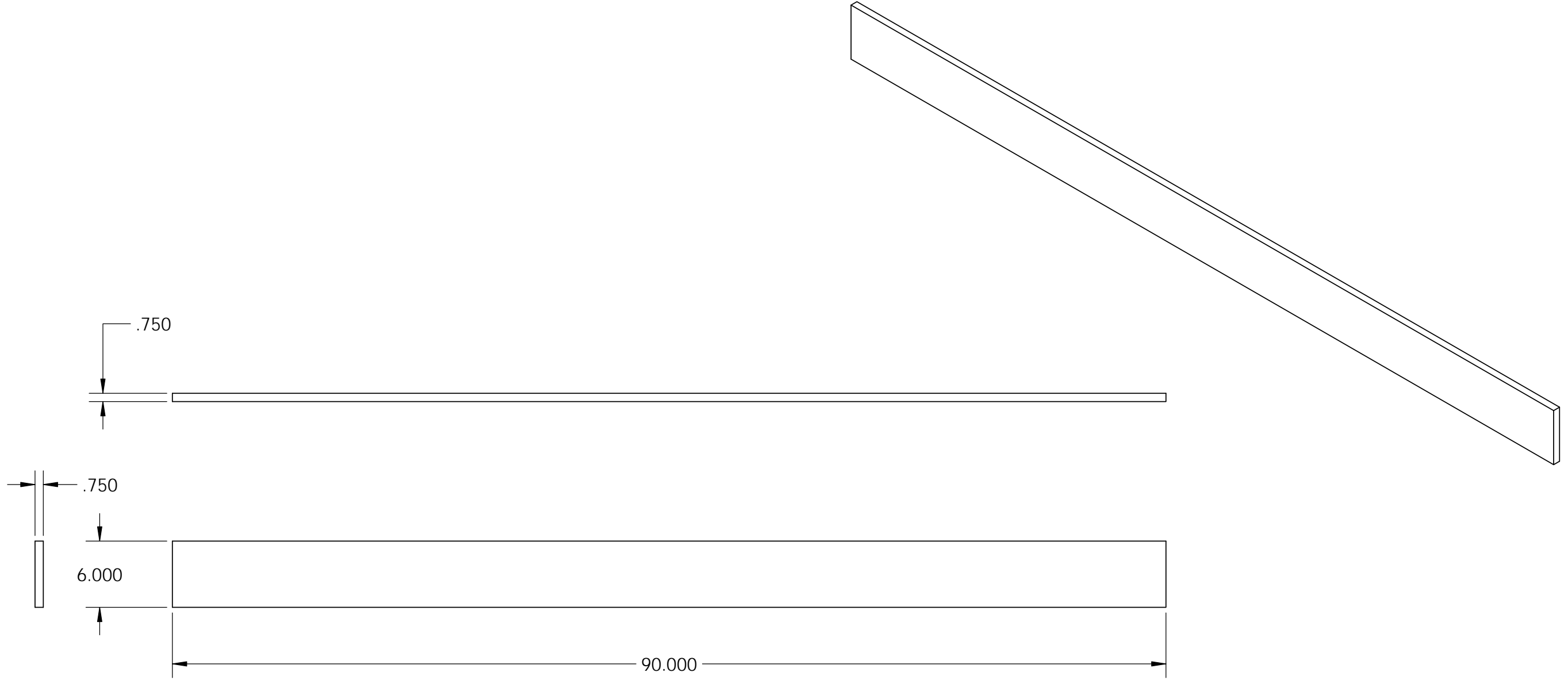

UNLESS OTHERWISE SPECIFIED:
DIMENSIONS ARE IN INCHES
AND INCLUDE THICKNESS OF PLATING
TOLERANCES ON:

BASIC DIMENSIONS	2 PLACE DECIMALS	3 PLACE DECIMALS
UP TO 6	±.02	±.005
6 TO 24	±.03	±.010
ABOVE 24	±.06	±.015

ANGULAR DIMENSIONS ± 0.5°
MATERIAL:
PLYWOOD
FINISH:
STAIN & LACQUER

	NAME	DATE
DESIGN BY		
DRAWN BY	DBC	05/03/14
CHECKED BY		
APPROVED BY		

PROPRIETARY AND CONFIDENTIAL
THE INFORMATION CONTAINED IN THIS DRAWING IS THE PROPERTY OF DONALD B. CHEKE, SOLE PROPRIETOR OF TEXTUAL CREATIONS. COPYRIGHT 2014.
ANY REPRODUCTION IN PART OR AS A WHOLE WITHOUT THE WRITTEN PERMISSION OF TEXTUAL CREATIONS IS PROHIBITED.

TextualCreations
MORE THAN JUST WORDS ON PAPER

TITLE:
**UPRIGHT CASE
BACK FASTEN PANEL**

SIZE	DWG. NO.	REV
B		

SCALE: 1:10 WG: SHEET 18 OF 32

8 7 6 5 4 3 2 1

REVISIONS				
REV.	ZONE	DESCRIPTION	DATE	BY

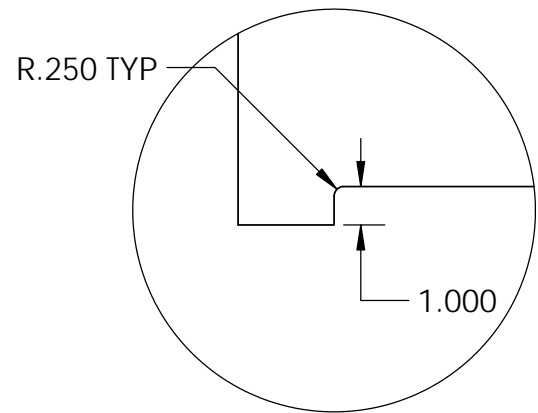

DETAIL 0
SCALE 1 : 5

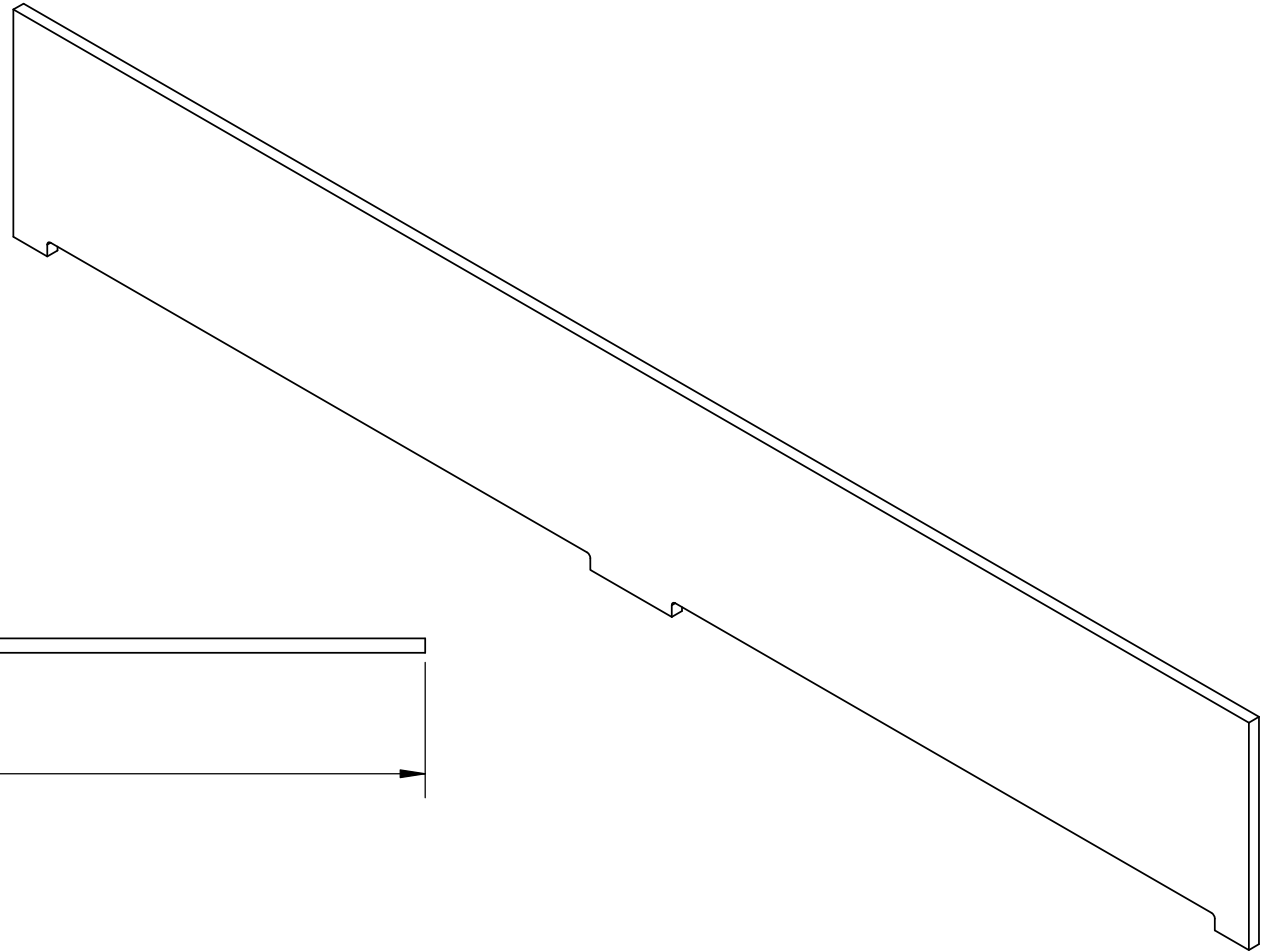
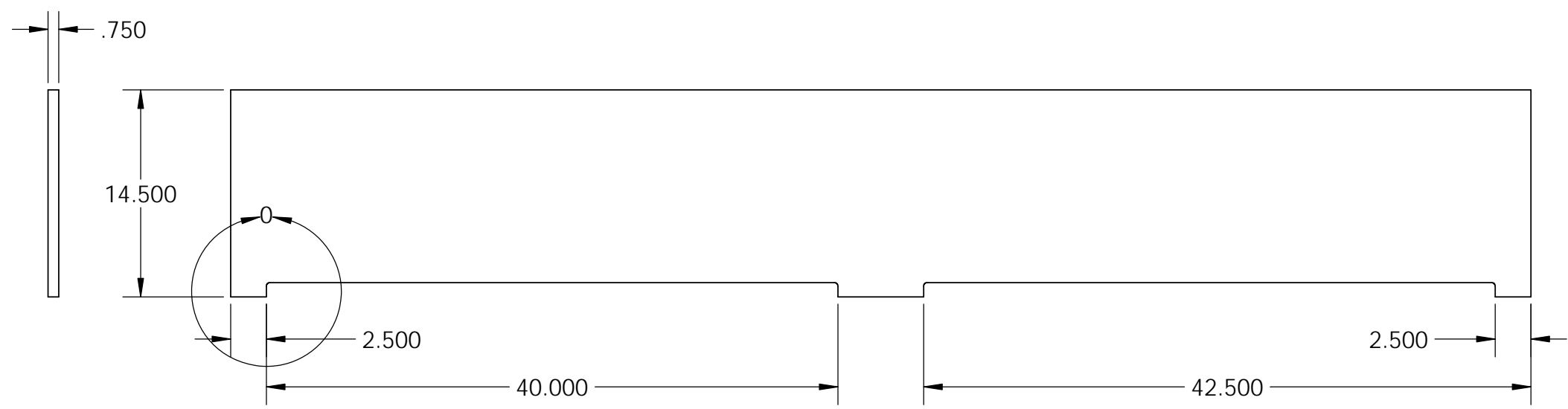
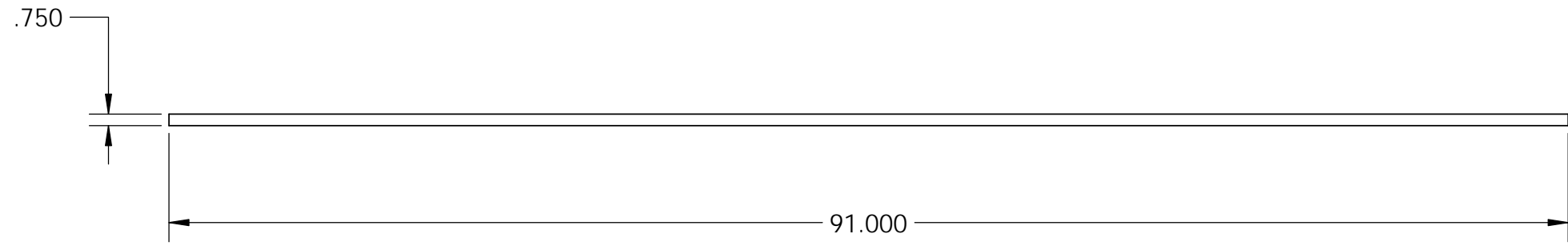

UNLESS OTHERWISE SPECIFIED:
DIMENSIONS ARE IN INCHES
AND INCLUDE THICKNESS OF PLATING
TOLERANCES:

BASIC DIMENSIONS	2 PLACE DECIMALS	3 PLACE DECIMALS
UP TO 6	±.02	±.005
6 TO 24	±.03	±.010
ABOVE 24	±.06	±.015

ANGULAR DIMENSIONS ± 0.5°
MATERIAL:
PLYWOOD
FINISH:
STAIN & LACQUER

	NAME	DATE
DESIGN BY		
DRAWN BY	DBC	05/03/14
CHECKED BY		
APPROVED BY		

PROPRIETARY AND CONFIDENTIAL

THE INFORMATION CONTAINED IN THIS DRAWING IS THE PROPERTY OF DONALD B. CHEKE, SOLE PROPRIETOR OF TEXTUAL CREATIONS. COPYRIGHT 2014.

ANY REPRODUCTION IN PART OR AS A WHOLE WITHOUT THE WRITTEN PERMISSION OF TEXTUAL CREATIONS IS PROHIBITED.

TextualCreations
MORE THAN JUST WORDS ON PAPER

TITLE:
**UPRIGHT CASE
LOWER FRONT PANEL**

SIZE	DWG. NO.	REV
B		

SCALE: 1:10 WG: SHEET 19 OF 32

REVISIONS				
REV.	ZONE	DESCRIPTION	DATE	BY

LEFT SIDE ILLUSTRATED, RIGHT SIDE IS MIRROR COPY OF LEFT

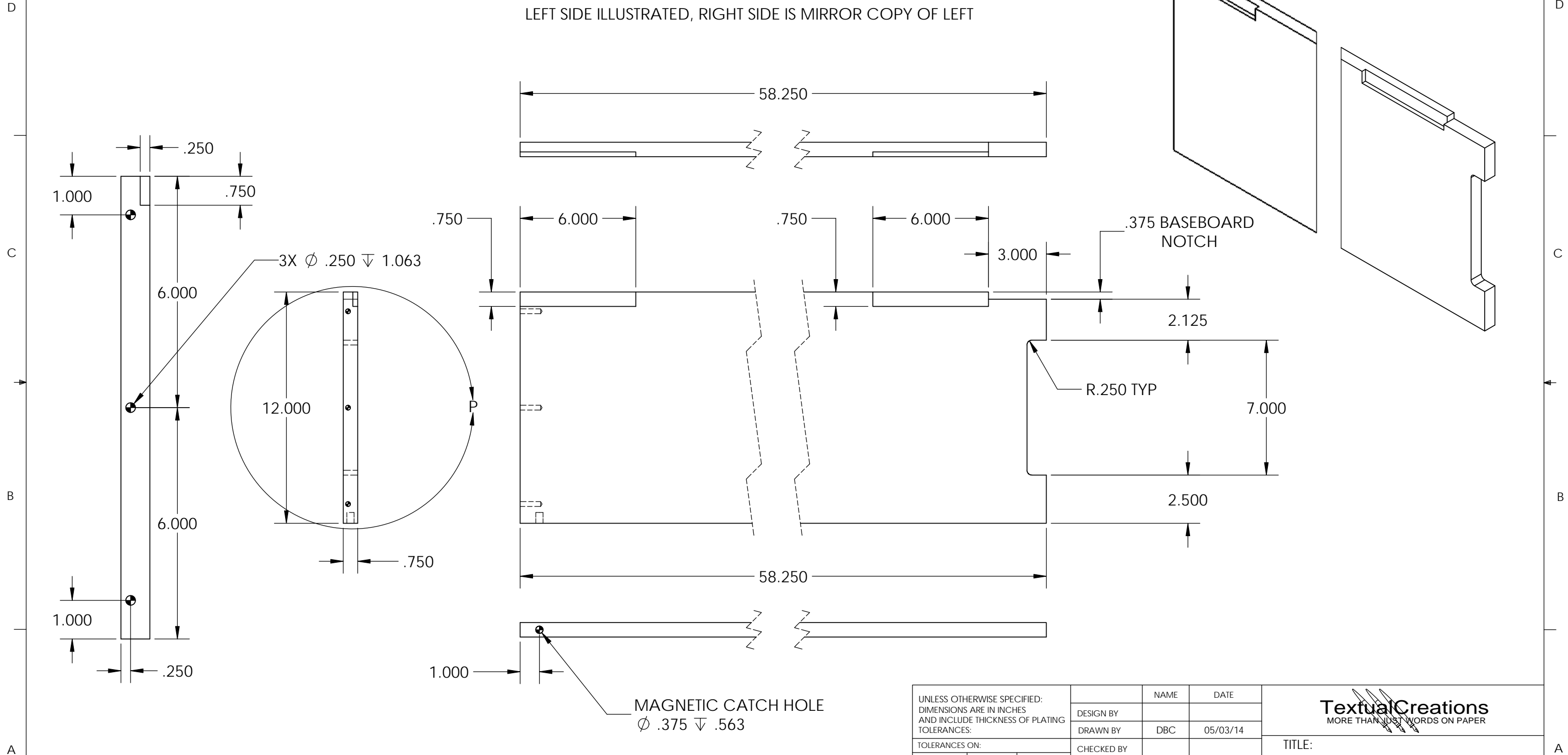

DETAIL P
SCALE 2 : 5

MAGNETIC CATCH HOLE
Ø .375 ∇ .563

UNLESS OTHERWISE SPECIFIED:
DIMENSIONS ARE IN INCHES
AND INCLUDE THICKNESS OF PLATING
TOLERANCES:

BASIC DIMENSIONS	2 PLACE DECIMALS	3 PLACE DECIMALS
UP TO 6	±.02	±.005
6 TO 24	±.03	±.010
ABOVE 24	±.06	±.015

ANGULAR DIMENSIONS ± 0.5°
MATERIAL:
PLYWOOD
FINISH:
STAIN & LACQUER

NAME	DATE
DESIGN BY	
DRAWN BY	DBC 05/03/14
CHECKED BY	
APPROVED BY	

PROPRIETARY AND CONFIDENTIAL
THE INFORMATION CONTAINED IN THIS DRAWING IS THE PROPERTY OF DONALD B. CHEKE, SOLE PROPRIETOR OF TEXTUAL CREATIONS. COPYRIGHT 2014.
ANY REPRODUCTION IN PART OR AS A WHOLE WITHOUT THE WRITTEN PERMISSION OF TEXTUAL CREATIONS IS PROHIBITED.

TextualCreations
MORE THAN JUST WORDS ON PAPER

TITLE:
**UPRIGHT CASE
OUTSIDE SIDE PANEL**

SIZE B	DWG. NO.	REV
SCALE: 1:5	WG:	SHEET 20 OF 32

REVISIONS				
REV.	ZONE	DESCRIPTION	DATE	BY

LEFT AND RIGHT SIDE ARE IDENTICAL

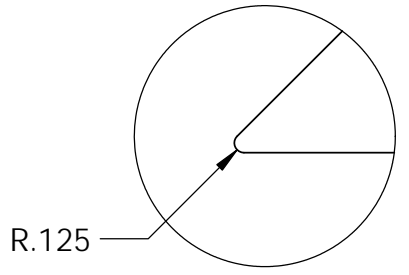

DETAIL Q
SCALE 2 : 5

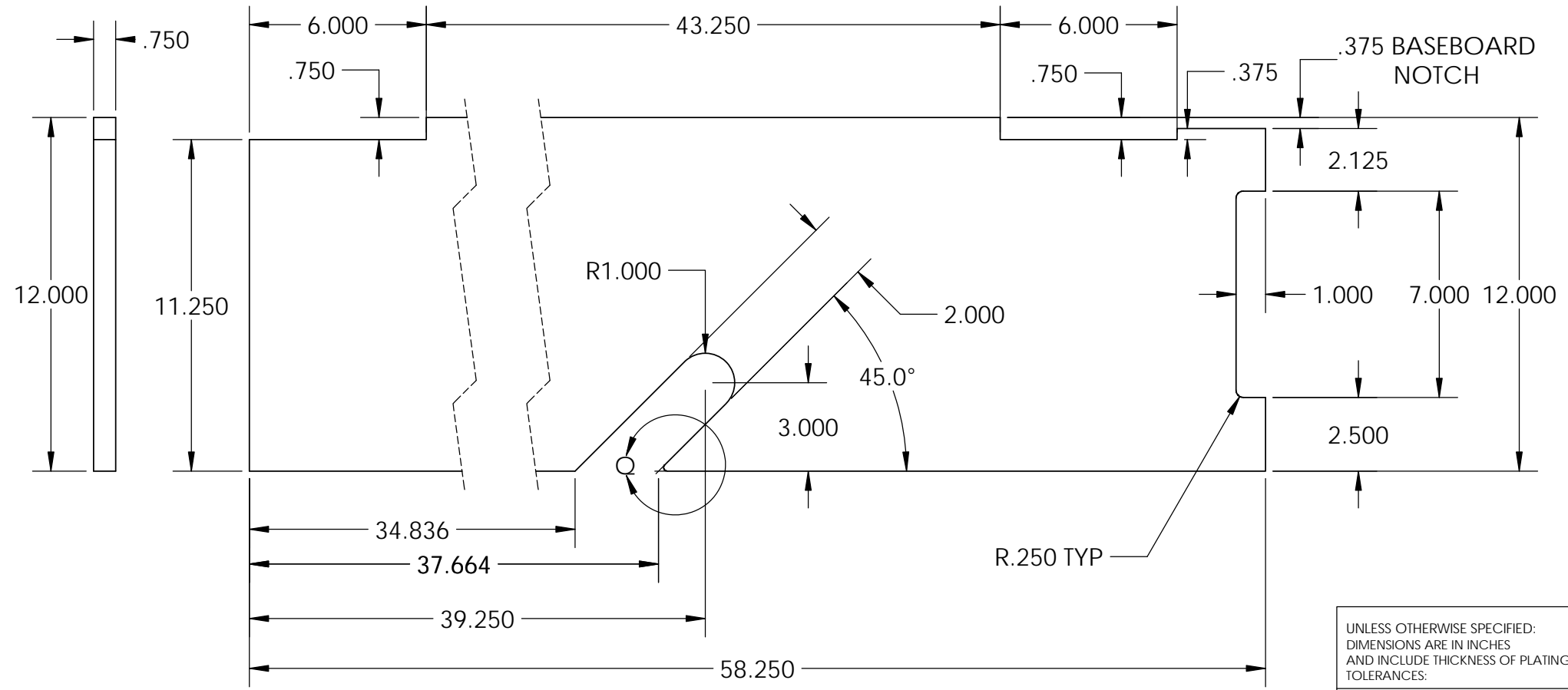
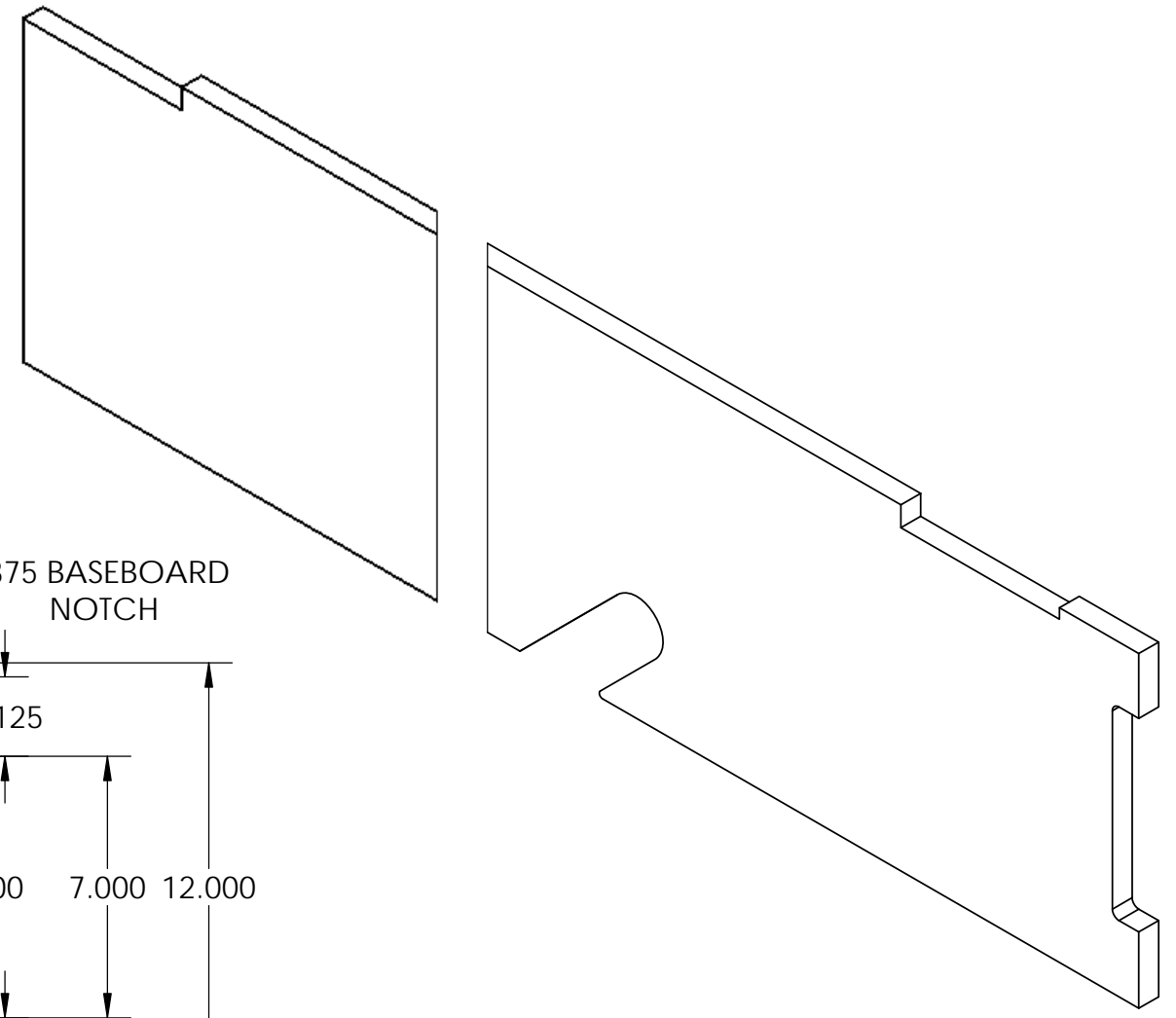
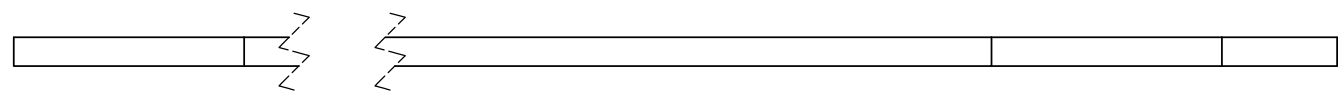

UNLESS OTHERWISE SPECIFIED:
DIMENSIONS ARE IN INCHES
AND INCLUDE THICKNESS OF PLATING

TOLERANCES ON:

BASIC DIMENSIONS	2 PLACE DECIMALS	3 PLACE DECIMALS
UP TO 6	±.02	±.005
6 TO 24	±.03	±.010
ABOVE 24	±.06	±.015

ANGULAR DIMENSIONS ± 0.5°

MATERIAL:
PLYWOOD

FINISH:
STAIN & LACQUER

DESIGN BY	NAME	DATE
DRAWN BY	DBC	05/03/14
CHECKED BY		
APPROVED BY		

PROPRIETARY AND CONFIDENTIAL

THE INFORMATION CONTAINED IN THIS DRAWING IS THE PROPERTY OF DONALD B. CHEKE, SOLE PROPRIETOR OF TEXTUAL CREATIONS. COPYRIGHT 2014.

ANY REPRODUCTION IN PART OR AS A WHOLE WITHOUT THE WRITTEN PERMISSION OF TEXTUAL CREATIONS IS PROHIBITED.

TextualCreations
MORE THAN JUST WORDS ON PAPER

TITLE: UPRIGHT CASE HINGE PANEL		
SIZE B	DWG. NO.	REV
SCALE: 1:5	WG:	SHEET 21 OF 32

8 7 6 5 4 3 2 1

REVISIONS				
REV.	ZONE	DESCRIPTION	DATE	BY

CASE CAP IS ONLY USED IF UPPER CABINET IS NOT SUPPLIED

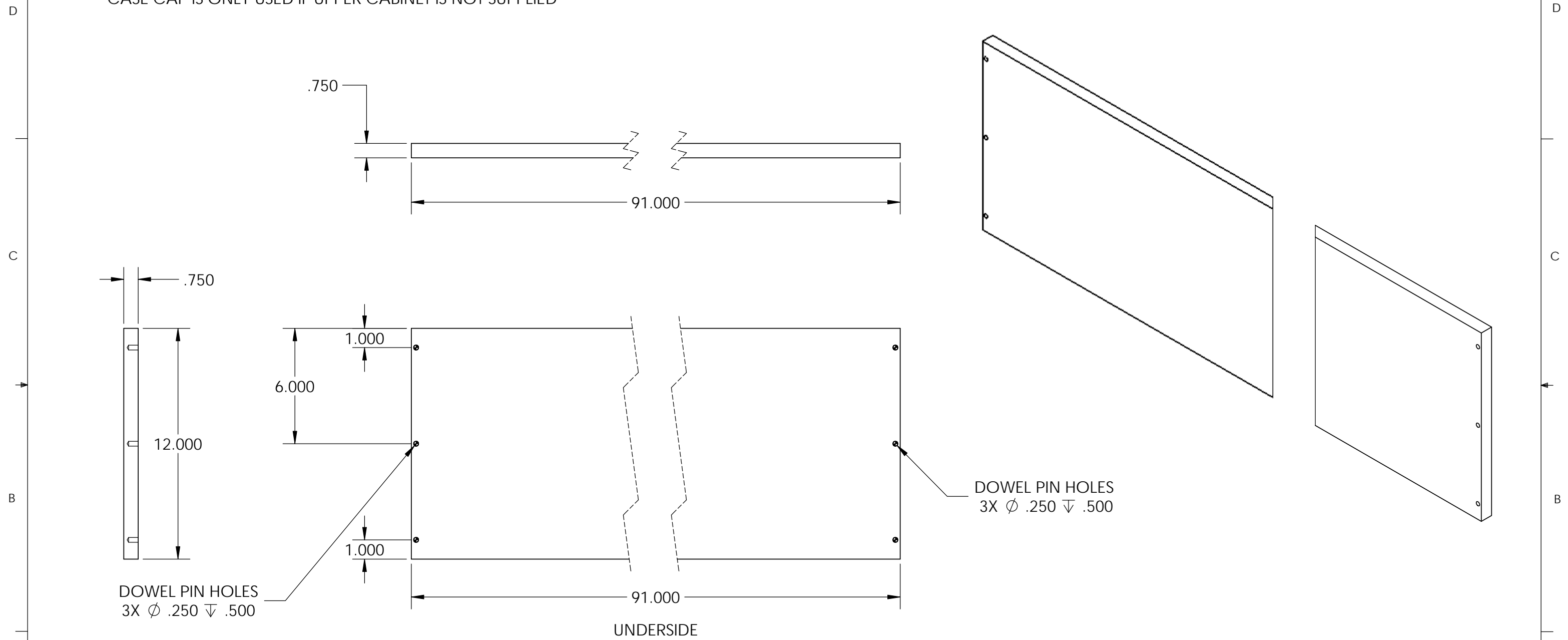

UNLESS OTHERWISE SPECIFIED:
DIMENSIONS ARE IN INCHES
AND INCLUDE THICKNESS OF PLATING
TOLERANCES:

BASIC DIMENSIONS	2 PLACE DECIMALS	3 PLACE DECIMALS
UP TO 6	±.02	±.005
6 TO 24	±.03	±.010
ABOVE 24	±.06	±.015

ANGULAR DIMENSIONS ± 0.5°
MATERIAL:
PLYWOOD
FINISH:
STAIN & LACQUER

	NAME	DATE
DESIGN BY		
DRAWN BY	DBC	05/03/14
CHECKED BY		
APPROVED BY		

PROPRIETARY AND CONFIDENTIAL
THE INFORMATION CONTAINED IN THIS
DRAWING IS THE PROPERTY OF DONALD B.
CHEKE, SOLE PROPRIETOR OF TEXTUAL
CREATIONS. COPYRIGHT 2014.
ANY REPRODUCTION IN PART OR AS A WHOLE
WITHOUT THE WRITTEN PERMISSION OF
TEXTUAL CREATIONS IS PROHIBITED.

TextualCreations
MORE THAN JUST WORDS ON PAPER

TITLE:
UPRIGHT CASE CAP

SIZE B	DWG. NO.	REV
SCALE: 1:5	WG:	SHEET 22 OF 32

8 7 6 5 4 3 2 1

REVISIONS				
REV.	ZONE	DESCRIPTION	DATE	BY

D
C
B
A

D
C
B
A

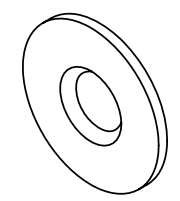
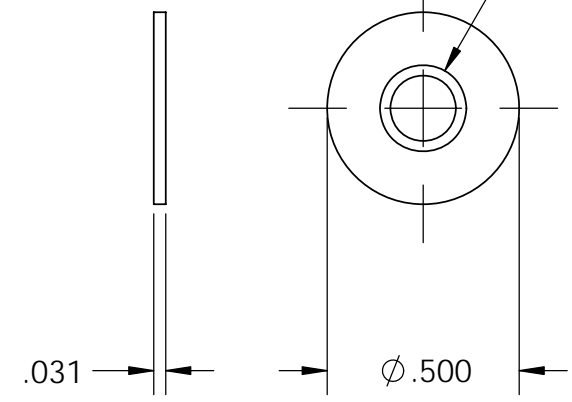
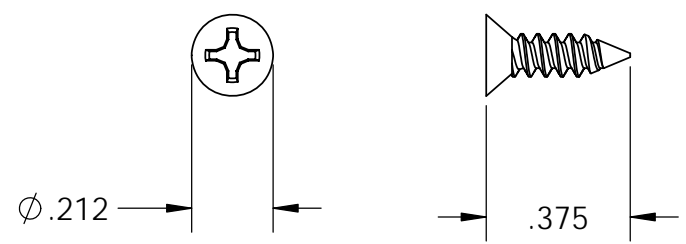

ϕ .129 THRU ALL
 \surd ϕ .225 X 82°

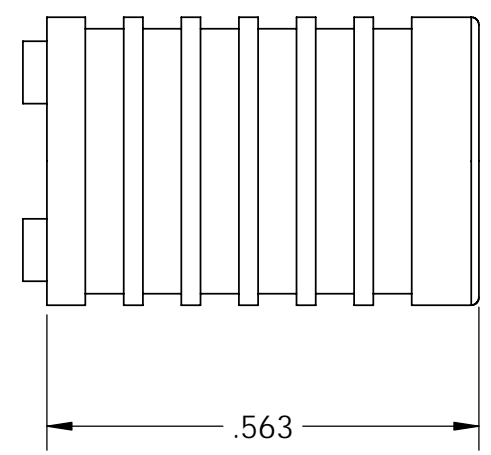
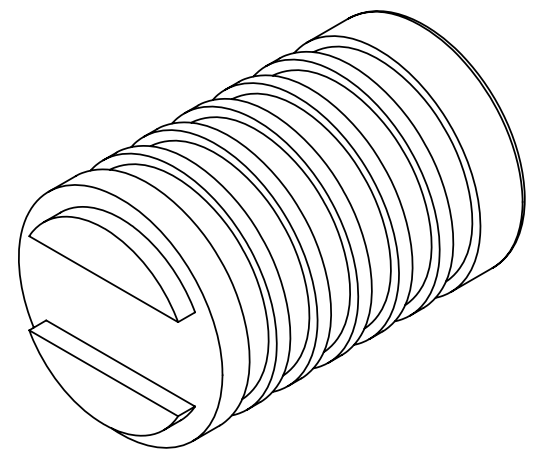
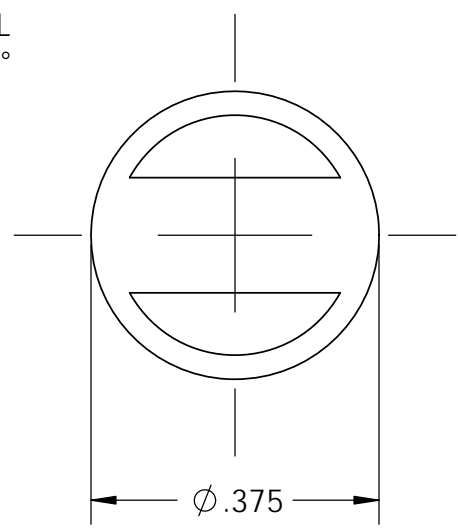

UNLESS OTHERWISE SPECIFIED:
 DIMENSIONS ARE IN INCHES
 AND INCLUDE THICKNESS OF PLATING
 TOLERANCES ON:

BASIC DIMENSIONS	2 PLACE DECIMALS	3 PLACE DECIMALS
UP TO 6	±.02	±.005
6 TO 24	±.03	±.010
ABOVE 24	±.06	±.015

ANGULAR DIMENSIONS ± 0.5°
 MATERIAL:
PLASTIC/METAL
 FINISH:

	NAME	DATE
DESIGN BY		
DRAWN BY	DBC	05/03/14
CHECKED BY		
APPROVED BY		

PROPRIETARY AND CONFIDENTIAL
 THE INFORMATION CONTAINED IN THIS DRAWING IS THE PROPERTY OF DONALD B. CHEKE, SOLE PROPRIETOR OF TEXTUAL CREATIONS. COPYRIGHT 2014.
 ANY REPRODUCTION IN PART OR AS A WHOLE WITHOUT THE WRITTEN PERMISSION OF TEXTUAL CREATIONS IS PROHIBITED.

TextualCreations
 MORE THAN JUST WORDS ON PAPER

TITLE:
**UPRIGHT CASE
 MAGNETIC CATCH**

SIZE B	DWG. NO.	REV
SCALE: 2:1	WG:	SHEET 23 OF 32

8 7 6 5 4 3 2 1

REVISIONS				
REV.	ZONE	DESCRIPTION	DATE	BY

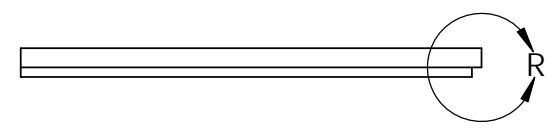

LEFT SIDE ILLUSTRATED, RIGHT SIDE IS MIRROR COPY OF LEFT

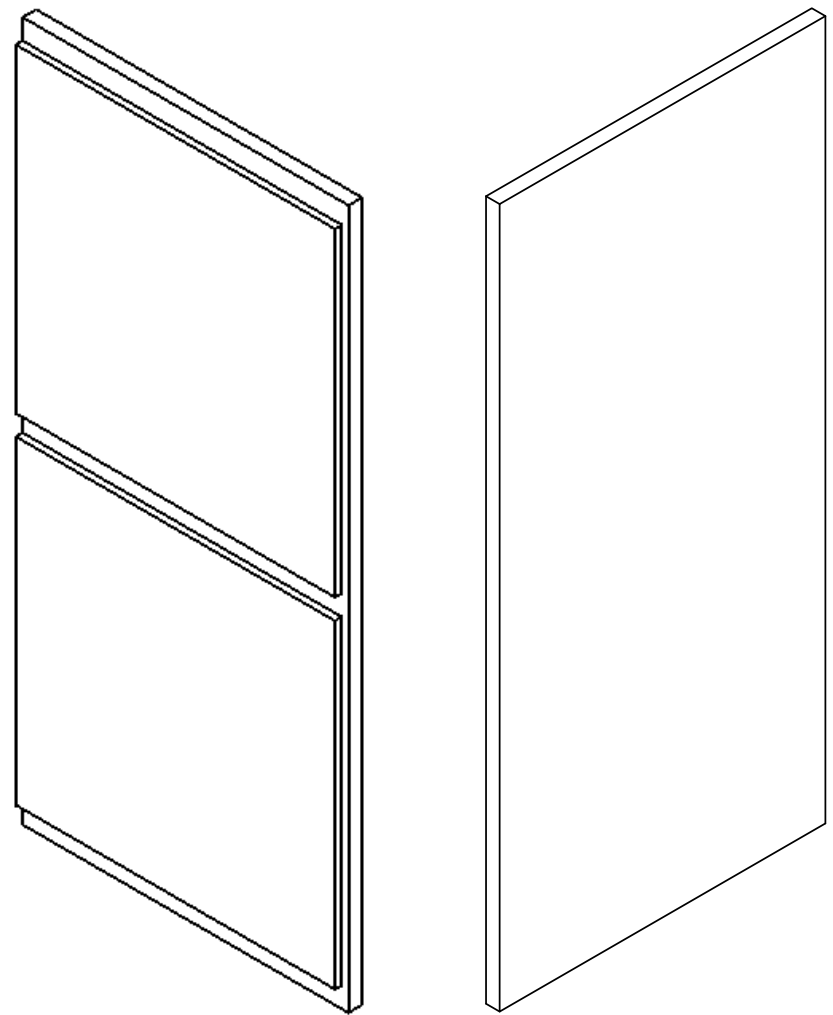
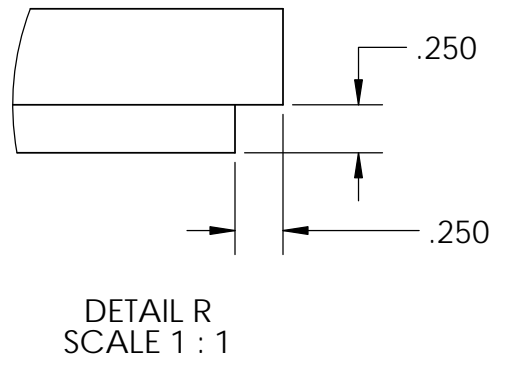
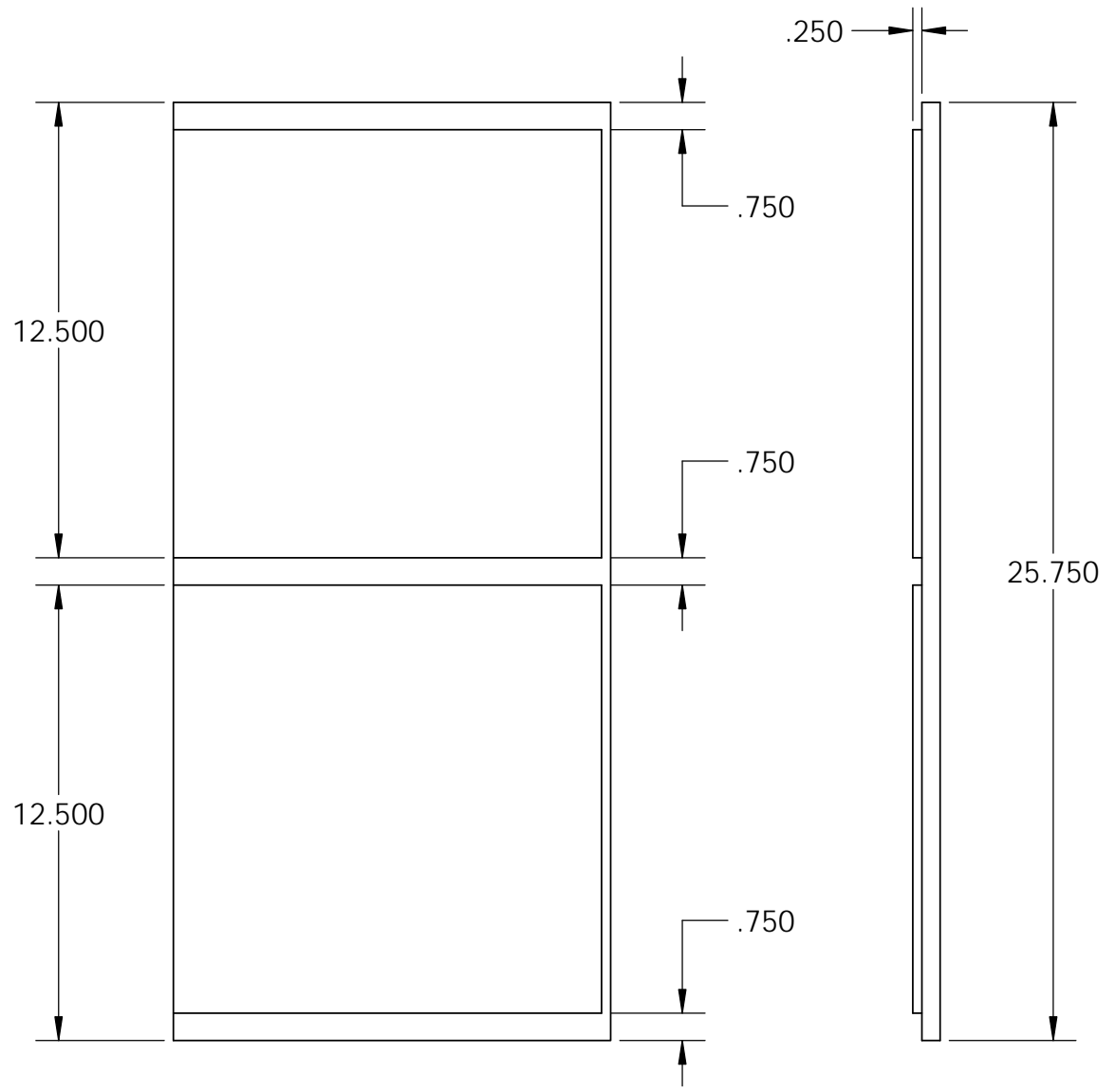

UNLESS OTHERWISE SPECIFIED: DIMENSIONS ARE IN INCHES AND INCLUDE THICKNESS OF PLATING TOLERANCES: TOLERANCES ON: <table border="1"> <tr> <th>BASIC DIMENSIONS</th> <th>2 PLACE DECIMALS</th> <th>3 PLACE DECIMALS</th> </tr> <tr> <td>UP TO 6</td> <td>±.02</td> <td>±.005</td> </tr> <tr> <td>6 TO 24</td> <td>±.03</td> <td>±.010</td> </tr> <tr> <td>ABOVE 24</td> <td>±.06</td> <td>±.015</td> </tr> </table> ANGULAR DIMENSIONS ± 0.5° MATERIAL: PLYWOOD FINISH: STAIN & LACQUER	BASIC DIMENSIONS	2 PLACE DECIMALS	3 PLACE DECIMALS	UP TO 6	±.02	±.005	6 TO 24	±.03	±.010	ABOVE 24	±.06	±.015	NAME	DATE	
	BASIC DIMENSIONS	2 PLACE DECIMALS	3 PLACE DECIMALS												
	UP TO 6	±.02	±.005												
	6 TO 24	±.03	±.010												
ABOVE 24	±.06	±.015													
DESIGN BY															
DRAWN BY	DBC	05/03/14													
CHECKED BY															
APPROVED BY			TITLE: UPPER CABINET SIDE PANEL												
PROPRIETARY AND CONFIDENTIAL THE INFORMATION CONTAINED IN THIS DRAWING IS THE PROPERTY OF DONALD B. CHEKE, SOLE PROPRIETOR OF TEXTUAL CREATIONS. COPYRIGHT 2014. ANY REPRODUCTION IN PART OR AS A WHOLE WITHOUT THE WRITTEN PERMISSION OF TEXTUAL CREATIONS IS PROHIBITED.	SIZE B	DWG. NO.	REV												
	SCALE: 1:5	WG:	SHEET 24 OF 32												

REVISIONS				
REV.	ZONE	DESCRIPTION	DATE	BY

TOP PANEL ILLUSTRATED, BOTTOM PANEL IS MIRROR COPY OF TOP PANEL

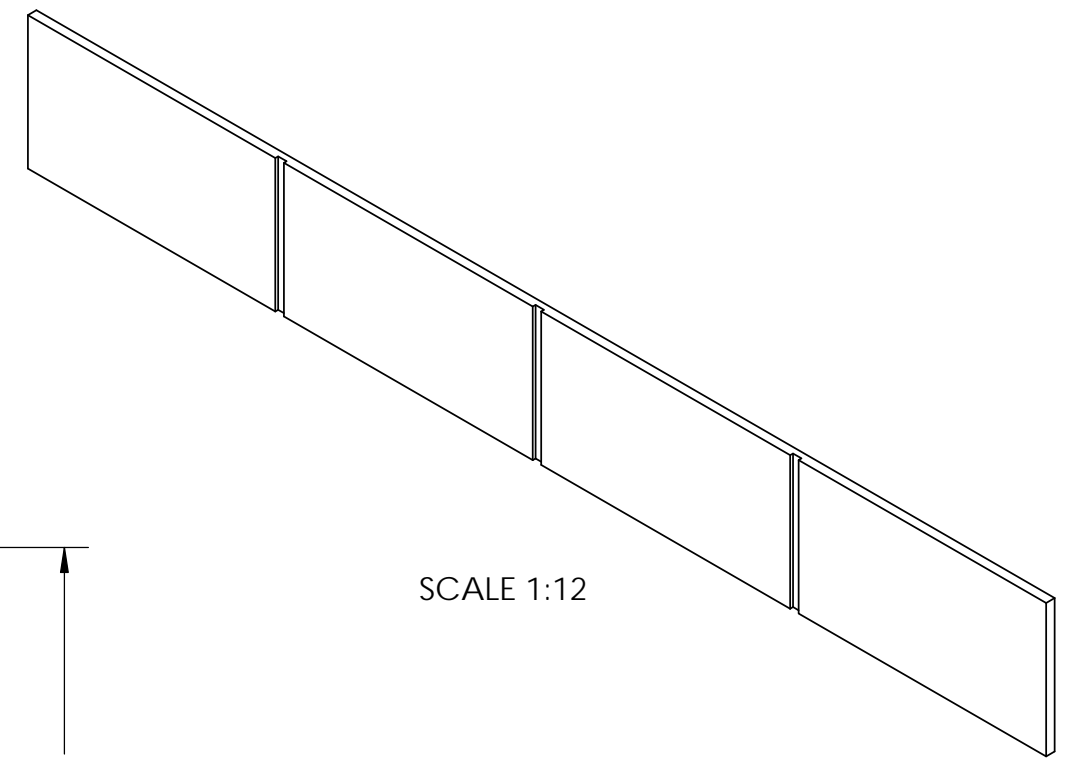
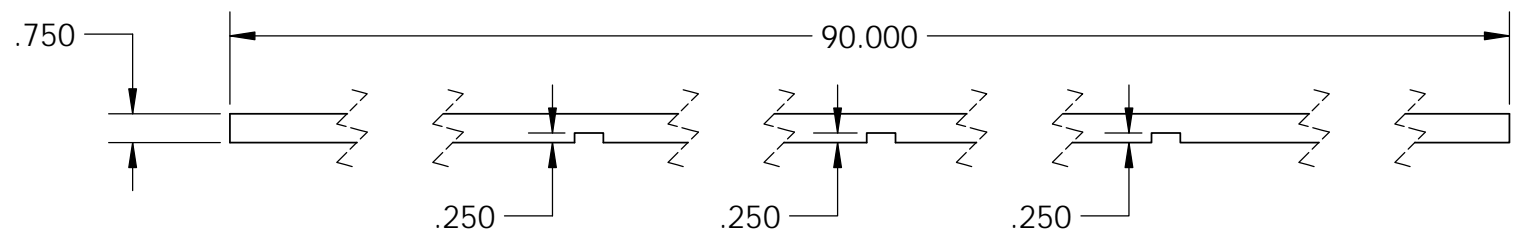

SCALE 1:12

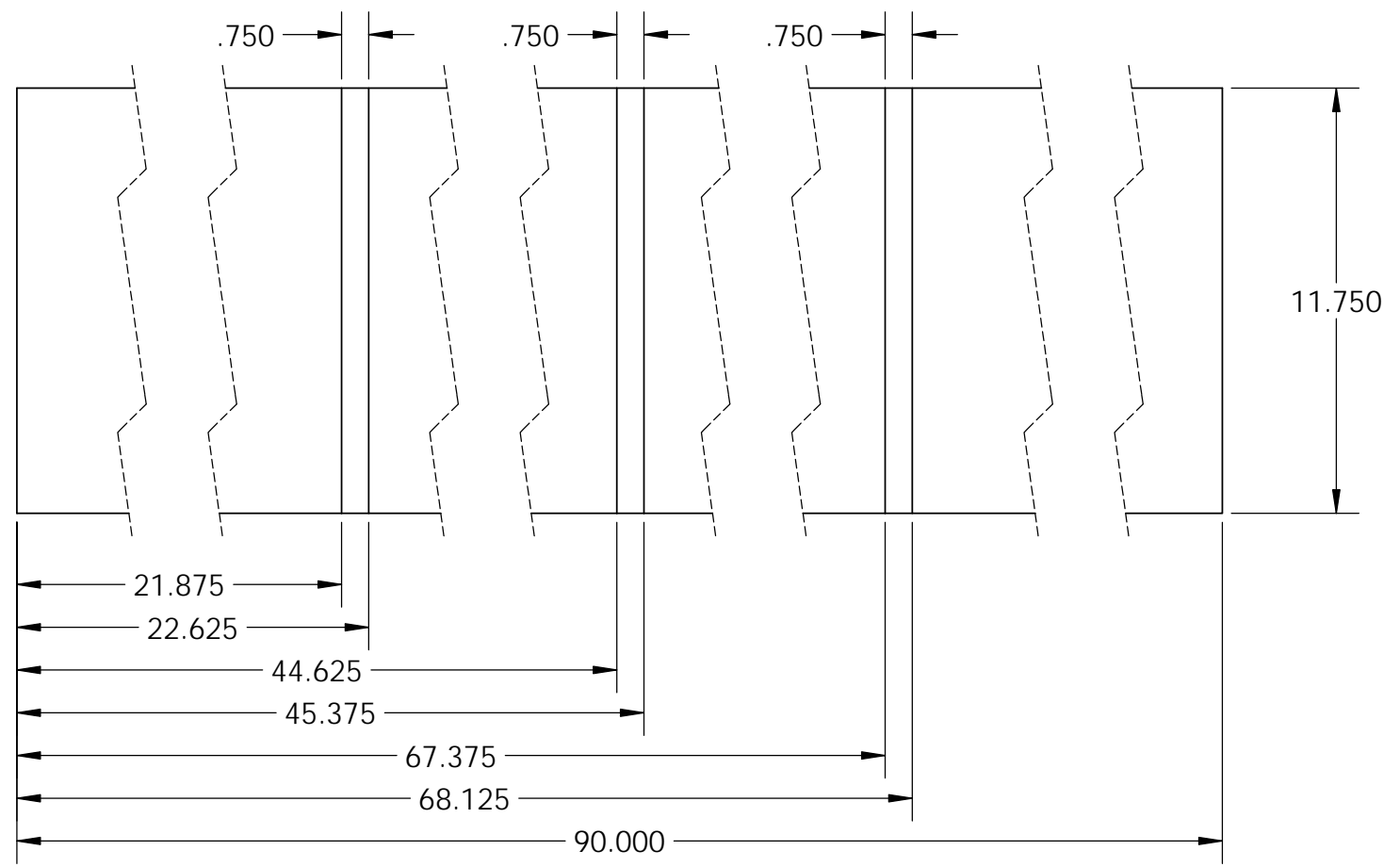
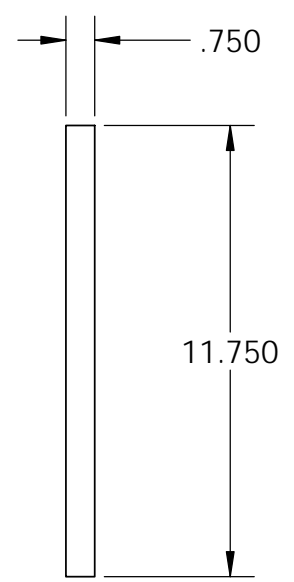

BOTTOM VIEW

UNLESS OTHERWISE SPECIFIED:
DIMENSIONS ARE IN INCHES
AND INCLUDE THICKNESS OF PLATING
TOLERANCES:

BASIC DIMENSIONS	2 PLACE DECIMALS	3 PLACE DECIMALS
UP TO 6	±.02	±.005
6 TO 24	±.03	±.010
ABOVE 24	±.06	±.015

ANGULAR DIMENSIONS ± 0.5°
MATERIAL:
PLYWOOD
FINISH:
STAIN & LACQUER

	NAME	DATE
DESIGN BY		
DRAWN BY	DBC	05/03/14
CHECKED BY		
APPROVED BY		

PROPRIETARY AND CONFIDENTIAL
THE INFORMATION CONTAINED IN THIS DRAWING IS THE PROPERTY OF DONALD B. CHEKE, SOLE PROPRIETOR OF TEXTUAL CREATIONS. COPYRIGHT 2014.
ANY REPRODUCTION IN PART OR AS A WHOLE WITHOUT THE WRITTEN PERMISSION OF TEXTUAL CREATIONS IS PROHIBITED.

TextualCreations
MORE THAN JUST WORDS ON PAPER

TITLE:
**UPPER CABINET
TOP & BOTTOM PANEL**

SIZE	DWG. NO.	REV
B		

SCALE: 1:5 WG: SHEET 25 OF 32

REVISIONS				
REV.	ZONE	DESCRIPTION	DATE	BY

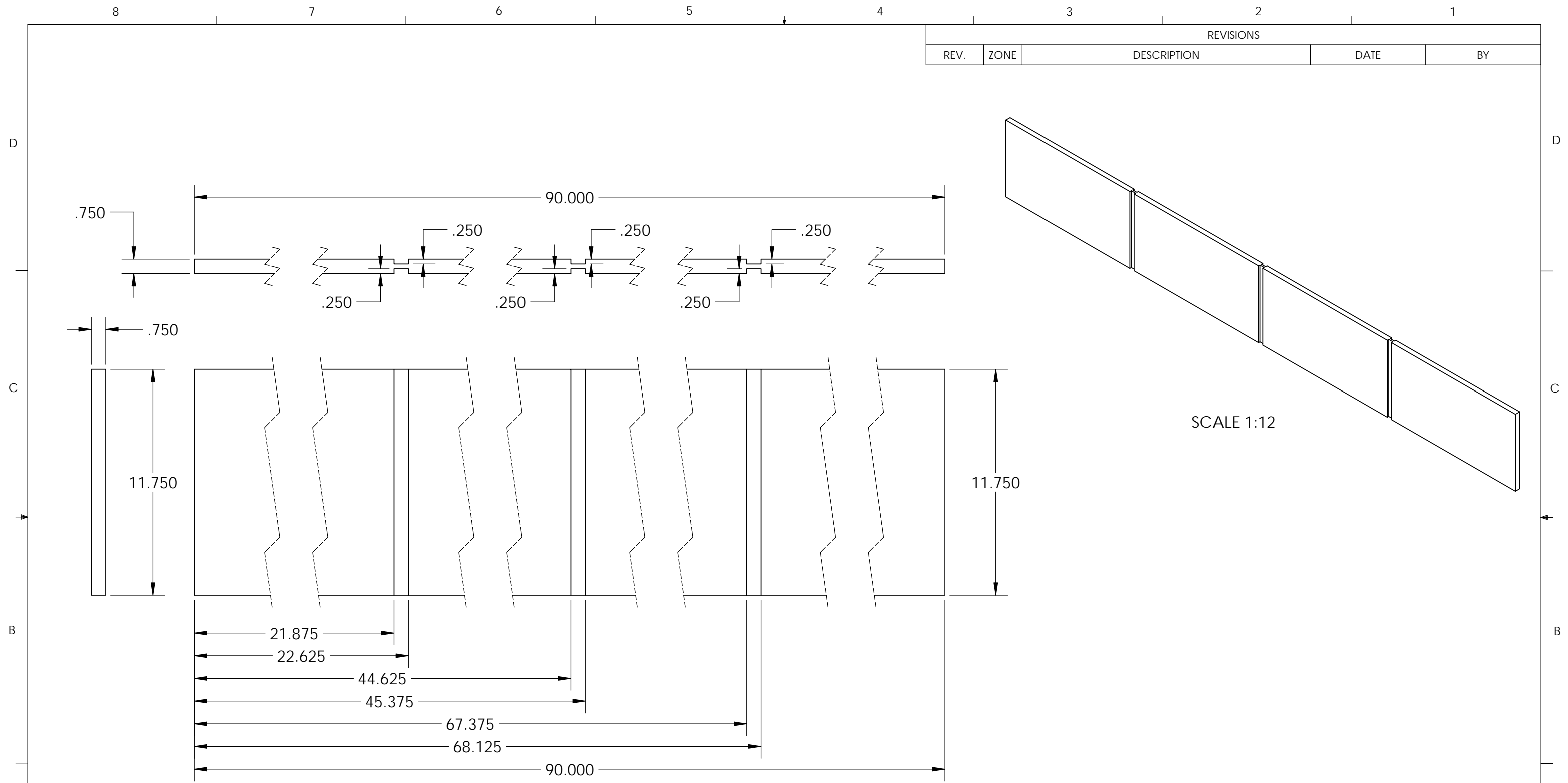

UNLESS OTHERWISE SPECIFIED:
DIMENSIONS ARE IN INCHES
AND INCLUDE THICKNESS OF PLATING
TOLERANCES:

BASIC DIMENSIONS	2 PLACE DECIMALS	3 PLACE DECIMALS
UP TO 6	±.02	±.005
6 TO 24	±.03	±.010
ABOVE 24	±.06	±.015

ANGULAR DIMENSIONS ± 0.5°
MATERIAL:
PLYWOOD
FINISH:
STAIN & LACQUER

	NAME	DATE
DESIGN BY		
DRAWN BY	DBC	05/03/14
CHECKED BY		
APPROVED BY		

PROPRIETARY AND CONFIDENTIAL
THE INFORMATION CONTAINED IN THIS DRAWING IS THE PROPERTY OF DONALD B. CHEKE, SOLE PROPRIETOR OF TEXTUAL CREATIONS. COPYRIGHT 2014.
ANY REPRODUCTION IN PART OR AS A WHOLE WITHOUT THE WRITTEN PERMISSION OF TEXTUAL CREATIONS IS PROHIBITED.

TextualCreations
MORE THAN JUST WORDS ON PAPER

TITLE:
UPPER CABINET MIDDLE SHELF

SIZE B	DWG. NO.	REV
SCALE: 1:5	WG:	SHEET 26 OF 32

8 7 6 5 4 3 2 1

REVISIONS				
REV.	ZONE	DESCRIPTION	DATE	BY

D
C
B
A

D
C
B
A

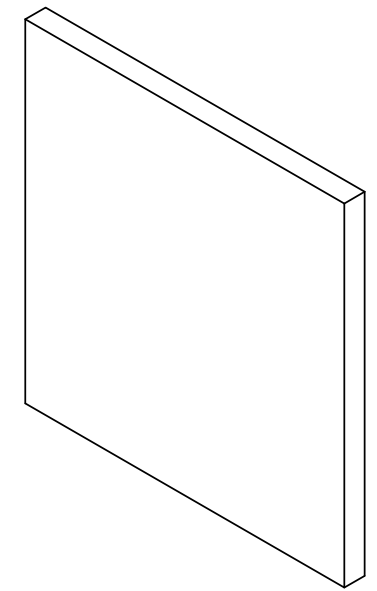
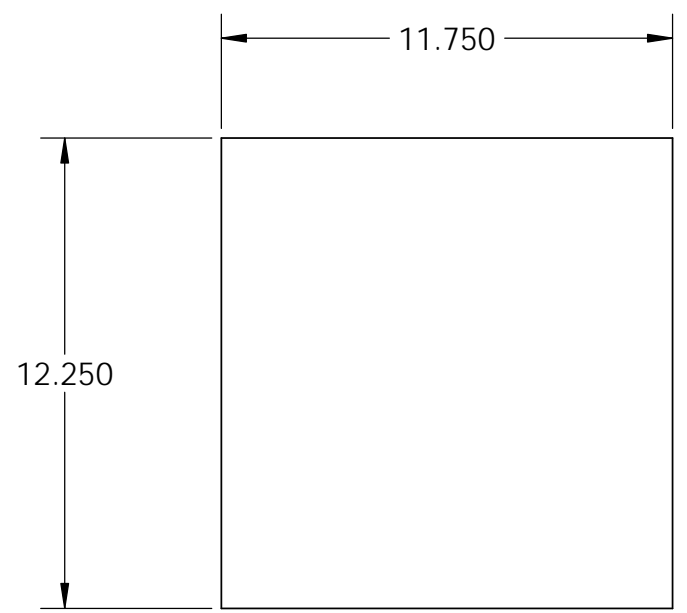
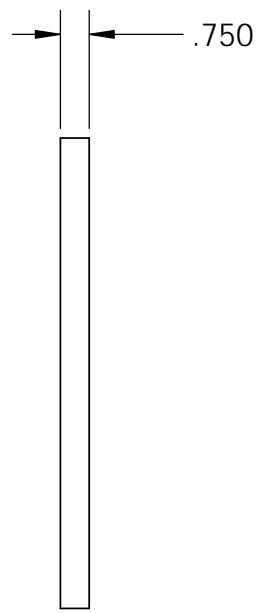

<p>UNLESS OTHERWISE SPECIFIED: DIMENSIONS ARE IN INCHES AND INCLUDE THICKNESS OF PLATING TOLERANCES:</p> <table border="1"> <thead> <tr> <th colspan="3">TOLERANCES ON:</th> </tr> <tr> <th>BASIC DIMENSIONS</th> <th>2 PLACE DECIMALS</th> <th>3 PLACE DECIMALS</th> </tr> </thead> <tbody> <tr> <td>UP TO 6</td> <td>±.02</td> <td>±.005</td> </tr> <tr> <td>6 TO 24</td> <td>±.03</td> <td>±.010</td> </tr> <tr> <td>ABOVE 24</td> <td>±.06</td> <td>±.015</td> </tr> </tbody> </table> <p>ANGULAR DIMENSIONS ± 0.5° MATERIAL: PLYWOOD FINISH: STAIN & LACQUER</p>	TOLERANCES ON:			BASIC DIMENSIONS	2 PLACE DECIMALS	3 PLACE DECIMALS	UP TO 6	±.02	±.005	6 TO 24	±.03	±.010	ABOVE 24	±.06	±.015	<table border="1"> <tr> <td>DESIGN BY</td> <td>NAME</td> <td>DATE</td> </tr> <tr> <td>DRAWN BY</td> <td>DBC</td> <td>05/03/14</td> </tr> <tr> <td>CHECKED BY</td> <td></td> <td></td> </tr> <tr> <td>APPROVED BY</td> <td></td> <td></td> </tr> </table>	DESIGN BY	NAME	DATE	DRAWN BY	DBC	05/03/14	CHECKED BY			APPROVED BY			<p>TextualCreations MORE THAN JUST WORDS ON PAPER</p>	
	TOLERANCES ON:																													
	BASIC DIMENSIONS	2 PLACE DECIMALS	3 PLACE DECIMALS																											
	UP TO 6	±.02	±.005																											
6 TO 24	±.03	±.010																												
ABOVE 24	±.06	±.015																												
DESIGN BY	NAME	DATE																												
DRAWN BY	DBC	05/03/14																												
CHECKED BY																														
APPROVED BY																														
	<p>TITLE: UPPER CABINET SHELF DIVIDER</p>																													
	<p>SIZE B</p>	<p>DWG. NO.</p>	<p>REV</p>																											
	<p>SCALE: 1:5</p>	<p>WG:</p>	<p>SHEET 27 OF 32</p>																											

8 7 6 5 4 3 2 1

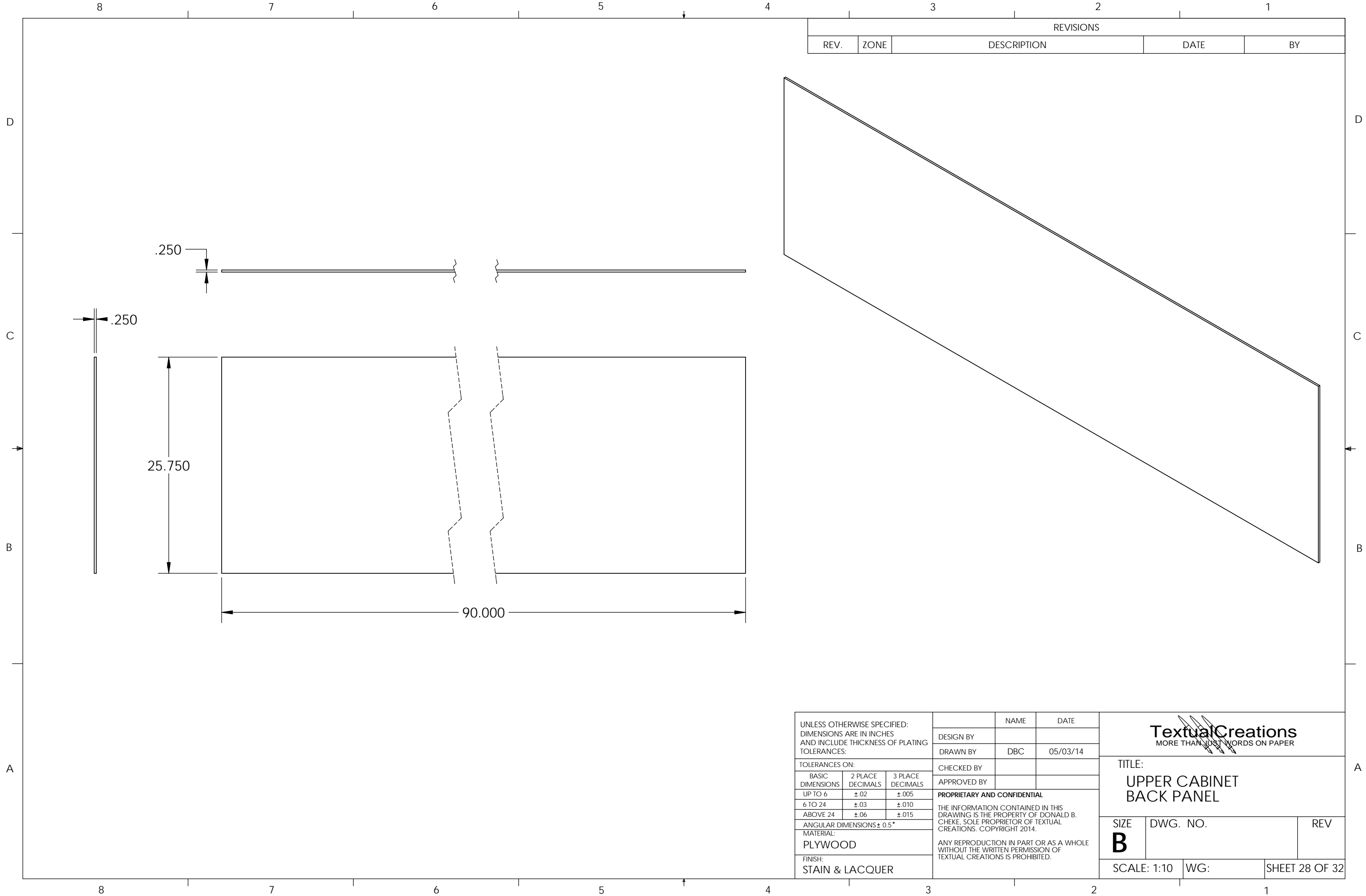

REVISIONS				
REV.	ZONE	DESCRIPTION	DATE	BY

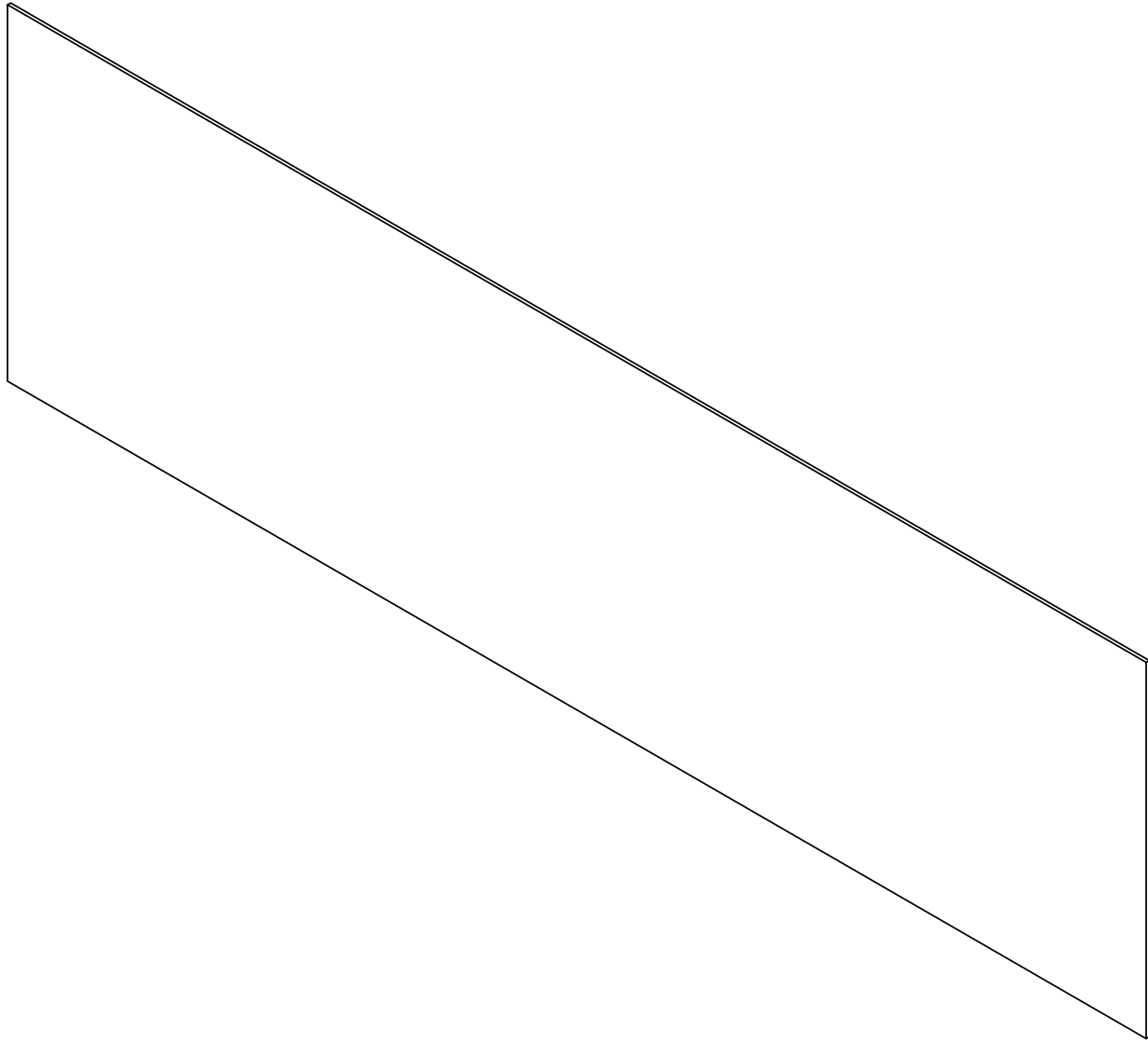
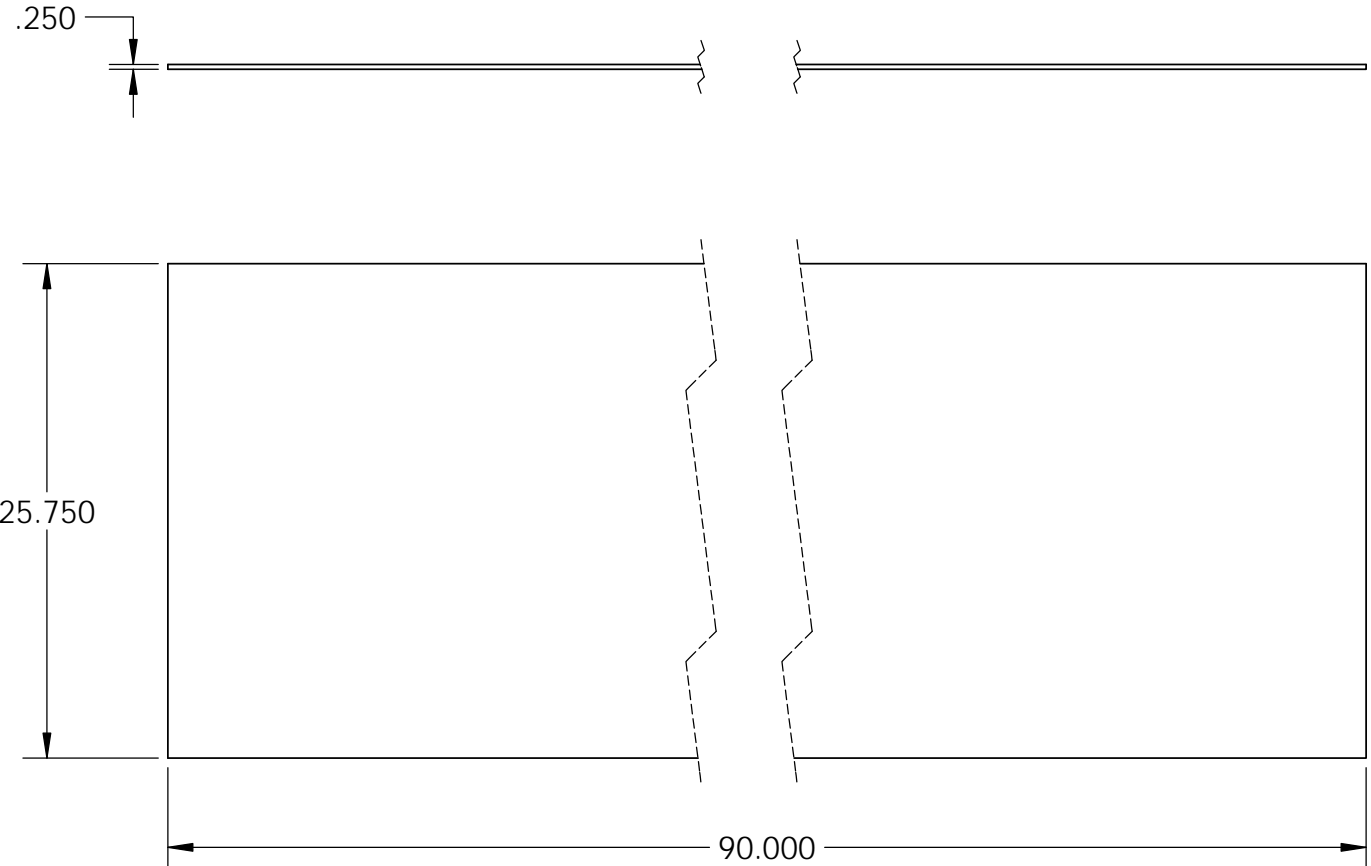

UNLESS OTHERWISE SPECIFIED:
DIMENSIONS ARE IN INCHES
AND INCLUDE THICKNESS OF PLATING
TOLERANCES:

BASIC DIMENSIONS	2 PLACE DECIMALS	3 PLACE DECIMALS
UP TO 6	±.02	±.005
6 TO 24	±.03	±.010
ABOVE 24	±.06	±.015

ANGULAR DIMENSIONS ± 0.5°
MATERIAL:
PLYWOOD
FINISH:
STAIN & LACQUER

	NAME	DATE
DESIGN BY		
DRAWN BY	DBC	05/03/14
CHECKED BY		
APPROVED BY		

PROPRIETARY AND CONFIDENTIAL
THE INFORMATION CONTAINED IN THIS DRAWING IS THE PROPERTY OF DONALD B. CHEKE, SOLE PROPRIETOR OF TEXTUAL CREATIONS. COPYRIGHT 2014.
ANY REPRODUCTION IN PART OR AS A WHOLE WITHOUT THE WRITTEN PERMISSION OF TEXTUAL CREATIONS IS PROHIBITED.

TextualCreations
MORE THAN JUST WORDS ON PAPER

TITLE:
UPPER CABINET BACK PANEL

SIZE	DWG. NO.	REV
B		

SCALE: 1:10 WG: SHEET 28 OF 32

REVISIONS				
REV.	ZONE	DESCRIPTION	DATE	BY

LEFT DOOR ILLUSTRATED, RIGHT DOOR IS MIRROR COPY OF LEFT

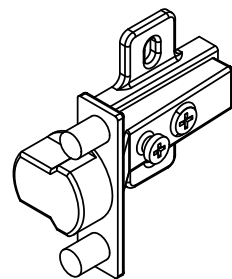
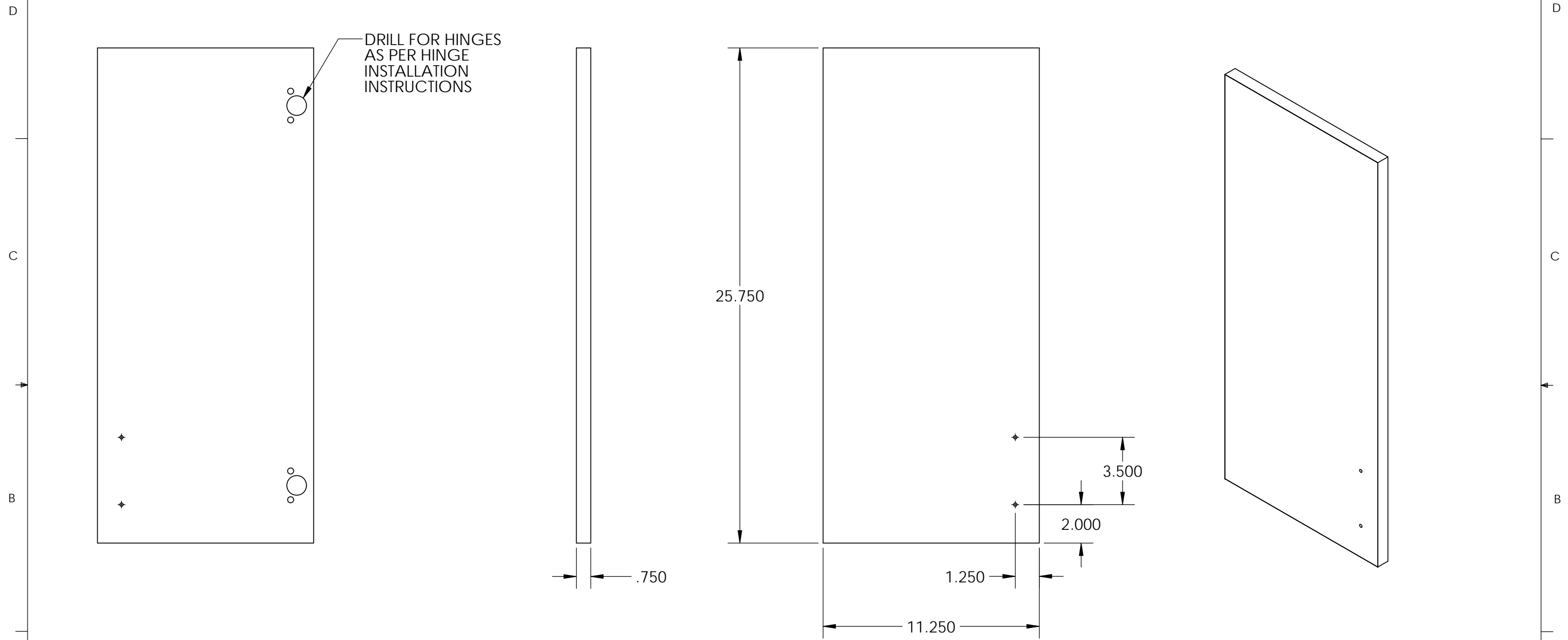

USE EURO HINGES
4 FULL OVERLAY REQUIRED
12 HALF OVERLAY REQUIRED

UNLESS OTHERWISE SPECIFIED:
DIMENSIONS ARE IN INCHES
AND INCLUDE THICKNESS OF PLATING

TOLERANCES ON:

BASIC DIMENSIONS	2 PLACE DECIMALS	3 PLACE DECIMALS
UP TO 6	±.02	±.005
6 TO 24	±.03	±.010
ABOVE 24	±.06	±.015

ANGULAR DIMENSIONS ± 0.5°
MATERIAL:
PLYWOOD
FINISH:
STAIN & LACQUER

NAME	DATE
DESIGN BY	
DRAWN BY	DBC 05/03/14
CHECKED BY	
APPROVED BY	

PROPRIETARY AND CONFIDENTIAL

THE INFORMATION CONTAINED IN THIS DRAWING IS THE PROPERTY OF DONALD B. CHEKE, SOLE PROPRIETOR OF TEXTUAL CREATIONS. COPYRIGHT 2014.

ANY REPRODUCTION IN PART OR AS A WHOLE WITHOUT THE WRITTEN PERMISSION OF TEXTUAL CREATIONS IS PROHIBITED.

TextualCreations
MORE THAN JUST WORDS ON PAPER

TITLE:
UPPER CABINET DOOR PANEL

SIZE B	DWG. NO.	REV
SCALE: 1:5	WG:	SHEET 29 OF 32

REVISIONS				
REV.	ZONE	DESCRIPTION	DATE	BY

2X ϕ .136 ∇ .500
 8-32 UNC - 2B ∇ .500

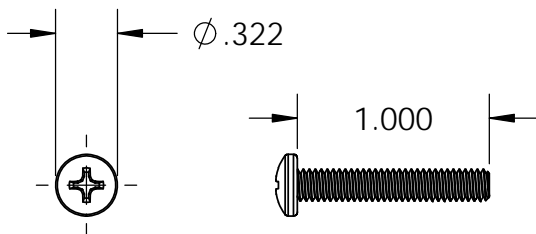
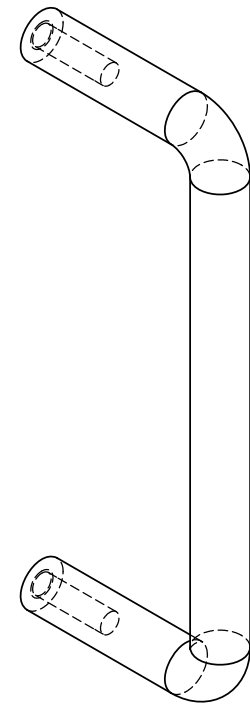
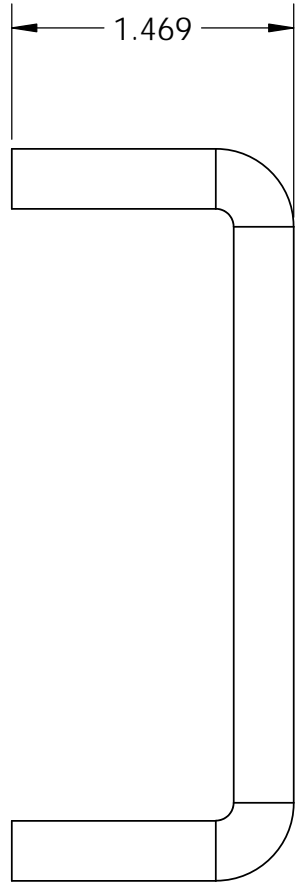
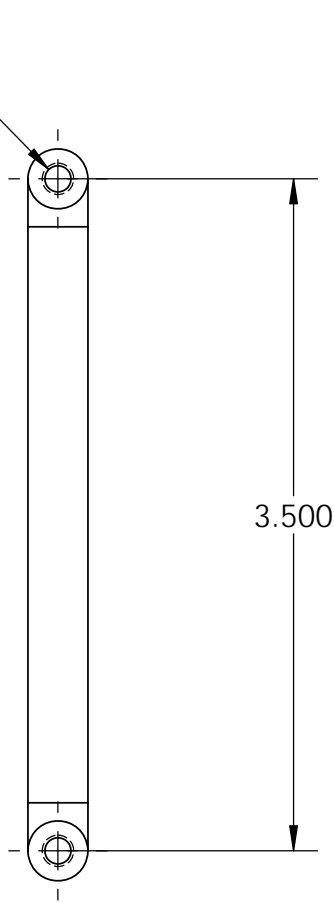

USES 2 SCREWS PER HANDLE
 #8-32 PH PHD ZN MACHINE SCREW (1.000)

UNLESS OTHERWISE SPECIFIED:
 DIMENSIONS ARE IN INCHES
 AND INCLUDE THICKNESS OF PLATING
 TOLERANCES:

BASIC DIMENSIONS	2 PLACE DECIMALS	3 PLACE DECIMALS
UP TO 6	$\pm .02$	$\pm .005$
6 TO 24	$\pm .03$	$\pm .010$
ABOVE 24	$\pm .06$	$\pm .015$

ANGULAR DIMENSIONS $\pm 0.5^\circ$
 MATERIAL:
STEEL OR ALUMINUM
 FINISH:
POLISHED

	NAME	DATE
DESIGN BY		
DRAWN BY	DBC	05/03/14
CHECKED BY		
APPROVED BY		

PROPRIETARY AND CONFIDENTIAL
 THE INFORMATION CONTAINED IN THIS DRAWING IS THE PROPERTY OF DONALD B. CHEKE, SOLE PROPRIETOR OF TEXTUAL CREATIONS. COPYRIGHT 2014.
 ANY REPRODUCTION IN PART OR AS A WHOLE WITHOUT THE WRITTEN PERMISSION OF TEXTUAL CREATIONS IS PROHIBITED.

TextualCreations
 MORE THAN JUST WORDS ON PAPER

TITLE:
CABINET WIRE DOOR PULL

SIZE	DWG. NO.	REV
B		
SCALE: 1:1	WG:	SHEET 30 OF 32

REVISIONS				
REV.	ZONE	DESCRIPTION	DATE	BY

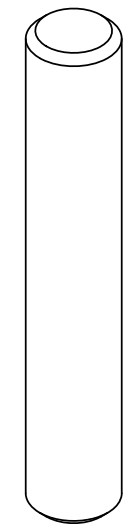
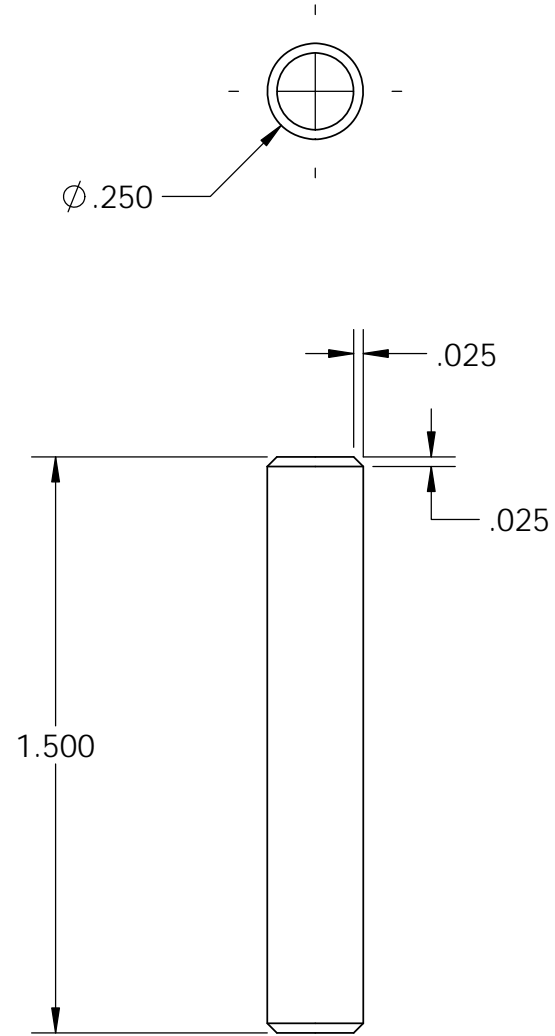

UNLESS OTHERWISE SPECIFIED: DIMENSIONS ARE IN INCHES AND INCLUDE THICKNESS OF PLATING TOLERANCES: TOLERANCES ON: <table border="1"> <thead> <tr> <th>BASIC DIMENSIONS</th> <th>2 PLACE DECIMALS</th> <th>3 PLACE DECIMALS</th> </tr> </thead> <tbody> <tr> <td>UP TO 6</td> <td>±.02</td> <td>±.005</td> </tr> <tr> <td>6 TO 24</td> <td>±.03</td> <td>±.010</td> </tr> <tr> <td>ABOVE 24</td> <td>±.06</td> <td>±.015</td> </tr> </tbody> </table> ANGULAR DIMENSIONS ± 0.5° MATERIAL: HARDWOOD FINISH:	BASIC DIMENSIONS	2 PLACE DECIMALS	3 PLACE DECIMALS	UP TO 6	±.02	±.005	6 TO 24	±.03	±.010	ABOVE 24	±.06	±.015	DESIGN BY	NAME	DATE	 TITLE: DOWEL PIN
	BASIC DIMENSIONS	2 PLACE DECIMALS	3 PLACE DECIMALS													
	UP TO 6	±.02	±.005													
	6 TO 24	±.03	±.010													
ABOVE 24	±.06	±.015														
DRAWN BY	DBC	05/03/14														
CHECKED BY																
APPROVED BY																
PROPRIETARY AND CONFIDENTIAL THE INFORMATION CONTAINED IN THIS DRAWING IS THE PROPERTY OF DONALD B. CHEKE, SOLE PROPRIETOR OF TEXTUAL CREATIONS. COPYRIGHT 2014. ANY REPRODUCTION IN PART OR AS A WHOLE WITHOUT THE WRITTEN PERMISSION OF TEXTUAL CREATIONS IS PROHIBITED.		SIZE	DWG. NO.	REV												
		B														
		SCALE: 2:1	WG:	SHEET 31 OF 32												

8 7 6 5 4 3 2 1

REVISIONS				
REV.	ZONE	DESCRIPTION	DATE	BY

NOTES:

Wood Material

- Birch plywood
- Birch veneer tape on all exposed edges after assembly

Wood Finish

- Stain & Lacquer (2 Coats)

Assembly

- Dowel pins are not to be glued so upper cabinet can be supplied separately

Installation

- Securely fasten upright case to wall through upright case fasten panels. Secure at studs
- Securely fasten upper cabinet to wall through back panel. Secure at studs

Mattress

- Mattress is to be supplied by end user unless otherwise specified
- Platform fits Twin XL Mattress 39" wide x 80" long x 9" thick
- Fastening to platform is to be determined. May be Velcro

D

D

C

C

B

B

A

A

UNLESS OTHERWISE SPECIFIED: DIMENSIONS ARE IN INCHES AND INCLUDE THICKNESS OF PLATING TOLERANCES: TOLERANCES ON: <table border="1"> <thead> <tr> <th>BASIC DIMENSIONS</th> <th>2 PLACE DECIMALS</th> <th>3 PLACE DECIMALS</th> </tr> </thead> <tbody> <tr> <td>UP TO 6</td> <td>±.02</td> <td>±.005</td> </tr> <tr> <td>6 TO 24</td> <td>±.03</td> <td>±.010</td> </tr> <tr> <td>ABOVE 24</td> <td>±.06</td> <td>±.015</td> </tr> </tbody> </table> ANGULAR DIMENSIONS ± 0.5° MATERIAL: HARDWOOD FINISH:	BASIC DIMENSIONS	2 PLACE DECIMALS	3 PLACE DECIMALS	UP TO 6	±.02	±.005	6 TO 24	±.03	±.010	ABOVE 24	±.06	±.015	DESIGN BY	NAME	DATE	
	BASIC DIMENSIONS	2 PLACE DECIMALS	3 PLACE DECIMALS													
	UP TO 6	±.02	±.005													
	6 TO 24	±.03	±.010													
ABOVE 24	±.06	±.015														
DRAWN BY	DBC	05/03/14														
CHECKED BY																
APPROVED BY																
PROPRIETARY AND CONFIDENTIAL THE INFORMATION CONTAINED IN THIS DRAWING IS THE PROPERTY OF DONALD B. CHEKE, SOLE PROPRIETOR OF TEXTUAL CREATIONS. COPYRIGHT 2014. ANY REPRODUCTION IN PART OR AS A WHOLE WITHOUT THE WRITTEN PERMISSION OF TEXTUAL CREATIONS IS PROHIBITED.		TITLE: DOWEL PIN		SIZE B												
		DWG. NO.	REV	SCALE: 2:1 WG: SHEET 32 OF 32												

8 7 6 5 4 3 2 1