

# Applying Appearances to a Part

Autodesk Inventor appearances have been updated and now work slightly different from how they used to. We have two sections, a Material Browser and an Appearance Browser.

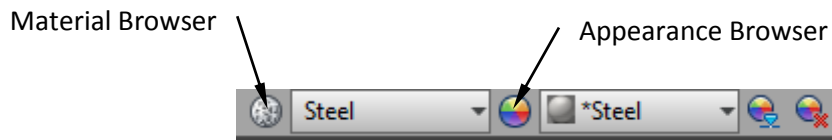

Figure 1 Showing Material and Appearance tool bar Icon

In this example we will change the Appearance colour of a part and add a weld bump map.

Open Welded Body.ipt

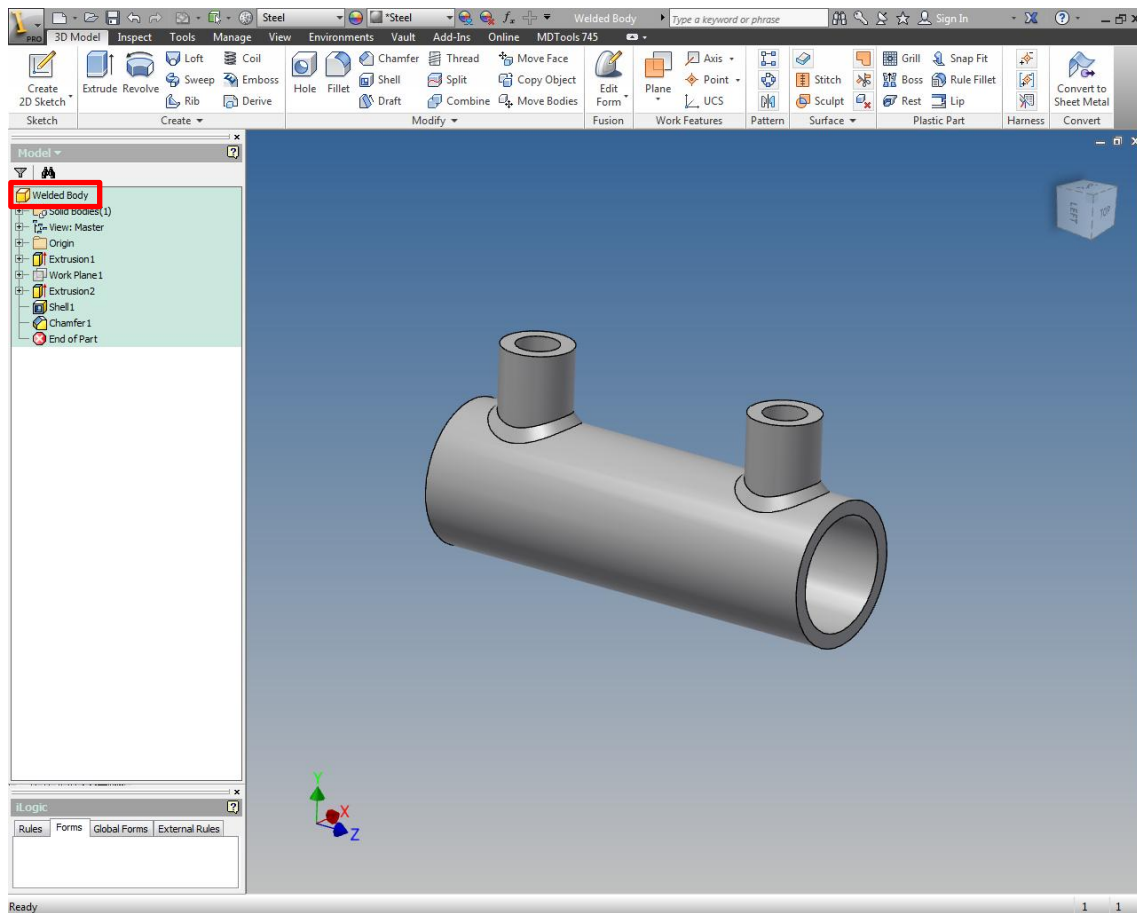

Figure 2 - Showing Welded Body.ipt inventor part

Click "Welded Body" name in the feature tree to select all of the part.

Now click on the Appearance Browser Icon.

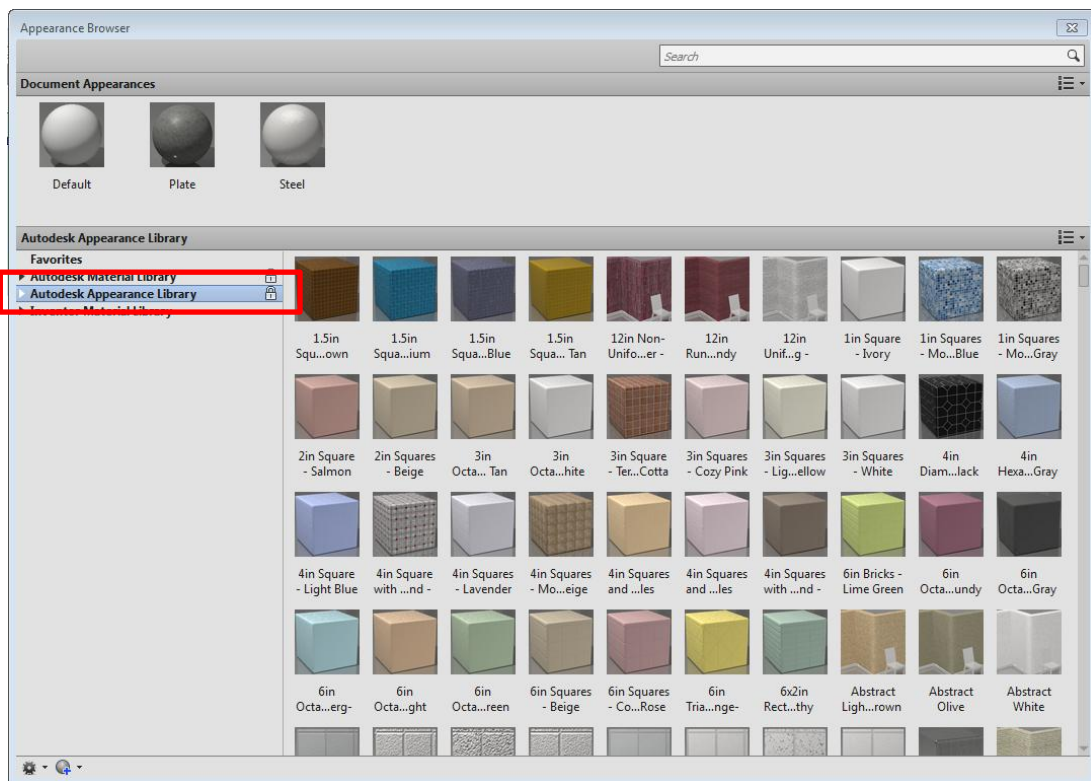

Figure 3 - Showing the Appearance Browser window

Depending on what other Autodesk software you have installed, you may see more or less material and appearances libraries shown in the Autodesk Appearance Library Feature Tree.

Click on “Autodesk Appearance Library”

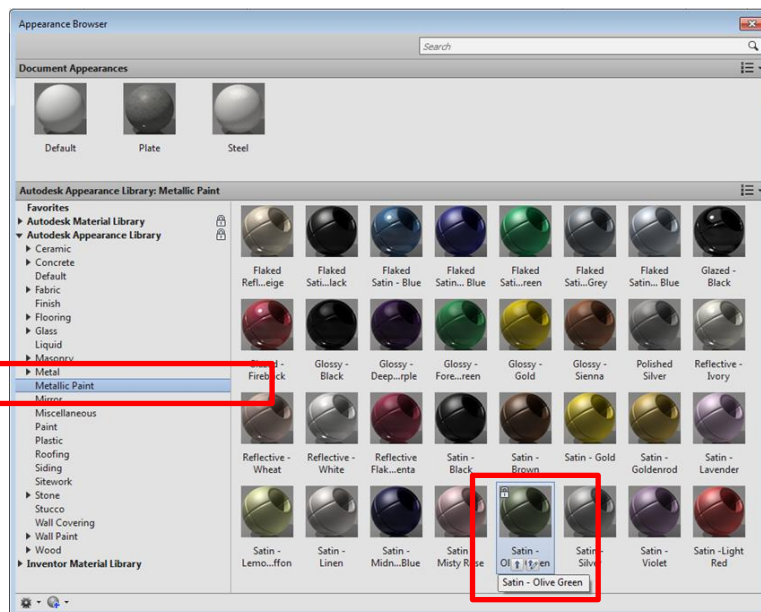

Figure 4 - Showing Appearance Library selection

Now click on Metallic Paint, this will filter the selection to only show what were interested in.

Hover the mouse pointer over “Satin – Olive Green” and add the colour swatch to your colour pallet.

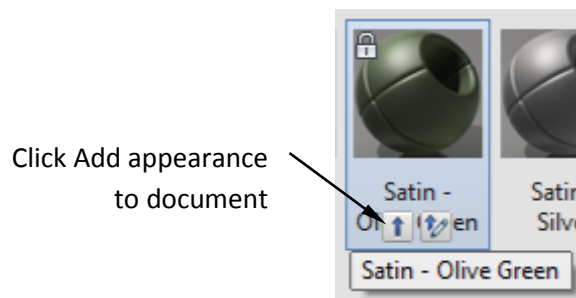

Figure 5 - Showing Material Swatch selection

You should now have this colour swatch added to the Document Appearances. Click it and it should update the colour appearance of the Welded Body.ipt.

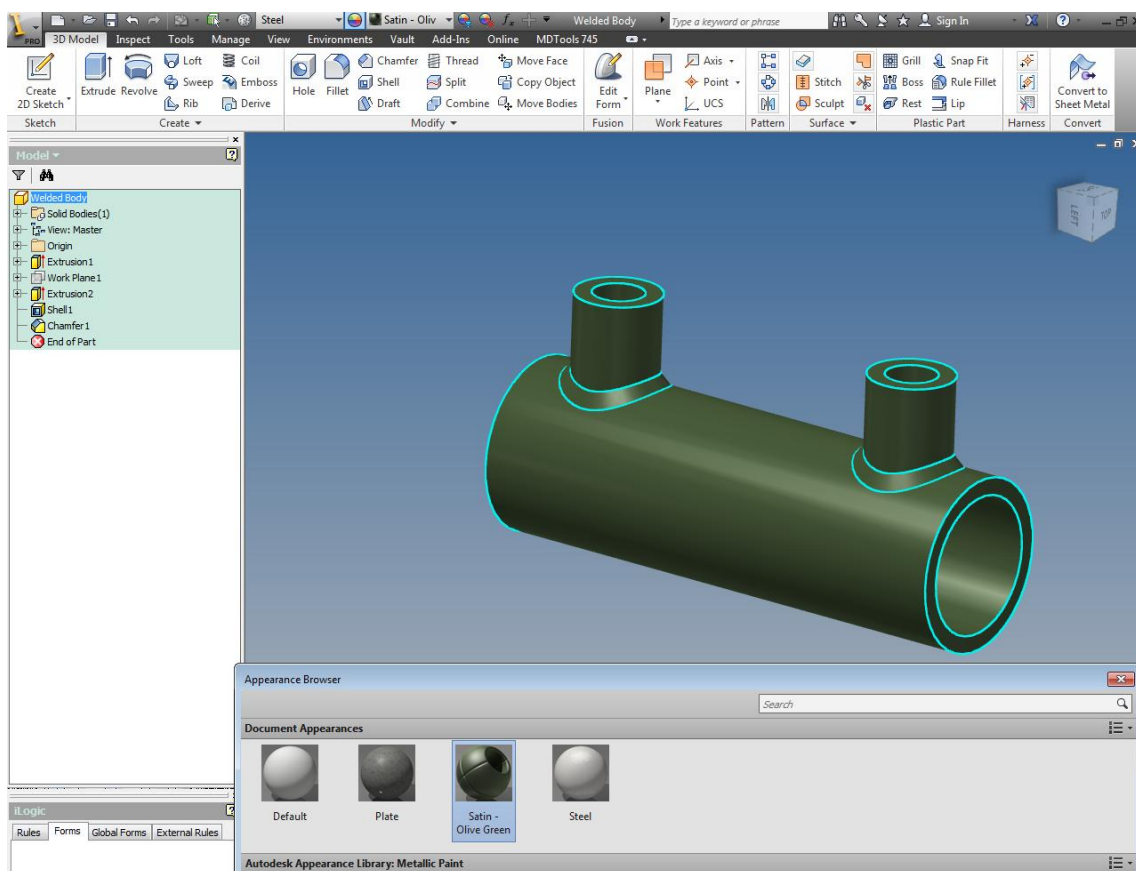

Figure 6 - Showing applied colour on part

Now let's open the Appearance editor for Satin – Olive Green material. Click the Edit Appearance icon found in the Document Appearance (top section) window.

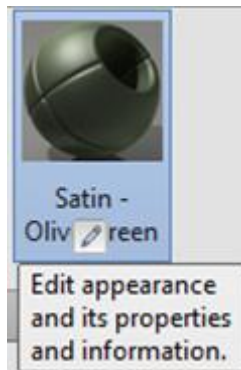

Figure 7 - Showing edit material appearance icon

The appearance Editor window will now show;

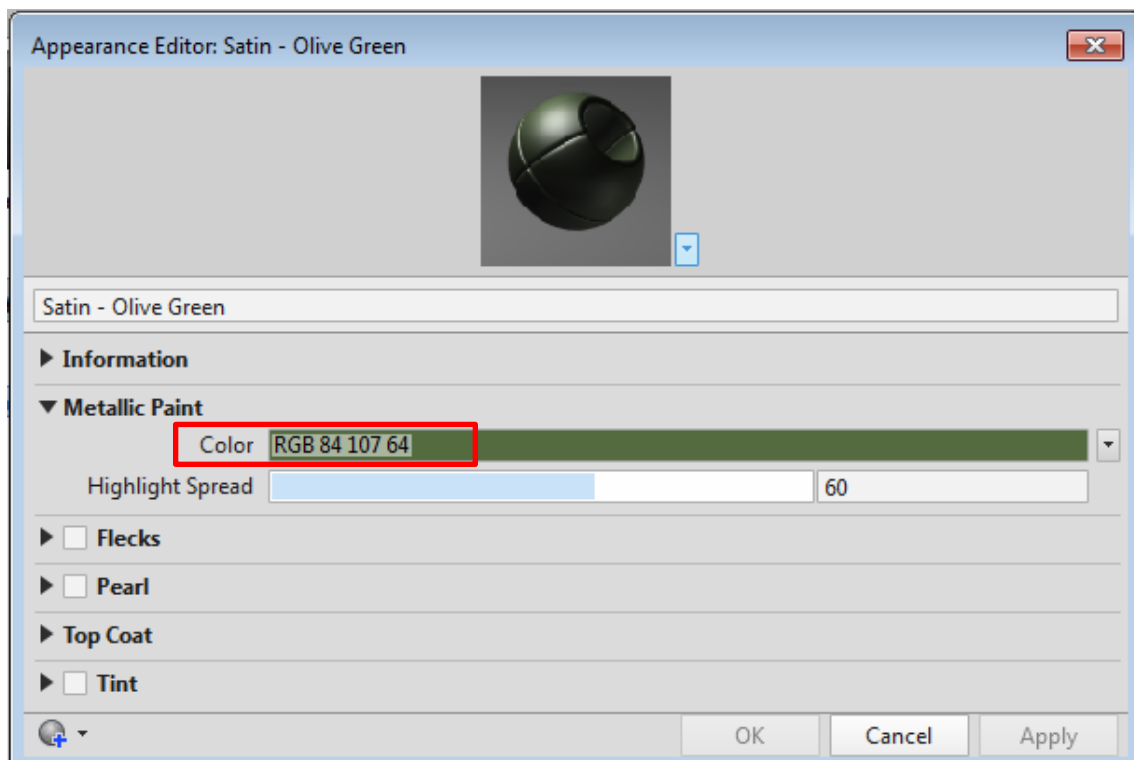

Figure 8 - Showing Appearance editor window

This is where we could change the appearance by adjusting the colour, Flecks, Pearl or tint. All we are interested in now is the Red, Green, Blue (RGB) value. Make a note of RGB 84,107,64. Close this window as it is no longer required.

Let's add a realistic weld appearance to the bosses. In the Appearance Browser Click "Search" tab and type "weld". This will filter through the swatch colours and select all types with "weld" in the name. Click Weld - Steel Mild "Add appearance to document" icon to add the weld swatch to the current document. Now close this window.

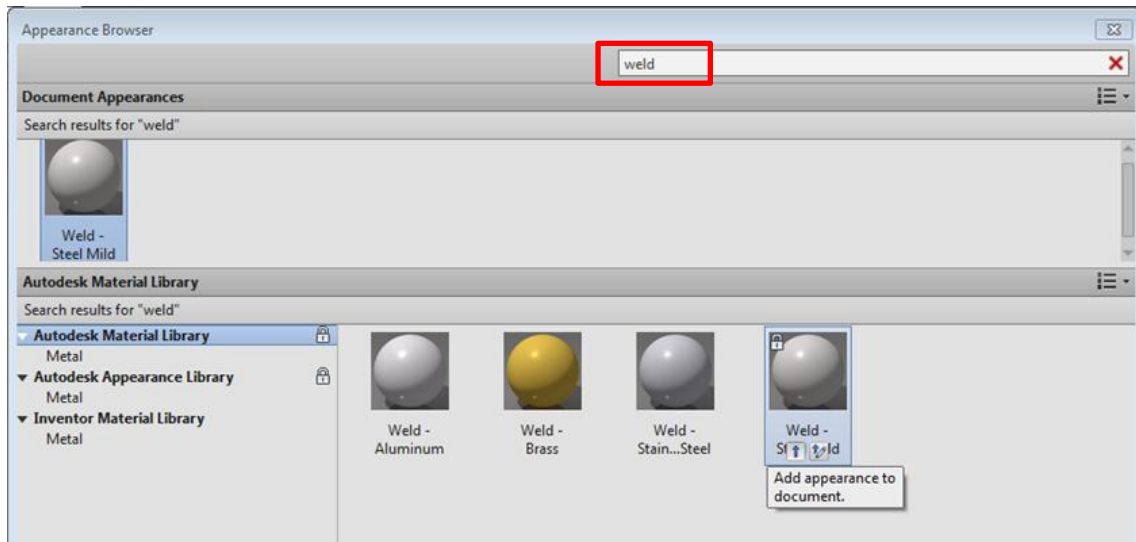

Figure 9 - Showing Search Results

Click Chamfer 1 in the feature manager tree to select the feature we want to change the appearance of. Click the Appearance icon to launch the Appearance Browser Window. Click the "Edit appearance" icon on the Weld – Steel Mild colour swatch.

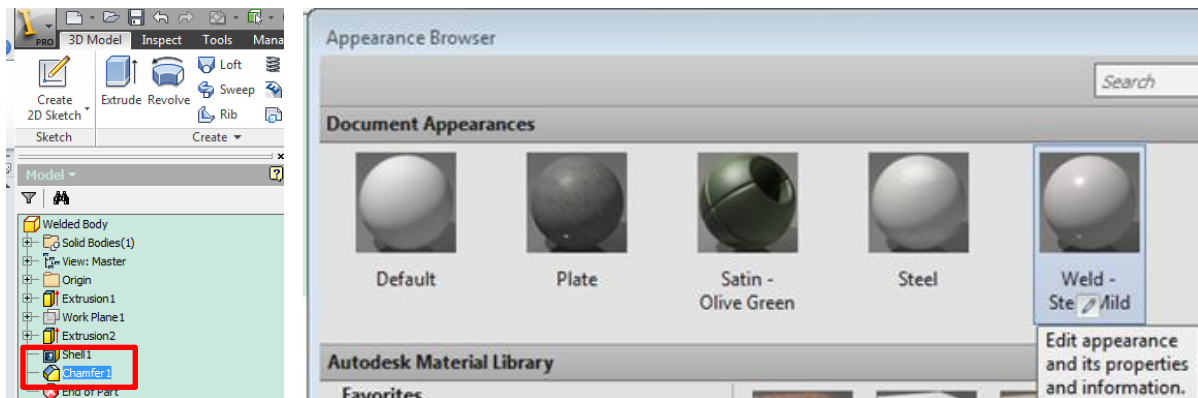

Figure 10 - Showing edit appearance Weld swatch

Click the Weld image (weldcat0.png) found in the Bump section

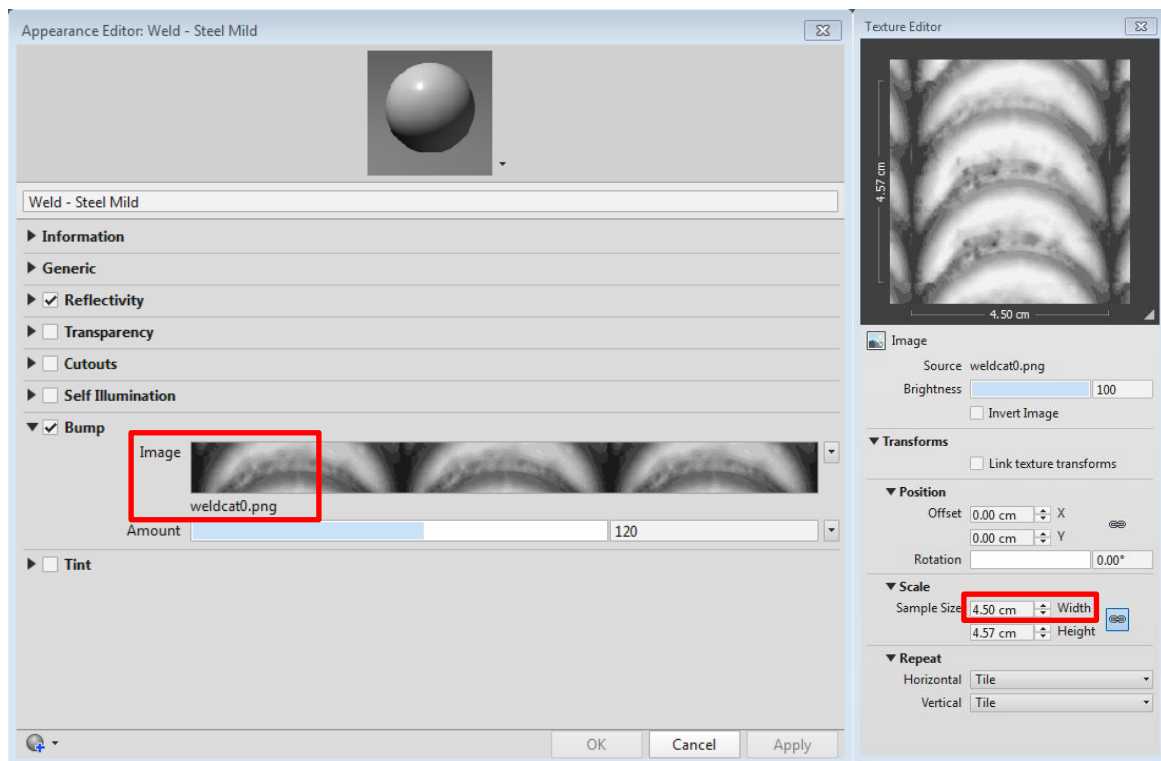

Figure 11 - Showing Weld appearance editor

In the texture edit window notice the width of the bump map is 4.5cm (45mm). This means the weld bump map would look as if it were a 45mm fillet weld. This is a little oversized. We have placed a 3mm chamfer on the boss as a weld, so let's scale down the bump map to say 0.5cm (5mm). Click OK

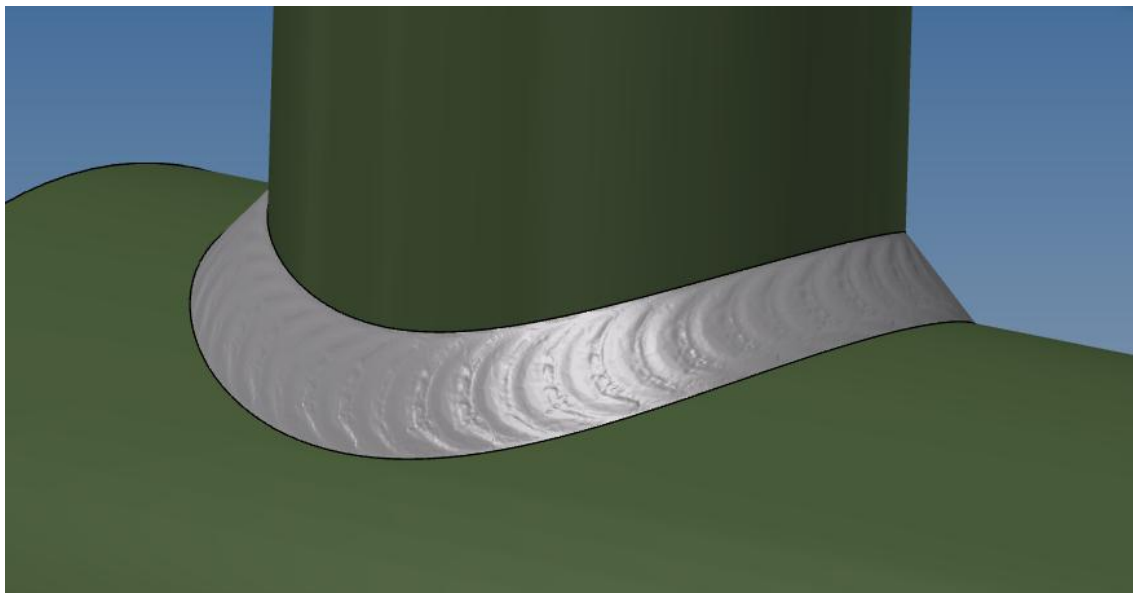

Figure 12 - Showing correctly scales bump map

The weld scale now looks correct. Now we need to adjust how deep the weld ripples are and give it the same colour as the green part (assign the same RGB value).

Click the Appearance icon and then click on the Edit appearance of the Weld – Steel Mild swatch.

Under the Bump section select the “Amount Slider” and push to the right to a value of say 320.

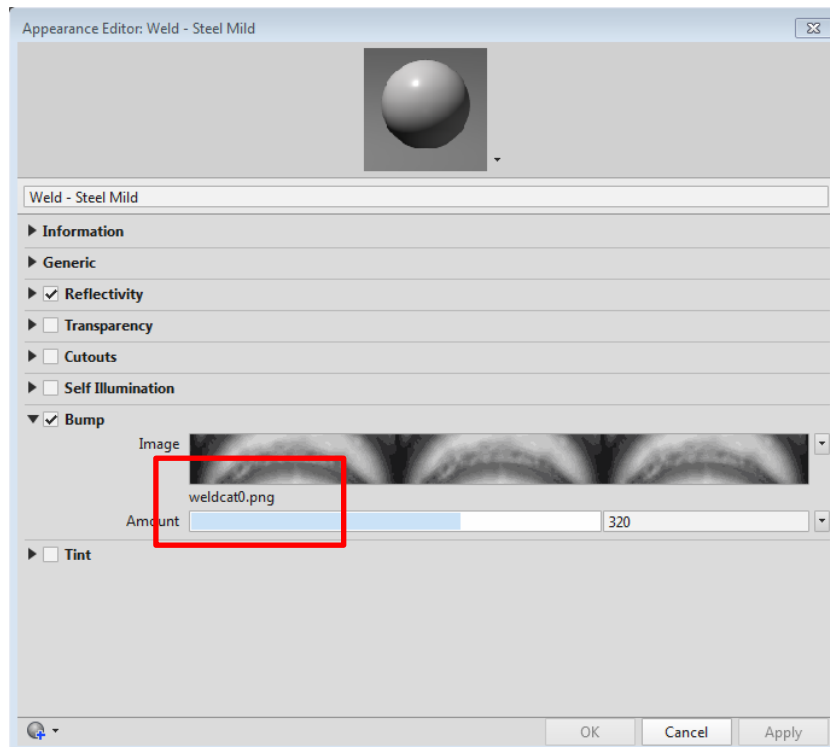

Figure 13 - Showing the Bump amount slider

Now highlight the “Generic” Tab, click Colour, Define Custom Colours and adjust the Red, Green & Blue values to match the Satin Olive Green Values (84,107,64)

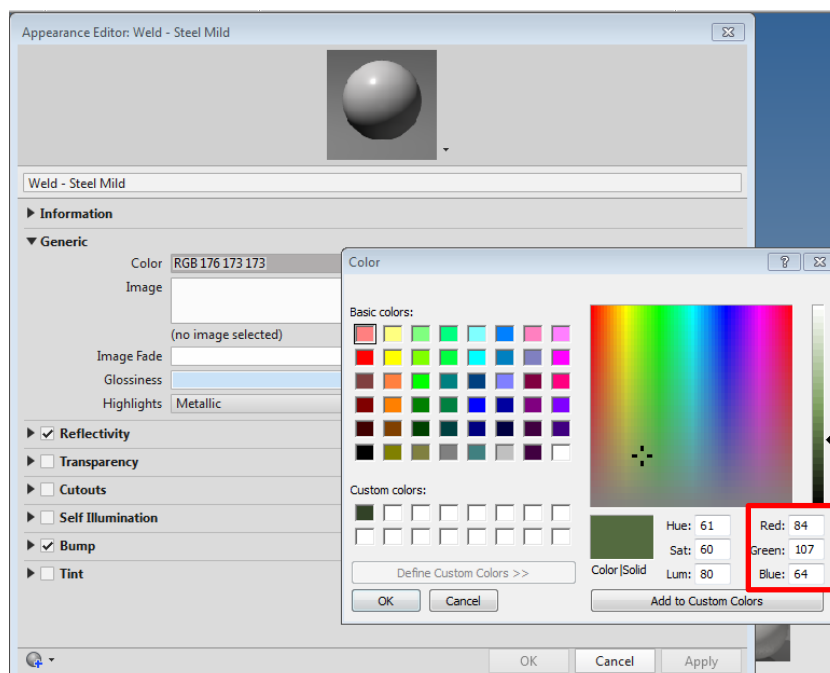

Figure 14 - Showing how to adjust the RGB values

Click OK in the colour window and apply on the Appearance window. Change your view to realistic, go to View> Visual Style> Realistic.

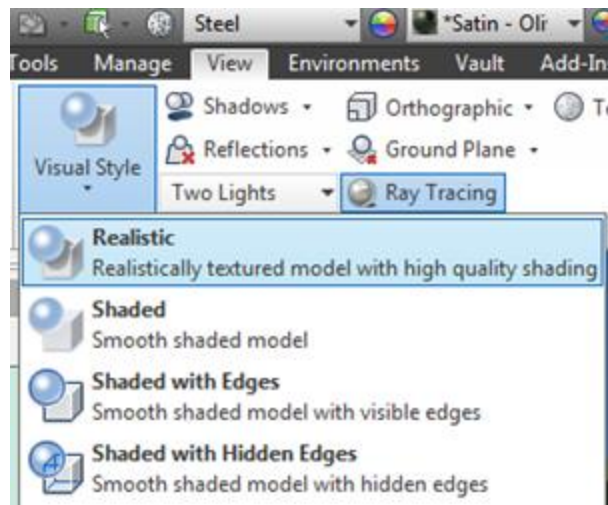
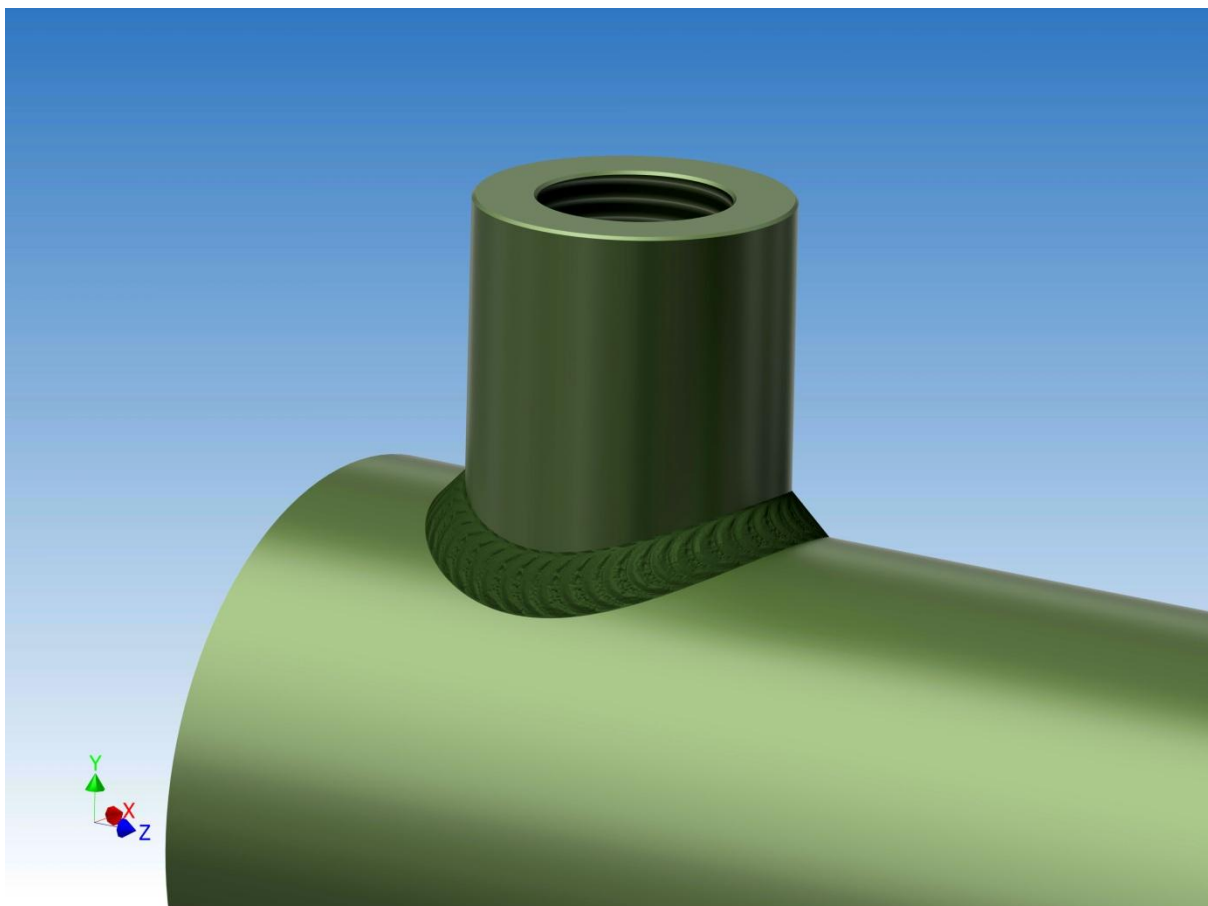

Figure 15 - Showing Final rendered part



The part is now finished.