

K1 Attachments

Renold & ISO 606

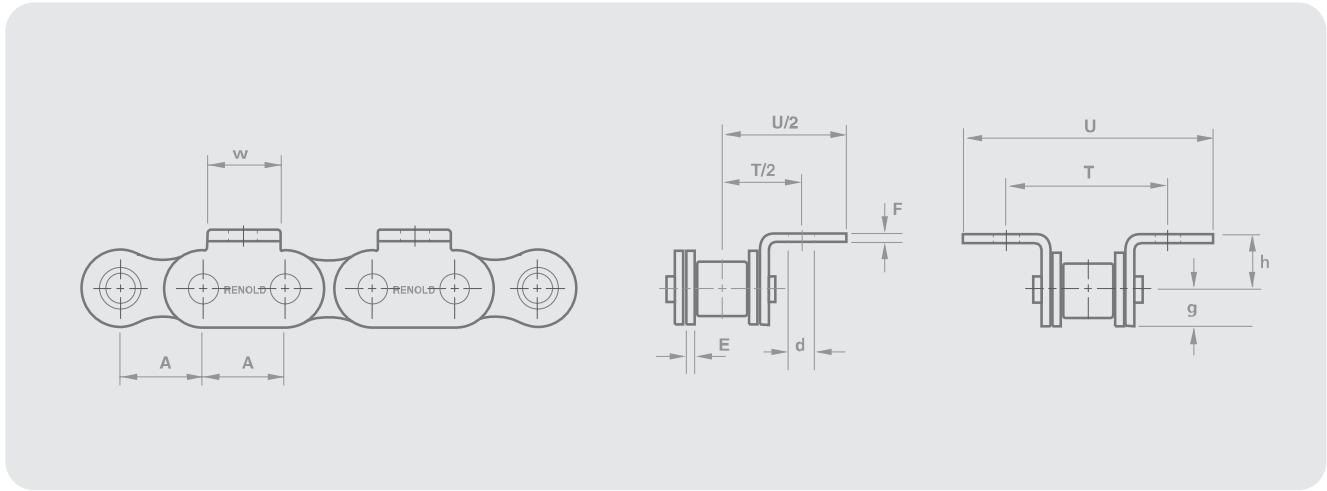

Chain Ref.		Technical Details (mm)									
Renold Chain No.	ISO Ref.	Pitch (inch)	Pitch (mm)								

Renold Standard

		A	A	E	F	w	h	d	g	T	U
08B1	088	0.500	12.700	1.57	1.57	11.56	8.89	4.19	6.80	23.80	37.92
10B1	108	0.625	15.875	1.57	1.57	12.83	10.16	4.98	6.80	31.75	44.45
12B1	128	0.750	19.050	1.83	1.83	16.64	13.49	7.14	8.02	38.10	59.66
16B1	168	1.000	25.400	4.06	3.10	24.32	15.24	6.68	10.27	47.63	74.45
20B1	208	1.250	31.750	4.62	3.61	25.59	19.84	8.08	12.58	63.50	93.62

ISO Standard

		A	A	E	F	w	h	d	g	T	U
1161	04	0.236	6.000	0.57	0.57	5.8	4.5	2.3	2.5	11.2	17.6
05B1	058	0.315	8.000	0.73	0.73	7.8	5.3	2.3	3.4	13.5	21.5
06B1*	068	0.375	9.525	1.25	1.00	8.0	6.7	3.3	4.1	19.6	28.5
08B1	088	0.500	12.700	1.51	1.51	11.0	8.9	4.3	5.9	25.4	41.7
10B1	108	0.625	15.875	1.51	1.51	14.0	10.3	5.3	6.8	31.8	49.0
12B1	128	0.750	19.050	1.76	1.76	18.0	13.5	6.6	8.1	38.1	52.7
16B1	168	1.000	25.400	3.70	3.00	24.0	15.9	6.6	10.5	50.8	85.6
20B1	208	1.250	31.750	4.40	3.50	30.0	19.9	8.4	13.2	63.5	101.0
24B1	248	1.500	38.100	5.40	5.00	36.0	28.0	10.5	16.7	88.0	124.7

*Straight plate

