

Autodesk Inventor®: Best Practices for Working with Large Assemblies (Digital Prototypes)

Dan Miles – INCAT (Tata Technologies)

ML111-1P This session will provide methodologies and best practices for working with large Autodesk Inventor assemblies. With the last few releases of Autodesk Inventor, purpose-built tools have become part of the product for managing and working with large assemblies that consist of thousands of components. With the addition of these new tools, standard processes need to be implemented to ensure that desired productivity levels are achieved. This class will provide detailed information on several methodologies that you can implement, and many tips and tricks for using these tools. If you are a user of Autodesk Inventor or AutoCAD®, this class is for you. You'll leave with information that is sure to increase your productivity when working with large assembly models and drawings.

About the Speaker:

Dan Miles is an INCAT (Tata Technologies) Consulting Director, specializing in helping clients realize superior products. Employed for over nine years at INCAT, a leading global engineering company, Miles consults to hundreds of clients, helping them achieve significant increases in productivity and business growth. He has received two Applications Engineer of the Year awards from Autodesk, instructed hundreds of classes, and is considered an expert on the software. Dan also has experience leveraging global engineering resources to assist with clients business needs.

Email: dan.miles@incat.com

BLOG Site: danmiles.blogs.com

**Autodesk Inventor®:
Best Practices for Working with Large Assemblies (Digital Prototypes)**

Overview

Everyone has a slightly different understanding of a large assembly or digital prototype. Depending on the type of design you do, it could mean different things. Also your environment plays a very important role in this solution. The environment is your computer, software applications, knowledge level, and products you design and work with. In most cases, large assemblies generally consist of either a model with thousands of components or one with very complex components.

Tons of Components

Digital prototype assembly models with many components are the most common large assemblies. There are hundreds and possibly even thousands of different components within the main top-level assembly. While a few thousand component assembly may have been considered a large assembly only a few years ago, today's large assemblies now include over ten thousand components in most cases.

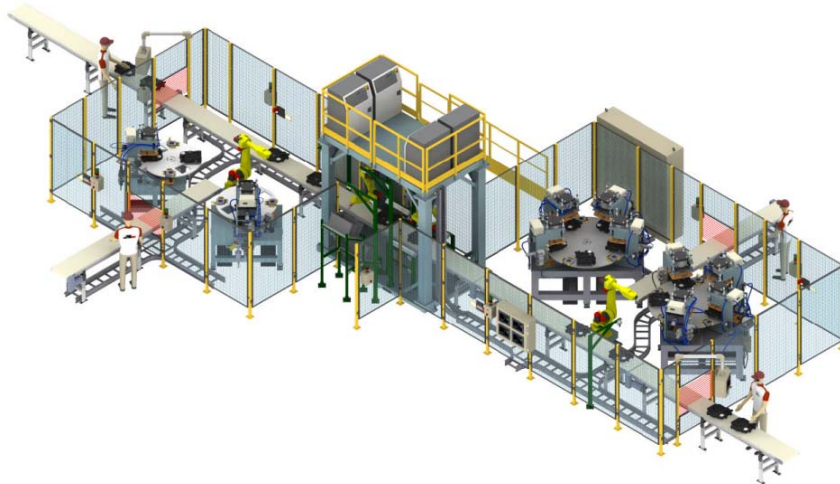

Complex Components

Complex digital prototype assembly models with less than a hundred components can also be considered a large assembly. Often these complex parts have unique geometry like surfaces, lofts, lots of fillets, etc. The parts are generally either a plastic or casted type within Autodesk Inventor or a part translated into Autodesk Inventor from another CAD system. These are considered “heavy” components within an assembly due to their large memory impact.

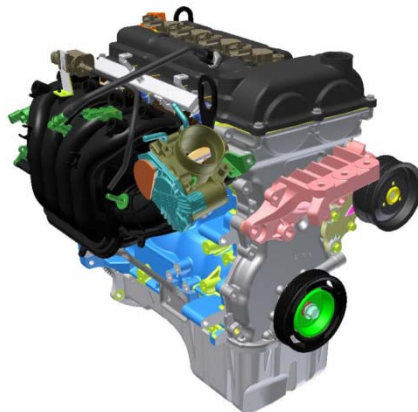

The Foundation

This section outlines some of the most commonly encountered situations where large assemblies and components can slow your performance. These principles are important to understand as it will set the stage for the best practices and solution methods outlined later. Also it will help you understand when it is necessary to apply some of the methodologies. Generally there are three areas that people desire increased performance while working with large assembly models as outlined below.

3D Model Opening

To productively work with a large assembly, one must first open it. This simple step may sound obvious but sometimes models take over an hour to open before you can start working. When launching the program, Inventor reads the assembly structure of the file into memory. If you are using a Data Management solution like Autodesk Vault or Autodesk Productstream, the files are copied to your Data Management workspace local disk area before launching the program. If you are working directly from a network or local drive, the files are already on disk and ready to be opened. Then Autodesk Inventor reads parts of the component files from disk into physical memory. Once everything is loaded into memory, the graphics of the components are displayed on the monitor and Autodesk Inventor is ready to be used.

Listed below are the items that will improve performance when opening large 3D digital prototype assembly models:

- The speed your computer can copy the required files from a Data Management environment to your disk location.
- The speed your computer can read items from disk (hard drive) into physical memory.
- Ensuring that you have enough usable physical memory for the model.
- Reducing the amount of files required to be copied and loaded into memory.
- Reducing the amount of graphics needed to be displayed.
- The speed your computer can display large amounts of graphics.

Slow Performance While Working in 3D

Once the model is open within Autodesk Inventor, now you need to work with it in a productive manner. As you zoom or rotate around the graphics, you are always refreshing and more graphics are loaded resulting in slower performance. Then as you edit existing components or build new components, more information about those parts are loaded into memory that were not loaded during the original open process. Autodesk Inventor uses a segmented database which opens parts of the files as needed. The more you work, the more it loads. Also as you edit and create components Autodesk Inventor is often solving for parameters, assembly constraints, model features, model sketches, etc. Operation lags can be experienced here. If there are lots of components, a simple part edit operation can take a long time as Autodesk Inventor locates and loads the file and solves all of the relationships inherent to that component.

Autodesk Inventor®: Best Practices for Working with Large Assemblies (Digital Prototypes)

Listed below are the items that will improve performance when working with large 3D digital prototype assembly models:

- Faster graphics refresh and display capabilities (display faster or reduce the amount to display).
- Faster memory accessing and solving (read faster or do less).
- Ensure (as you work) the model is still within your computer's physical memory.
- Reduce the amount of items Autodesk Inventor needs to update and solve or simplify the items.
- Reduce the assembly structure size.

Creating Drawing Views and Opening Drawings

There are two main items within the drawing environment that often require better performance for large digital prototypes. These are the initial processing and creation of drawing views or the updating of the views. These two items are due to processing and memory limitations. Simply put, you need to reduce the amount of work the application and computer needs to do must be reduced and only when needed.

Listed below are the items that will assist with improving performance when working with or creating drawings of large digital prototype models:

- Ensuring physical memory capacity is sufficient
- Reducing the amount of complexity of the models within the drawing view.
- Reducing the amount of components within the drawing view.
- Only updating the drawings views as needed.

Computer Hardware Overview

Before embarking upon large assembly design, it is critical to select the right tool for the job. This is also one of the items many users don't take seriously enough. The right computer can save a great deal of time, allowing focus to be maintained on designing and innovation. The increase in time will pay for the hardware within one year if used properly.

64-bit Computing

By now you have heard the word "64-bit" in some context to computers for sure. People have been taking about this new computer architecture for years, which is now mainstream. There are two main advantages to 64-bit computing as outlined below:

- With 64-bit, you gain direct access to more physical memory than 32-bit systems. With 32-bit, you only can access 2 gigabytes (GB) or 3 gigabytes maximum with the memory option in Microsoft Windows. Now with 64-bit computers, you can access far more memory and with some Microsoft operating systems like Window Vista Ultimate you can have up to 128 gigabytes of addressable physical memory. It is very common to have computers with at least 8 GB of memory now as prices have been greatly reduced over the past year.
- Faster processing during true 64-bit applications and processes is now possible. Native 64-bit applications see significant performance improvements particularly for computationally intensive applications. As of today, Autodesk Inventor 2009 is a full native 64-bit application.

One of the keys to working with large digital prototype models is to always work in physical memory. This means never using virtual memory in the form of a paging file on disk. Simply put, loading more data into memory takes more time. One of the slowest parts of a computer is the disk drive. Disk drive technologies have improved but not at the same rate as memory or processor speed. When you run out of physical memory, your computer will start using virtual memory in the form of a page file on your disk drive. Once this happens the performance will dramatically drop to almost an unusable state. Data loaded in physical memory is accessed thousands of times faster than it is on a disk drive to ensure you never run out.

The three items required to take full advantage of 64-bit computers and unleash the benefits noted above are listed below:

- Computer with a 64-bit supported processor. Most purchased workstation computers in the past year have a processor that is 64-bit and all new workstation computers today have 64-bit processors.
- Microsoft operating system that is 64-bit. Some people have a 64-bit processor but not a 64-bit operating system. The following operating systems from Microsoft are supported by Autodesk Inventor:
 - Microsoft Windows XP Professional x64 Edition
 - Microsoft Windows Vista 64-bit

Autodesk Inventor®: Best Practices for Working with Large Assemblies (Digital Prototypes)

- 4 or more gigabytes of physical memory at a minimum will give you the fuel for the 64-bit computer. With the prices of memory today 8 gigabytes or more is recommended when purchasing a new computer. Most computers support up to 4 DIMMS and the 2 GB chips are very affordable now.

Graphics

There are two primary industry standards that CAD applications support and are designed around today. The OpenGL standard is the older most common standard in use while the newer DirectX standard offers some great capabilities and performance. These standards or toolkits are used by companies like Autodesk to develop their graphics engines. Autodesk Inventor 2009 supports both OpenGL and DirectX and is developed to take full advantage of the latest DirectX 10 version while running on Windows Vista. One of the biggest improvements in Windows Vista is not the pretty user interface, but the new version of DirectX that it includes. DirectX 10 offers some major improvements from DirectX 9 and is only available in the Microsoft Windows Vista operating system. Microsoft Windows XP only supports up to DirectX 9. DirectX 10 is the present and future, where OpenGL is the present and the past. Autodesk Inventor 2009 will take advantage of both but utilizes DirectX in Windows Vista. It is believed that Autodesk will continue to leverage the DirectX 10 platform in future releases for even more performance and graphic gains.

Graphic settings can be controlled within Autodesk Inventor 2009 under the “Applications Options” hardware tab. When running Autodesk Inventor on Windows Vista, the Direct3D 10 option should be used. In Windows XP, you can choose between Direct3D and OpenGL. Depending on your graphics card in Windows XP, OpenGL may provide better performance than Direct3D.

Options Available within Windows XP

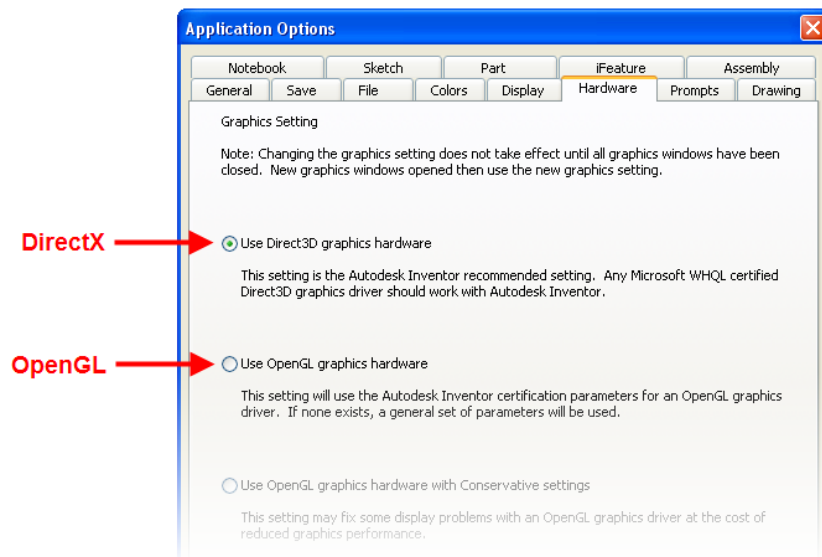

Autodesk Inventor®: Best Practices for Working with Large Assemblies (Digital Prototypes)

Options Available within Windows Vista

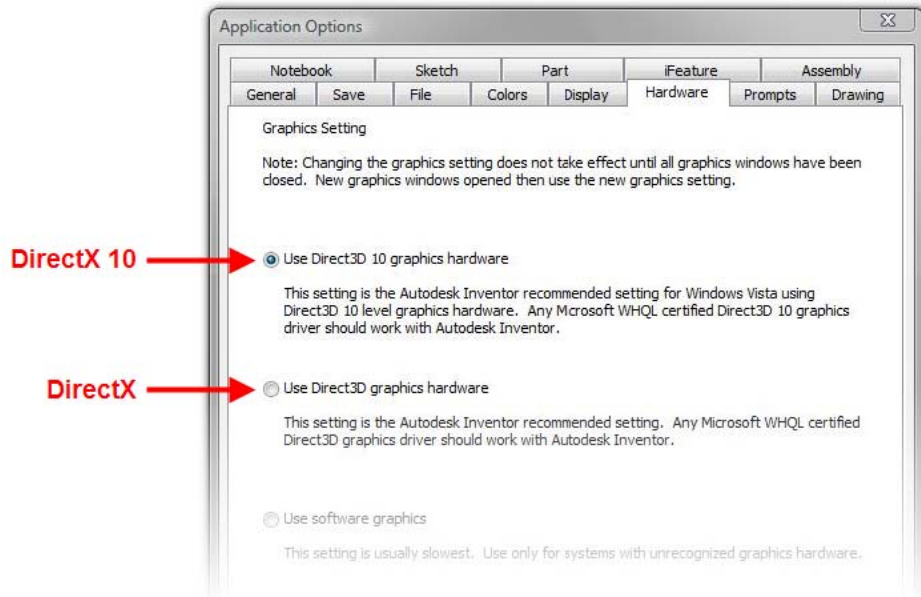

Computer Purchasing Recommendations

Purchasing a new computer is a critical decision faced by many CAD professionals each year. Rapid technological change exacerbates the difficulty of this decision. Additionally, there is always more stuff to buy, so it is important to prioritize the items that will make the biggest impact. Listed below is a prioritized list where I recommend spending money on a workstation computer for Computer Aided Design (CAD).

1. **Physical Memory (RAM)**

Make sure you buy enough capacity for your designs, whether it is 4 GB, 8 GB, or 16 GB, before buying faster memory. If you never plan to buy additional memory for the computer before retiring it or handing it down, fill up the memory bays first, before buying larger DIMMS and leaving bays open to save money. Purchasing four moderately priced 2GB chips in an effective way to achieve 8GB of capacity is highly recommended.

2. **Video Card**

Purchase a middle to upper end of the road 3D CAD graphics card like the nVidia Quadro FX3700 instead of spending more money on the nVidia Quadro FX 4600. Since the technology improves so much each year, use the money savings to buy a new card every year. Computers can be easily kept for two years. Also ensure that you get a video card that is DirectX 10. For best results, stick with the leading manufactures nVidia and ATI. Personally I have never had a problem with nVidia cards. The nVidia Quadro FX series cards are my top pick.

3. **Processor**

All of the processors available now are great. If you have a limited budget, invest in the above items first, and then invest in a better processor. I would recommend that you get some type of a Duo core processor at minimum, and then a Quad core processor, if you have the budget.

4. **Hard Drive**

The hard drive plays a role when opening and saving large files to local disk. Ensure you get at minimum a SATA 3.0Gb/s drive that has a transfer rate of up to 3.0 bits/second. One step up would be a Serial Attached SCSI (SAS) hard drive with a 3.0 bits/second transfer rate. Also if you are not going to store that much data local do not over spend for a larger drive that you will never use.

Note: The computer industry is changing fast so this information may become outdated. As of November 2008 this is current.

Autodesk Inventor Application Options

There are several settings within the Autodesk Inventor 2009 application options dialog that can impact performance and experience while working with large assemblies.

Drawing Tab

Here are a few settings that can help with creating and editing large drawing files.

Display Line Weights

By turning off the “Display Line Weights” option, Autodesk Inventor will not graphically display the view lines with the set line thickness. All of the drawing view lines will be displayed the same, reducing the amount of graphics calculated and displayed. This will help graphic refreshes more than view creation or update time.

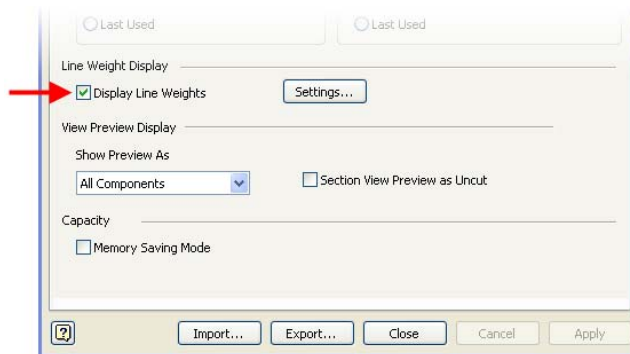

Memory Saving Mode

The “Memory Saving Mode” option under the drawing tab is used to change the way Autodesk Inventor creates and edits drawing views. By default, this option is turned off which ensures that maximum performance is achieved. When the setting is off, Autodesk Inventor does not release memory as it processes each component within the drawing view. When you turn the option on, Autodesk Inventor will load and release component information into memory, allowing you to create views of large models before running out of physical memory. This option will slow down the time required to create and edit views, but will allow you to work on large drawings if needed. Only turn this option on if needed for large or complex assembly drawings.

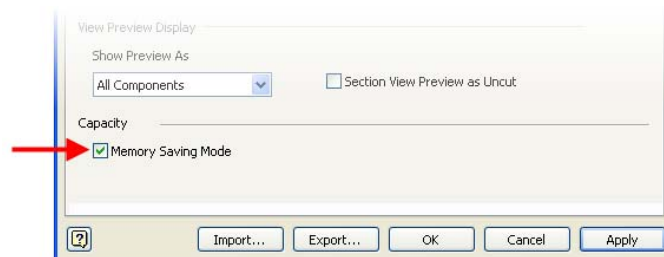

Autodesk Inventor®: Best Practices for Working with Large Assemblies (Digital Prototypes)

View Preview Display – Show Preview As

Changing the “Show Preview As” option to either the “Partial” or “Bounding Box” option will reduce memory consumption and increase the overall time required to create new drawing views. These options change what is displayed on the screen when Autodesk Inventor prompts you to pick a view placement point during view creation. The bounding box option displays the least amount of graphics, providing the best performance, and is the recommended setting.

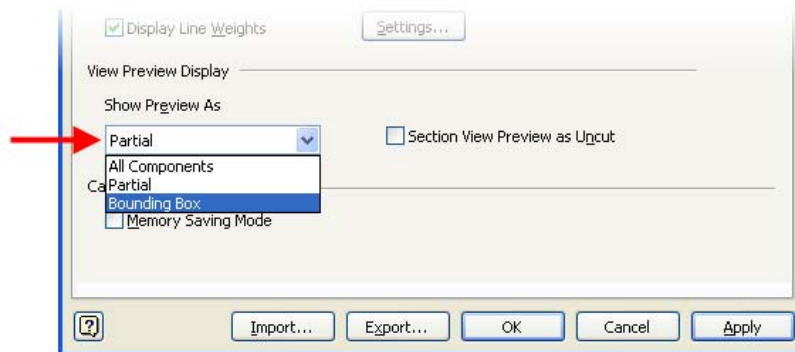

General Tab

Here are a few settings that can help throughout Autodesk Inventor.

Undo File Size

The undo file size controls the size of the temporary file that exists on disk. This feature tracks changes to a model or drawing so that actions can be undone using the undo feature. When working with large files, you need to increase this because each step that is recorded is larger. To do so, enter the size, in megabytes. Use 4 megabyte increments for best results. Using a setting in the range of 768 MB is highly recommended.



Display Tab

A number of settings that can help with graphic displays in the 3D modeling environment are featured below.

Display Quality

The display quality setting sets the resolution for displaying the model. The smoother or more accurate display resolution, the longer it takes to redisplay the model when zooming, rotating, and updating placement or sizes of components. The default setting is “Medium”, however with larger or complex models, the “Rough” setting may be used to reduce graphics impact as needed. It is ok to switch the setting as needed depending on what you are working on. It is not uncommon to change this setting a few times daily.



Enabled Edge Display

By turning off the option to display component edges within a shaded view mode, the required graphics for displaying a model may be reduced. I personally like this viewing type most of the time, except when working with complex parts. This is another setting that may be changed at any time during the day.

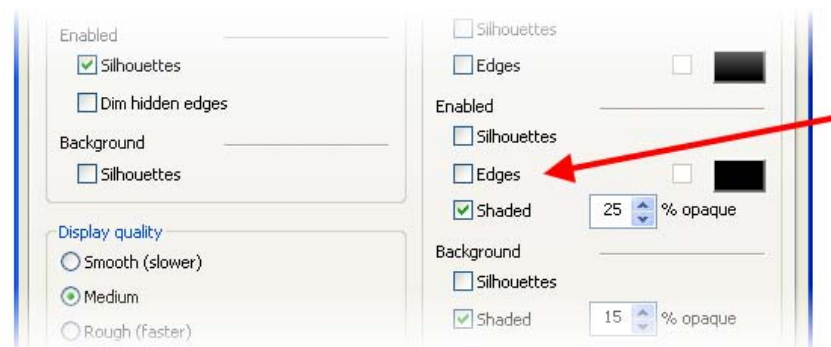

Autodesk Inventor®: Best Practices for Working with Large Assemblies (Digital Prototypes)

View Transition Time and Minimum Frame Rate

The view transition setting value controls the time Autodesk Inventor will take to smoothly transition between views when using some viewing tools. I personally like the view to transition a little quicker than the default setting, so I use a value of 0.5 seconds. The minimum frame rate setting controls how slowly you are willing to update the display during interactive viewing operations. Autodesk Inventor tries to maintain the set frame rate, which means it may need to discard parts of the view at times. Once you are into position, all parts are restored to the view. For example, if you set it to “1”, Autodesk Inventor will try to draw the view at a rate of one frame per second. This is not a common setting to modify but can help in certain cases. The video card is usually the controlling factor here more than anything.

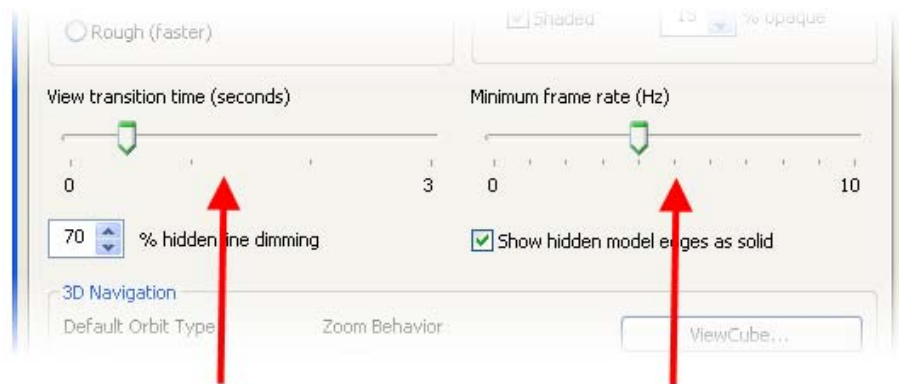

Telemetry / Gauges

Autodesk Inventor provides a telemetry / gauge in the lower right corner of the application called the capacity meter to assist with large assembly management. There are three key items that are monitored and displayed.

Occurrences and Documents

The “Total Occurrences in Active Document” display informs users how many components are in the active document. The “Open Documents in Session” displays how many unique components or documents are open within the Autodesk Inventor session. Except for complex components, generally the lower the numbers, the smaller or less complex the model is.

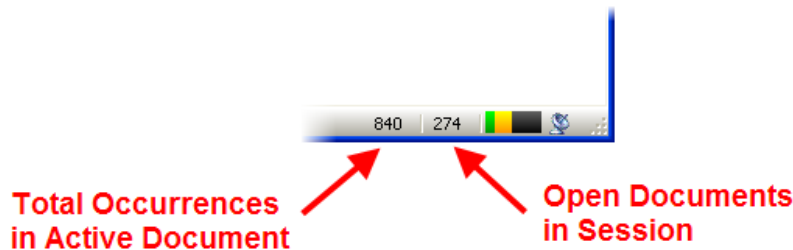

Memory Usage

Autodesk Inventor 2009 now has two different ways to display the memory capacity meter. This can be changed by going to the **Tool/Customize** menu then selecting the option on the **Toolbar tab** in the lower right. Listed below are the two different options available:

Inventor Only (Default Option for 32-bit Computers)

This option only displays the memory for Autodesk Inventor. This is the older option and warns you when you are running out of memory by changing colors from green to yellow and then red when you are out of memory.

Physical Memory (Default Option for 64-bit Computers)

This new option in 2009 works better with computers with additional memory and provides more detailed information. The memory being used by Autodesk Inventor may be identified with this option.

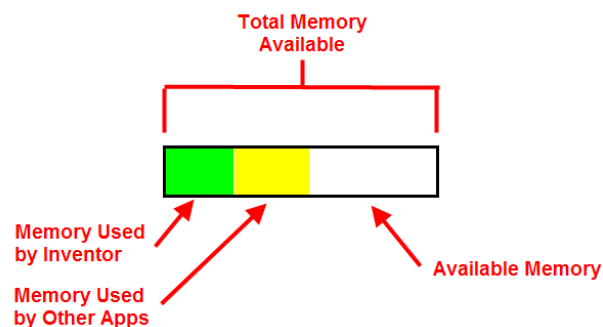

Level of Detail Standard Implementation Methodology

The main purpose of this section is to provide a standardized methodology that can be used to implement the Level of Detail (LOD) functionality from Autodesk Inventor within your company. The use of LOD's must be standardized to allow everyone in your work group or company to use the functionality in the same way, reducing the amount of setup time needed. This will also ensure that you don't have to invest a lot of time to setup a LOD every time you need one, reducing the benefits they offer. This methodology is the most important and is the backbone to working with large digital prototype models.

Autodesk added a new option for the "Level of Detail" (LOD) functionality in release 2009 to enable substituting an assembly file with a part file. This new feature is one of the biggest advancements in release 2009 and can greatly increase the size of assemblies you can work with. The Level of Detail functionality is not often implemented successfully within companies in a productive manner. The LOD functionality allows you to setup various component loading conditions and substitutions within each assembly file. They function similar to a View Representations, but allow you to tell Inventor which components are loaded within the assembly, helping reducing the memory for the assembly. This functionality is the single essential item for working with large digital prototype assembly models.

Autodesk Inventor provides four (4) default "Level of Detail" (LOD) configurations that allow the suppression of standard categories of assembly components. LOD configurations can be created in each assembly in as great a number as is needed to suit your own needs.

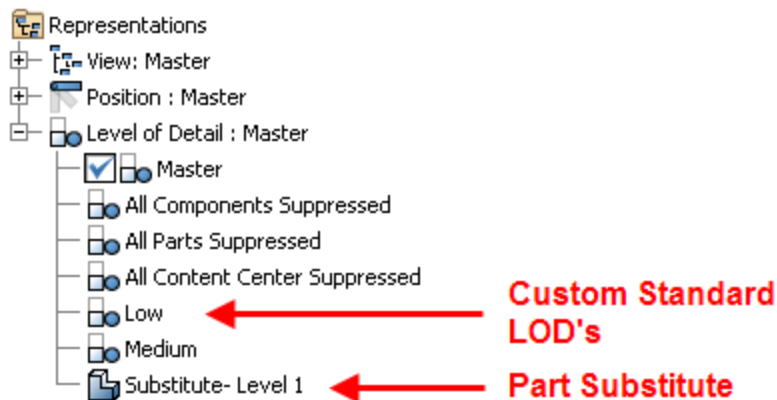

The following method outlines a recommendation for implementing a standardized approach to using LOD functionality within your company or designs. This will ensure that the benefits of using LOD's can be realized when working on huge digital prototype assembly models. This method requires two or three additional custom LOD configurations to be created per each assembly file you wish to control. I recommend getting into the habit of just creating these for almost every assembly so they are there for future use when needed by all users. Listed below are the custom LOD configurations needed and the default master LOD:

Note: You can name the LOD's whatever you like, however using some type of consistent standard convention by all users is highly recommended.

Autodesk Inventor®:

Best Practices for Working with Large Assemblies (Digital Prototypes)

- **“Master” Level of Detail**

The “Master” LOD is a default configuration created by Inventor that enables all components within the assembly to be loaded with no part substitutes. This ensures the most complete model is loaded, but also consumes the most memory. In this LOD the model should be saved in its final state once the design is complete and ready to be released.

- **“Medium” Level of Detail**

The “Medium” LOD is a custom configuration created by the user and contains less components and detail than the overall “Master” LOD. The goal with this custom LOD is to suppress all of the components not required for daily work like fasteners, internal components, and components not in the general work area. This would include the basic items to drop off memory and files.

- **“Low” Level of Detail**

The “Low” LOD is a custom configuration created by the user for each assembly, and contains the least amount of components and detail possible. The purpose of this LOD is to provide the most basic components and detail, which contains fewer components than the “Medium” LOD. This LOD will offer better performance and will require more time to create in some cases.

- **“Substitute – Level 1” Level of Detail**

With the 2009 release of Autodesk Inventor you can now setup a part (IPT File) substitute for an assembly as a LOD. This is the best way to reduce the footprint of the file saving memory. This would be the lowest amount of detail in most cases for the best performance. Also you may setup as many of these different substitutes LOD's as needed. There are several easy ways to create this substitute part that will be covered later in this document like the derived component or shrinkwrap tools.

Level of Detail (LOD) Creation Process

The general process for creating a custom LOD is to right click on the Level of Detail category within the Autodesk Inventor browser and select “New Level of Detail” or “New Substitute”. Once the new LOD is created it may be renamed as desired or to “Medium” or “Low” for example.

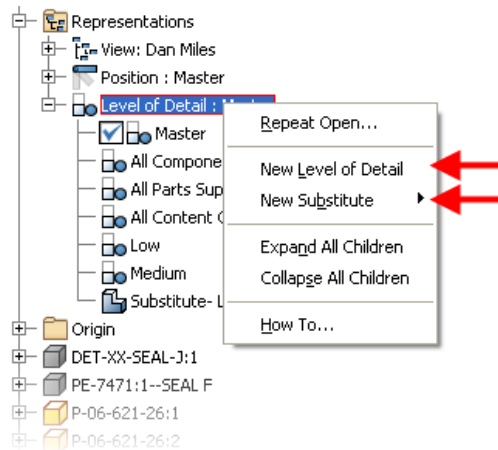

Next when creating a new standard Level of Detail you can right click on a component or components and select “Suppress” for the menu to unload or suppress them. The current active LOD configuration is storing or saving these settings automatically as you change component suppression status. Once you have finished suppressing components, you can change the active LOD back to the “Master” configuration.



When creating a new substitute LOD you can select from either the “Derive Assembly” or “Select Part File” option. The Derive Assembly will take the active assembly file and create a derived part file version and the “Select Part File” will let you pick any IPT part file you like to substitute the assembly with.

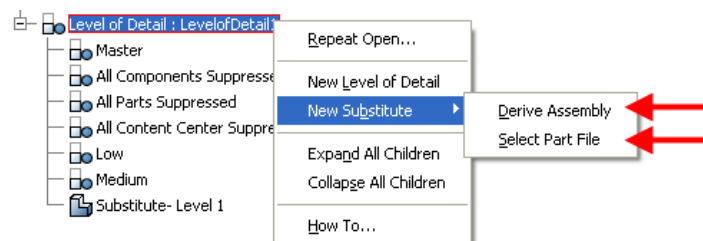

“Master” Level of Detail

The “Master” LOD is the default Autodesk Inventor LOD that always contains all components. By including all components, it is the most memory intensive Level of Detail available.

The image below illustrates an example of a “Master” LOD.

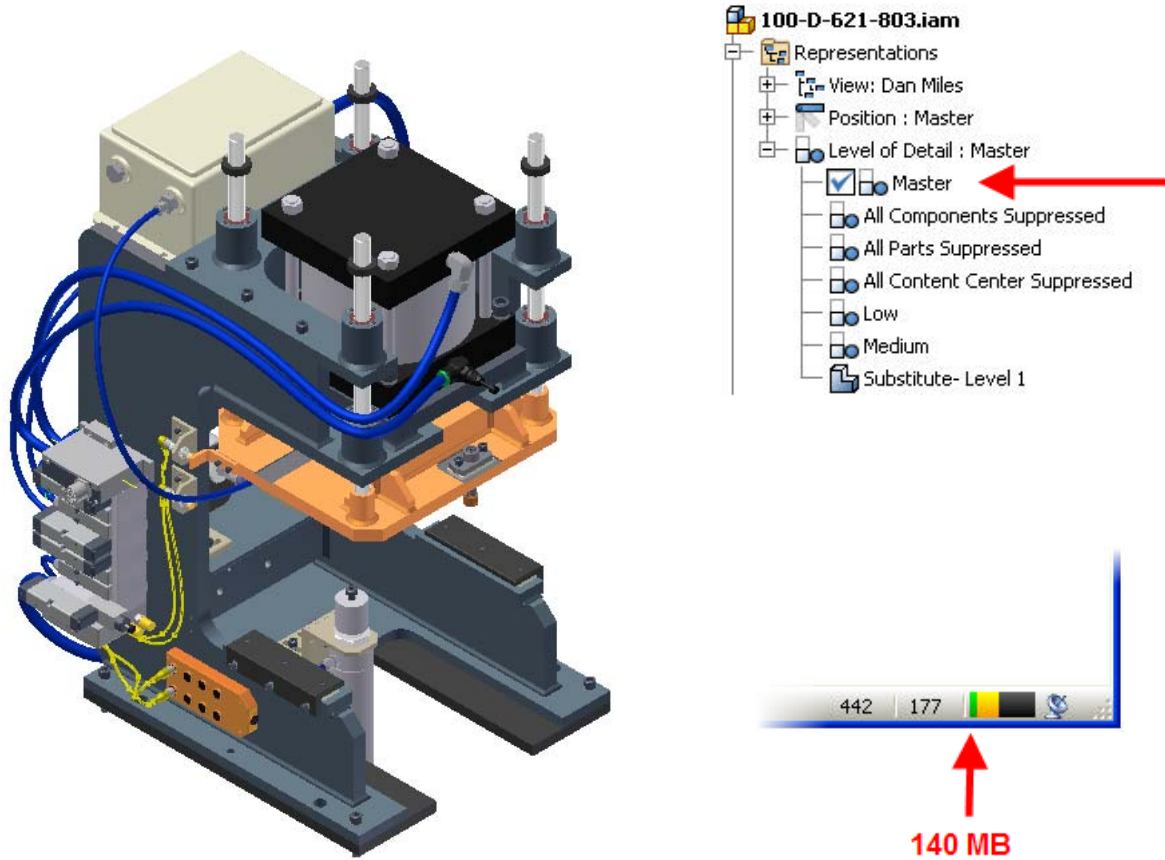

Memory Used	140 MB
Total Occurrences	442
Open Unique Documents	177

“Medium” Level of Detail

The “Medium” LOD contains fewer components in the un-suppressed state than the “Master” representation which improves performances and reduces memory. The following suggestions outline the types of components that are generally suppressed in the “Medium” LOD by the user:

- All internal and non-visible components.
- Complex components which do not contribute significantly to the overall geometry.
- Non critical fasteners or smaller components.

The image below illustrates an example of a “Medium” LOD.

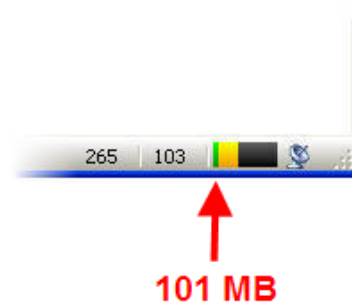
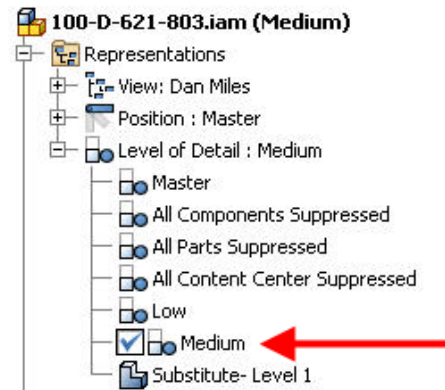
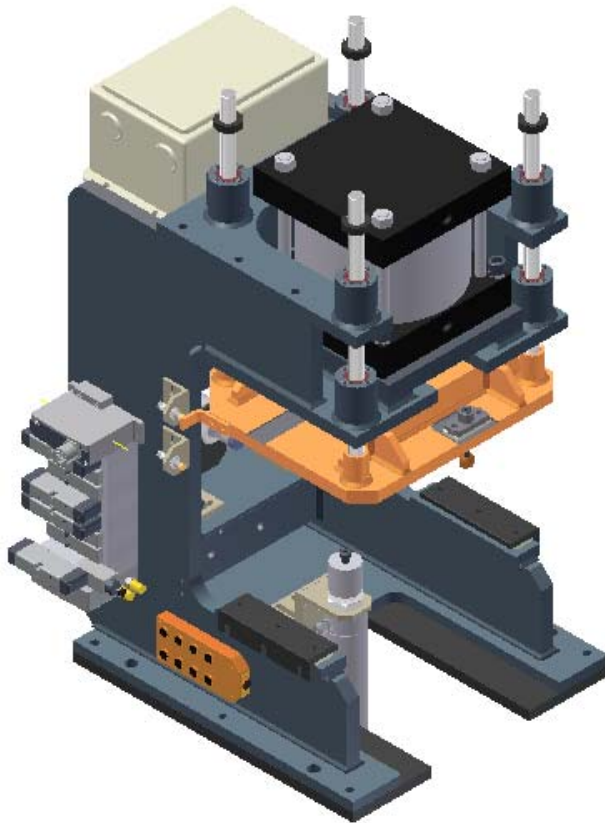

Memory Used	101 MB
Total Occurrences	265
Open Unique Documents	103

“Low” Level of Detail

The “Low” LOD contains only the most basic required components reducing the amount of memory needed. Generally speaking, this would contain fewer components than either the “Master” or “Medium LOD’s. The goal with the “Low” LOD is to remove all extraneous components, leaving only the most critical components to define the overall geometry.

The image below illustrates an example of a “Low” LOD.

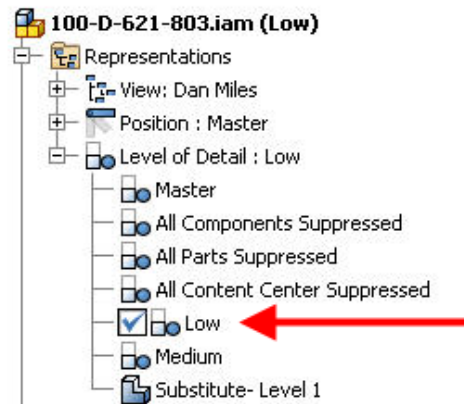
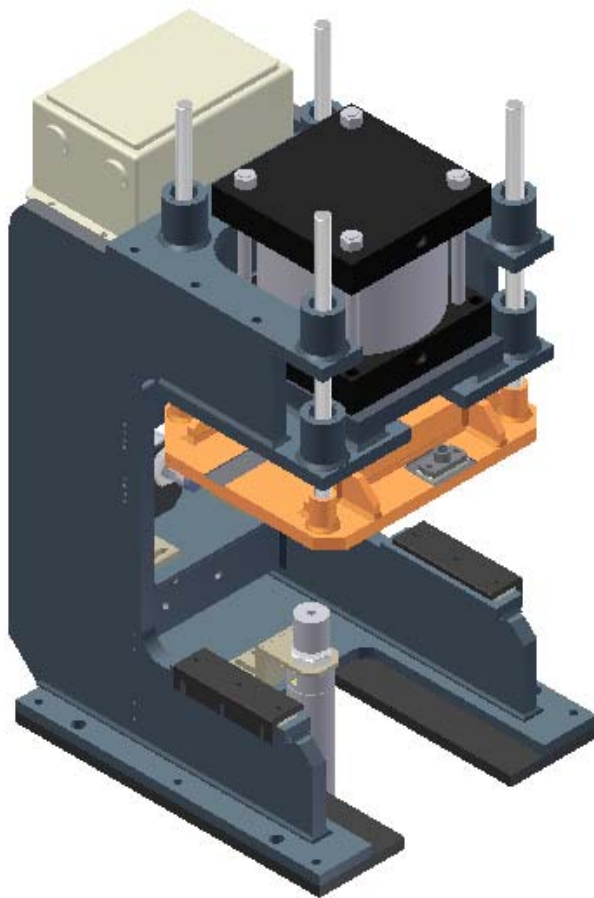

68 MB

Memory Used	68 MB
Total Occurrences	118
Open Unique Documents	73

“Substitute – Level 1” Level of Detail

The “Substitute – Level 1” LOD contains a part substitute for the assembly that was created using the memory saving mode option in derived part methodology. This is the lowest overhead LOD and still provides a good description of the assembly model for the designer. The goal with a substitute LOD is to shorten the assembly tree and reduce as much memory as possible.

The image below illustrates an example of a “Substitute – Level 1” LOD.

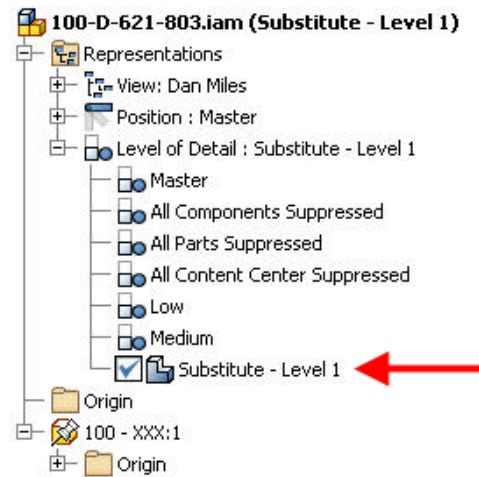
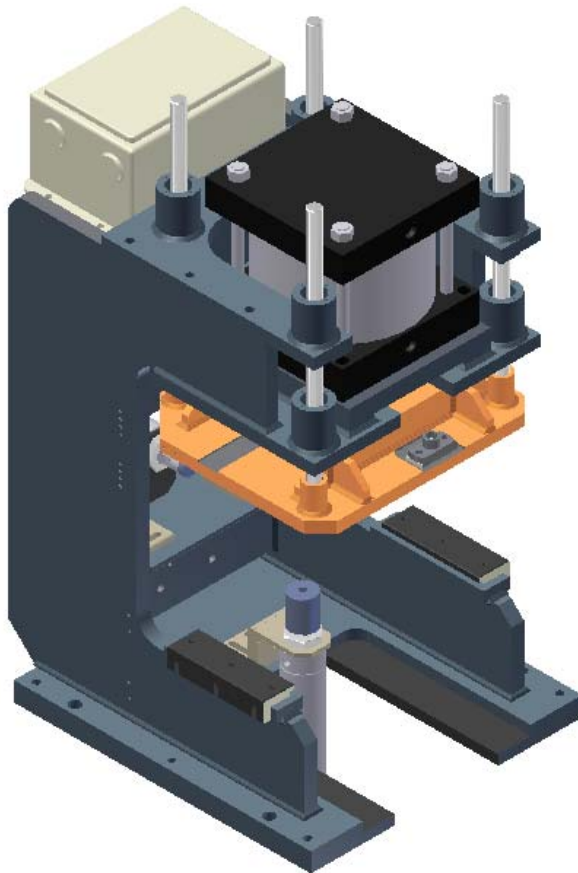

42 MB

Memory Used	42 MB
Total Occurrences	1
Open Unique Documents	2

Nested Levels of Detail

The real power of this standardized method is when sub-assemblies containing LOD's are incorporated. Here sub assemblies containing standard LOD representations are nested within a parent assembly using the same approach. For example, with the LOD presentations already created in each sub-assembly, Medium and Low LOD's for example can be created in the parent assembly that sync with those same designations in the sub-assembly.

The parent assemblies "Medium" Level of Detail representation would follow these guiding principles:

- All sub-assemblies active LOD set to "Medium"
- Suppress all internal and non-visible components within parent assembly following the same "Medium" suggestions in the previous section.

The parent assemblies "Low" Level of Detail representation would follow these guiding principles:

- All sub-assemblies active LOD would be set to "Low"
- Suppress all non critical components within parent assembly following the same "Low" suggestions in the previous section.

The beneficial effects of nested levels of detail are magnified by the number of levels of sub-assemblies in the design. When incorporating multiple levels of sub-assemblies, users must still follow the LOD conventions explained earlier for the parent assembly. In special cases, the Level of Detail states may be mixed to suit the user's needs. The benefits and effects of multiple nested Level of Detail approaches can be seen in the following illustration.

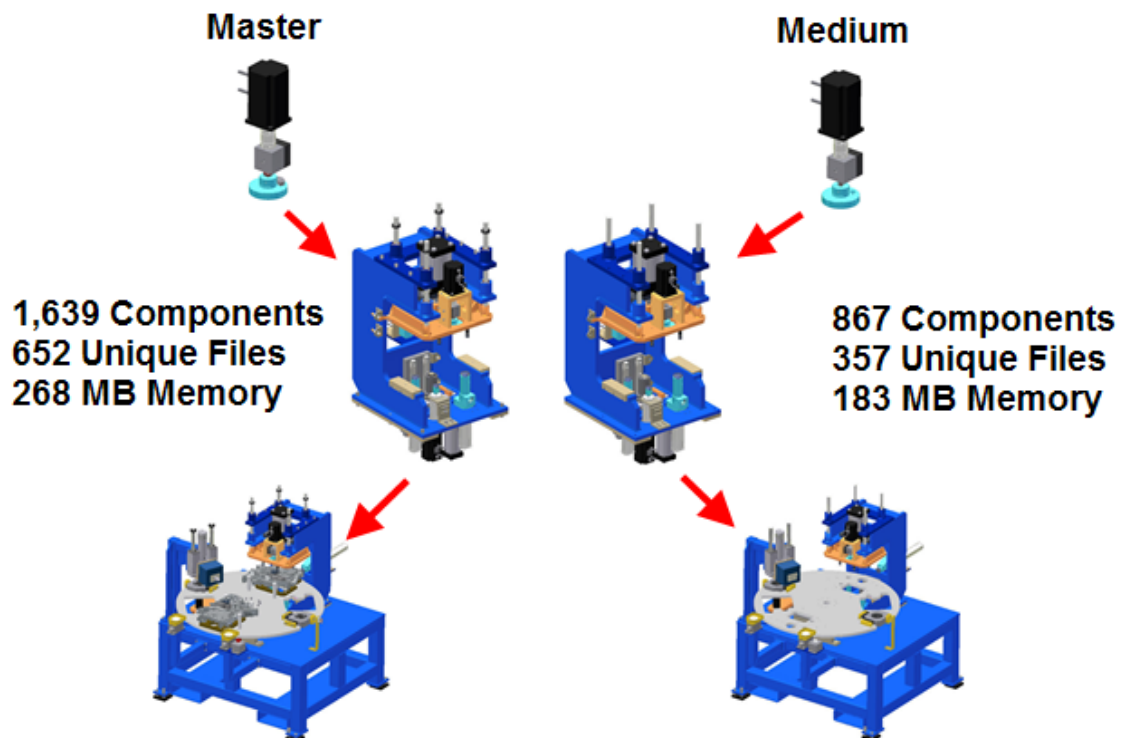

Part and Assembly Component Simplification

The amount of detail present in parts and assemblies dictates how “heavy” they are within large top level assemblies. Since you can only control so much using the settings within the Autodesk Inventor application to improve performance, and you are always looking to build something bigger, you need to take matters into your own hands. One way to do so is to reduce the amount of information Autodesk Inventor needs to process at the part and assembly level. This can be accomplished by creating simplified models. For manufacturing and documentation purposes, users need all of the detail for final production, but generally don’t need all of the information all of the time while designing. It is easy to find instances where designers have gone overboard with detail. This is common in purchase component items downloaded from websites.

So what does it mean to make a simplified 3D model? In most cases, the goal is to reduce the amount of faces and edges within the component. The amount of Inventor model features does play a role, but it generally is not a controlling factor as much as how many faces and edges there are to form the part model. By doing this, the files will reduce in file size which is a quick measure for how much pre-work has been completed. This will improve open and save times, reduce graphic overhead, reduce memory usage, and increase drawing view creation and edit performance.

In cases that have very complex parts or sub assemblies, you might want to consider creating three versions of each component with a different level of detail. The main version would be the full or “heavy” version that contains all of the detail. The medium version would not contain all of the detail, but would still contain most of the description of the component. The third version would be a very light version that only represents the general shape of the component. You may also choose to just create two versions if needed, one being the full version and the other the light version. These new component versions can be used having substitutes within the assembly as needed to increase performance. You can also use them in different Level of Detail (LOD) setups. Listed below are several examples of these methods:

Full Detailed Part (1,146 KB File Size)



Medium Detailed Part (520 KB File Size)



Low Detailed Part (186 KB File Size)



Autodesk Inventor®: Best Practices for Working with Large Assemblies (Digital Prototypes)

Full Detailed Assembly (442 Items – 140 MB Used)

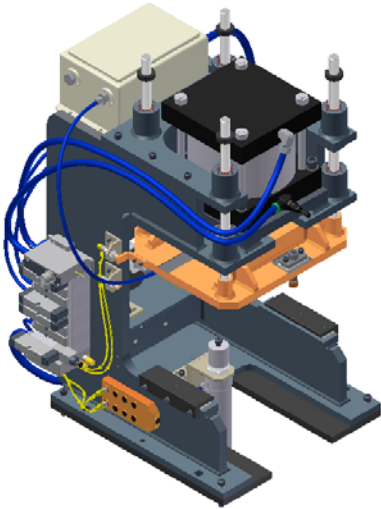

Part File Medium Detail (1 Item – 56 MB Used)

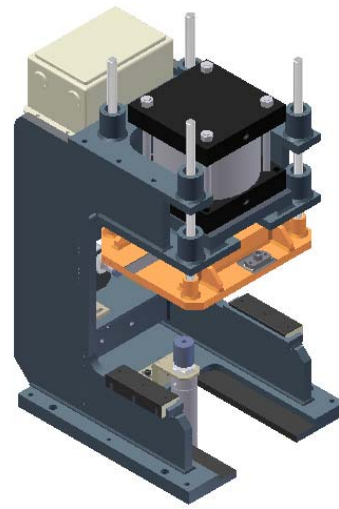

Another important item to avoid is unnecessary amounts of detail in the model. If the item is not needed, do not add the extra overhead. This also applies when you download a purchased component from a website that contains too much detail. If needed, take a few minutes to remove or cut off the unnecessary detail. Here is a small example of a fastener part model that contains information that is generally not needed:

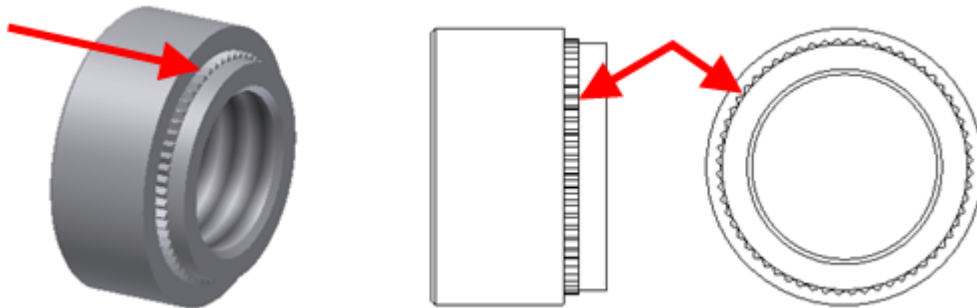

The two most important tools within Autodesk Inventor 2009 for creating simplified models of part and assemblies are the Derived Component and Shrinkwrap tools. The following sections will provide detailed information on these two tools to assist you with creating simplified models. These simplified models will be used within assembly substitutes in the form of Level of Detail's.

Derived Component Tool

The “Derived Component” tool within Autodesk Inventor has been available for several releases now but with the addition of the assembly substituting in release 2009 it has even a more important role now. Creating derived component part files is one of the main elements of substituting components.

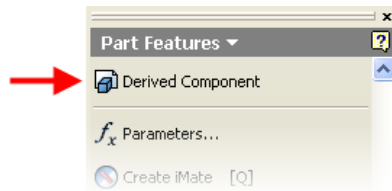

There are two main purposes for the Derived Component tool. The first purpose of this tool is to create simplified models and the other is for component Boolean operations. We will focus on the items important for creating simplified models for the purpose of this document. Autodesk has added a new option in Autodesk Inventor 2009 for reducing the memory required for derived components. The new option is available within the derived component dialog and is called “Reduced Memory Mode”. This reduces memory by not caching source bodies.

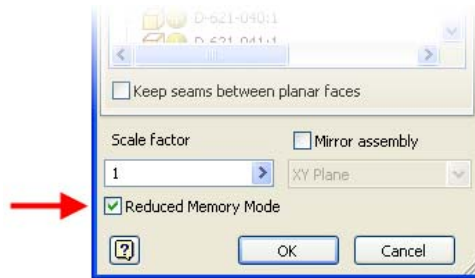

The 442 component assembly file below illustrates the memory savings that can be realized with this new option. By creating a derived component of this assembly with the “Reduced Memory Mode” option, the file size is only 11.3 MB. Without this option the derived component part file had a file size of 19.0 MB.

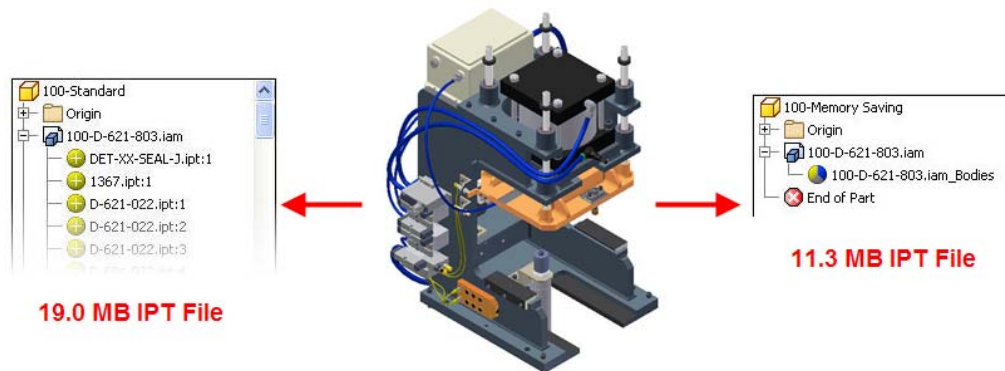

Autodesk Inventor®: Best Practices for Working with Large Assemblies (Digital Prototypes)

Another way to use the “Derived Component” command to simplify or reduce memory is to reduce the items displayed or used to create the new component. One of the best ways to do this is use the “File Open Options” to activate a Design View Representation or Level of Detail Representation during the master file section of the Derived Component creation process.

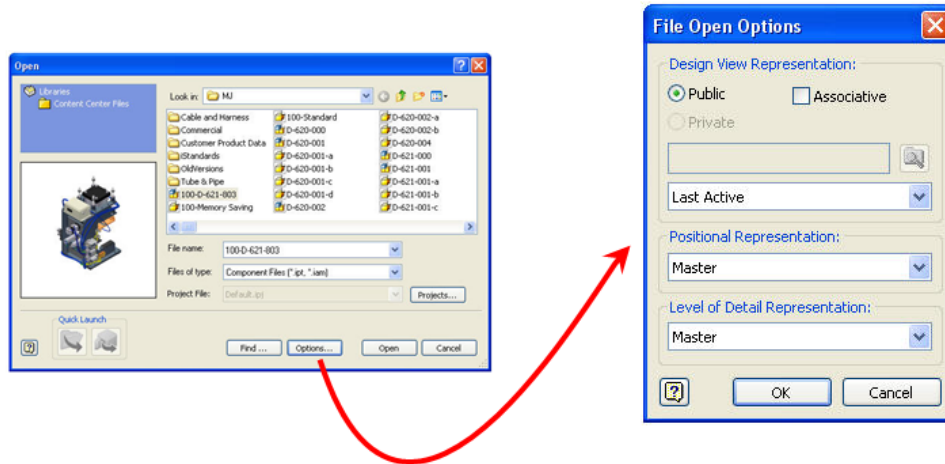

Creating a “Bounding Box” of a component simplifies a part or assembly to a rectangular box that is sized to the maximum dimensions of the file selected. This is one of the simplest items and is very small in file size. However, this often over simplifies the model and makes it unusable to the engineer. A bounding box component may be created by toggling the component status to use the Bounding Box option which is the green box as illustrated below.

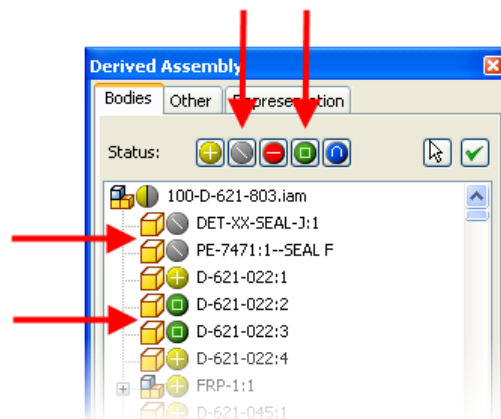

Note: The green box status icon is only available if you select an assembly file as the parent file.

Shrinkwrap Add-in Tool

The “Shrinkwrap Add-in” is a downloadable add-in for Autodesk Inventor from the Autodesk Labs website (<http://labs.autodesk.com>). This new tool takes advantage of the Inventor derived part workflow to create a standalone single part without interior geometry. By removing interior geometry from parts or assemblies the amount of detail can be greatly reduced without losing the outer shape of the component. Outlined below are the three main steps of creating an envelope part using the Shrinkwrap tool and the results.

Step 1 – Creating the Starting Single Part File

When starting with an assembly file you will first need to create a derived component by using the first icon within the Shrinkwrap toolbar. This will create a single part and break the link to the assembly. If starting with a part, this first step may be skipped and the user may proceed to step 2 to start filling the openings of the complex part.



Step 2 – Filling the Openings

To start filling the openings of the part, the second icon on the right of the Shrinkwrap toolbar must be used. This will display the main dialog box and provides you with three different options for filling the openings.

- **Close Face** – Used to close a planar face completely by removing all regions that are inside.
- **Extrude Face** – Used to extrude a planar face with the full features of the standard extrude tool.
- **Thicken Face** – Used to thicken or extend a face to close an opening between two items.

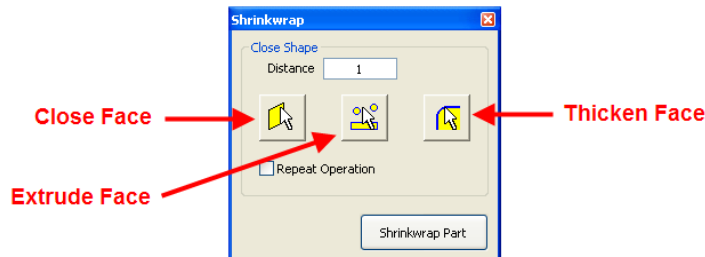

Step 3 – Creating the Final Envelope Part

Once all openings have been filled, select the “Shrinkwrap Part” button to create the final envelope part. The message box below will notify you of how many faces will be removed. Then a part file will be created that is not linked to any other files.

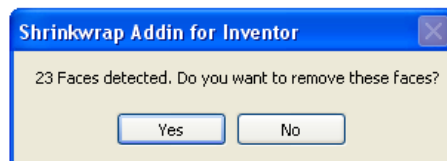

Autodesk Inventor®:

Best Practices for Working with Large Assemblies (Digital Prototypes)

The single part example below illustrates an excellent use of creating an envelope part to reduce memory and simplify a very complex casted component. This tool can also be used on assemblies to simplify them.

Complex Casted Part before Shrinkwrap

The IPT file before using the shrink wrap tool to fill in all of the openings.

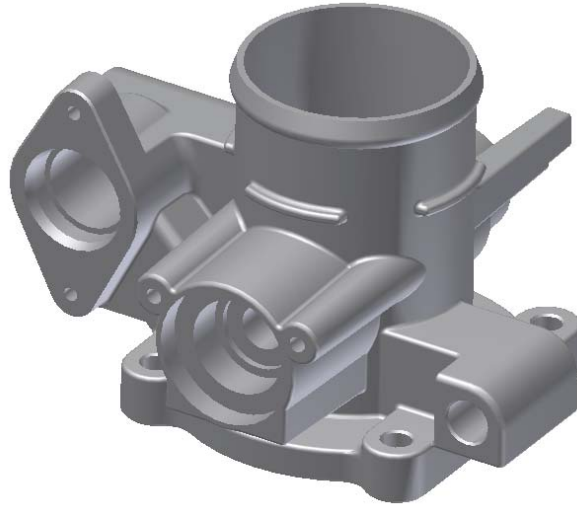

Envelope Casted Part after Shrinkwrap

The IPT file after using the shrink wrap tool to close all of the openings.

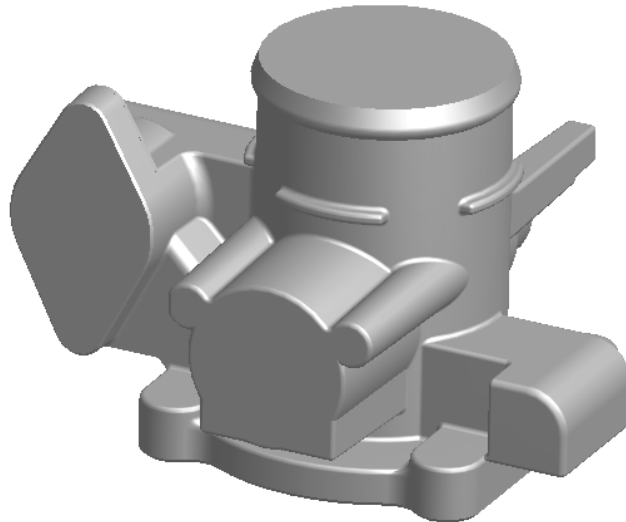

Component Colors

Using Autodesk Inventor, the color of any part at the assembly or part level can be changed. It is recommended with standard components that will be reused across projects or products that the part level color is set to one that is not highly reflective or shiny. The color of the components may be changed to a shiny color as needed at the assembly level. By reducing the amount of parts with a shiny color requiring a reflection image, the graphics overhead within the 3D environment will be less. This will increase the performance and quality of viewing tools like the zoom and rotate commands. Any color that has a setting of 50 or more may be considered a shiny color. You can control this shiny setting within the “Style and Standard Editor” as shown below.

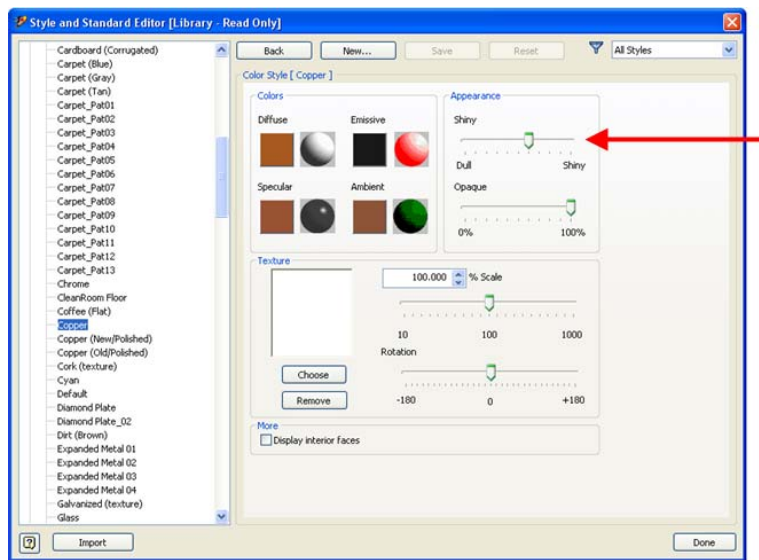

Creating “Flat” and “Shiny” versions of all the colors you use and those used by Autodesk Inventor materials is highly recommended. For example, the out of box copper material references the color called “Copper” which is a shiny one. Now every copper component you need is shiny even when you don’t need it. In this case, the style library should be configured to have two different copper materials. One called “Copper (Shiny)” which would have a shiny setting of 70. Then a second one called “Copper (Flat)” which would be set to a shiny setting of 30 and would also be the one referenced back to the Copper material within the style library.

Chrome Color (Shiny Setting of 86)



Metal – Steel Color (Shiny Setting of 25)



Drawing View Performance

The items outlined below will assist with increasing the performance of creating and editing drawing views.

Utilizing Level of Detail in Drawing View Creation

With the assemblies properly configured to include custom Level of Detail representations, the end user now has additional flexibility when creating 2D drawing views. Autodesk Inventor allows the user to specify which LOD state is used to create drawing views. Applying a LOD to the assembly files used for creating the drawing view, will reduce the amount of components Autodesk Inventor will need to solve for processing the 2D drawing view. This will increase the drawing view creation and edit times and reduce the amount of memory required.

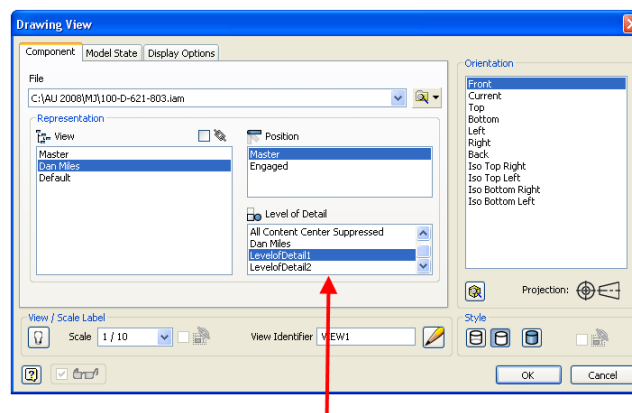

Note: Selecting the “Options” button within the open dialog box while selecting a file to use for the view creation can save some time generating the preview image of the view.

Controlling Hidden Line Display by Component

Hidden lines may be turned off for each individual component by right clicking on a component within a drawing view and de-selecting the hidden link option as shown below. This helps with creating nice looking, top level assembly drawings views that require an amount of detail between all hidden lines and no hidden lines.

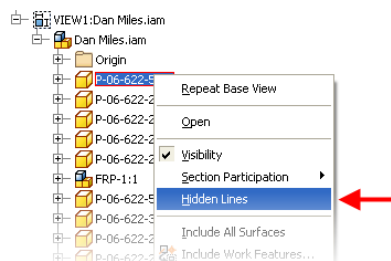

Defer Updates

Updating drawing views is the most time consuming and memory intensive operation within the drawing environment of Autodesk Inventor. Drawing view updates may be turned off by selecting the defer updates option under the Drawing tab of the document settings dialog. This is a per drawing file setting thus the user must access this option under the Tools pulldown menu by selecting Document Settings. Turning this option on is only recommended when working in large drawings. Always turn it back off before completing the final save of the drawing file.

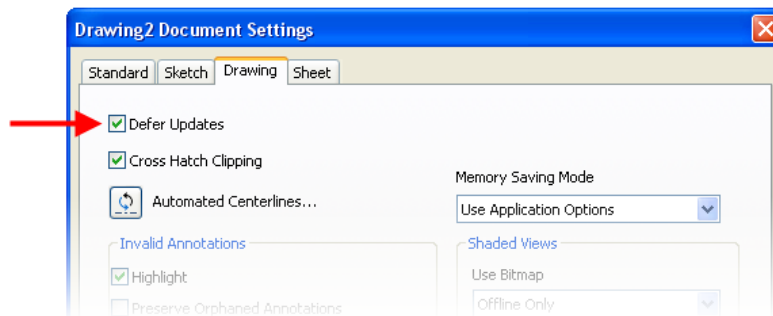

To increase drawing file open time the “Defer Updates” option may be selected from within the file Open dialog by selecting the Options button.

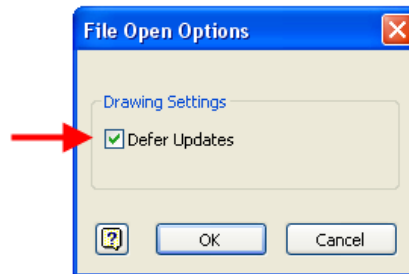

Note: Once done with the drawing and ready to release it always remember to turn off the defer update option. This will ensure that as people work with the files, the drawing views will always match the model. INCAT has specially built a program known as iCHECK for Autodesk Inventor to check for this exact scenario and over 80 similar quality issues automatically. To learn more about iCHECK visit www.incat.com/icheckinventor .

Assembly Structure

Generally the assembly structure within your models is determined by either your product structure or manufacturing processes. Often it is acceptable to add some assemblies and levels within large assemblies to help manage the data and provide capabilities to open different file sets and create custom Level of Detail representations easier. The two most common BOM Structure states for assisting with this are the “Reference” and “Phantom” states.

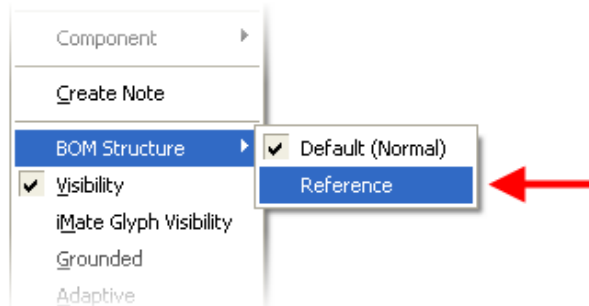

The Role of View Representations

View Representations are another useful tool for manipulating and managing large assemblies. View representations allow a user to store preset configurations of the component visibility settings and other settings enable and disable states. Also they store saved camera views for recalling specific viewing angles of your model. The main two benefits of View Representations are the reduction of graphical overhead within the 3D environment and an elimination of the amount of objects within a drawing view.

For example, a user may want to create a special View Representation to prepare for a later drawing view. If the user knows they will not need to display hidden lines in a front view, they may desire to eliminate the visibility of all components not necessary to produce that view. Using the advanced components selection tools greatly help with items like this especially the “All in Camera” method.

Tips

Outlined below are several tips for various items that will also help with working with large digital prototype assembly models.

Tip – Component Selection Tools

There are various advanced component selection tools available by right clicking on the graphics background within Autodesk Inventor and selecting the “Selection” menu fly out as shown below. These tools can be used to create LOD representations quicker.

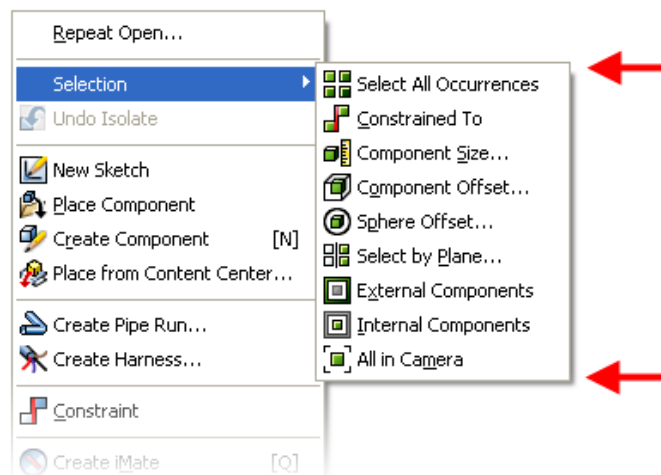

Example: The “Internal Components” selection type can be used to select all of the components that are within some other item. This is good for setting up some type of LOD or a derived component that would be used as a substitute.

Example: The “All in Camera” selection method is good for selecting everything that is visible within the screen at the current viewing direction. Once selected, the Shift key and Right Click may be pressed to “Invert Section” to turn off everything not in the camera. This is good for creating LOD’s or View Representations for drawing views of very large assemblies.

Tip - Utilizing Levels of Detail at File Open

One of the best ways to utilize Level of Detail representations is during the file open operation. This will ensure the least amount of memory is used providing the fastest way to open large assembly models and enabling you to load information in as you desire. Also with Autodesk Inventor 2009 with Autodesk Vault only the files used in the LOD will be copied from the Vault to your local workspace saving even more time. With the assemblies properly configured to include the Master, Medium, and Low LOD's, the end user now has the ability to select an LOD during the file open operation. Listed below is the process for doing this:

1. Select the “Options” button within the file open dialog box as shown below.

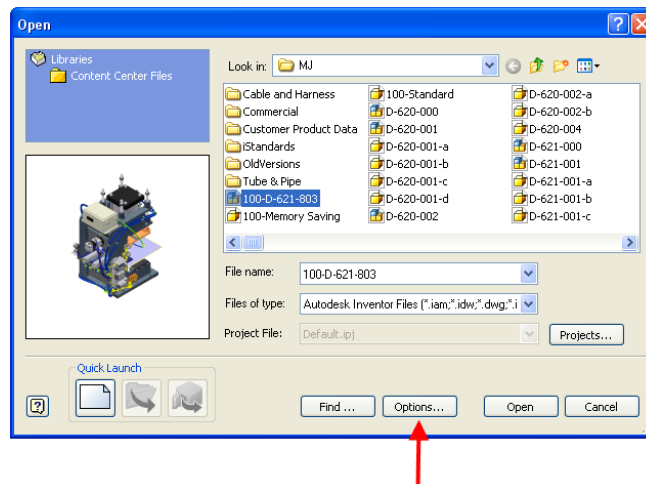

2. From within the file open options dialog, select which level of detail representation you would like to open as shown below.

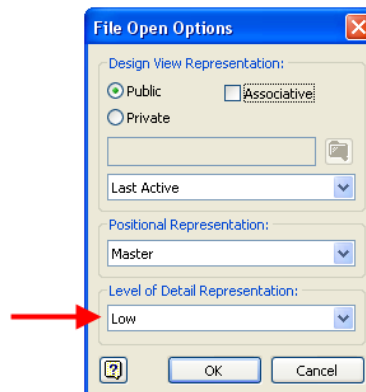

3. Click the “Ok” button in the File Open Options dialog then the “Open” button within the open dialog.

Autodesk Inventor®: Best Practices for Working with Large Assemblies (Digital Prototypes)

Tip – Using Parameters to Control Feature Suppression

One of the easiest ways to create different variations of a part that can be substituted for another part is to suppress part features. You can use a trick to control which features are suppressed by a custom model parameter making it easier to contain all information within a master file. The model parameter value can then be changed and the file saved as a new variation without managing two or more master files. Listed below is the high level process for this methodology:

1. Create a user model parameter called “Level_Of_Detail”. You will control which features are suppressed by either entering a value of “0” for full detail and “1” for low detail.

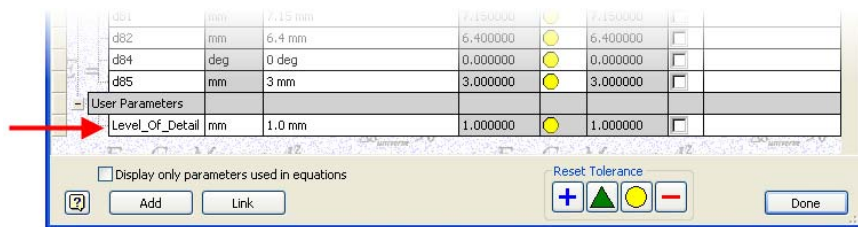

2. Go into the properties of each feature as needed by right clicking on the feature in the browser and selecting “Properties”.

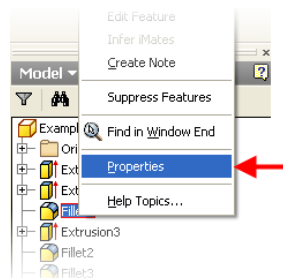

3. Under the suppress area of the feature properties setup an “If” condition that will suppress the feature if the “Level_Of_Detail” parameter is equal to 1. This process may be repeated for all of the required features.

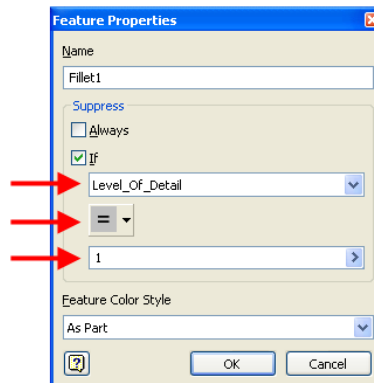

Summary

In conclusion, purpose-built tools have become part of the Autodesk Inventor product for managing and working with large assemblies that consist of thousands of components. However, to maximize effectiveness while using these tools, standard processes need to be implemented to ensure that desired productivity levels are achieved. Large assemblies can be very complex. To improve performance when opening or working with large 3D digital prototype assembly models, investments in technology can be made to greatly increase performances and scalability. Also utilizing the correct settings within Autodesk Inventor can also dramatically impact your performance and experience in a positive way.