

BIM-based Parametric Building Energy Performance Multi-Objective Optimization

Mohammad Rahmani Asl¹, Michael Bergin², Adam Menter³, Wei Yan⁴

¹PhD Candidate, Department of Architecture, Texas A&M University ²Research Scientist, Autodesk Inc. ³Sustainability Education Program Manager, Autodesk Inc. ⁴Associate Professor, Department of Architecture, Texas A&M University

¹<https://sites.google.com/site/bimsimgroup/people/students/mohammad-rahmani-asl>

²<http://www.autodeskresearch.com/people/michaelbergin> ³<http://www.adammenter.com/>

⁴<http://faculty.arch.tamu.edu/wyan/>

^{1,4}{mrah|wyan}@tamu.edu ^{2,3}{michael.bergin|adam.menter}@autodesk.com

Building energy performance assessments are complex multi-criteria problems. Appropriate tools that can help designers explore design alternatives and assess the energy performance for choosing the most appropriate alternative are in high demand. In this paper, we present a newly developed integrated parametric Building Information Modeling (BIM)-based system to interact with cloud-based whole building energy performance simulation and daylighting tools to optimize building energy performance using a Multi-Objective Optimization (MOO) algorithm. This system enables designers to explore design alternatives using a visual programming interface, while assessing the energy performance of the design models to search for the most appropriate design. A case study of minimizing the energy use while maximizing the appropriate daylighting level of a residential building is provided to showcase the utility of the system and its workflow.

Keywords: *Building Energy Performance Analysis, Building Information Model (BIM), Parametric Modelling, Parametric Energy Simulation, Multi-objective Optimization*

INTRODUCTION

Due to the considerable impact of buildings on the environment, it is essential for designers to recognize the importance of improving or optimizing building energy performance in the early design stage. Energy performance-based design is a highly complex and labor-intensive process. Designers deal with a complex Multi-Objective Optimization (MOO) prob-

lem to minimize capital and operating costs while maintaining occupants comfort (Wang et al., 2005; Wright et al., 2002). This complexity comes from the large number of interrelated parameters involved in sustainable building design such as building geometry, space layout, materials, sites, weather data, user behaviors, etc. There is a lack of easy-to-use and efficient tools to help architects explore design alterna-

tives and understand their impacts on building energy performance. Consequently, design practitioners either decide not to consider energy performance of their designs and instead follow general rules-of-thumbs, which may result in inefficient building designs, or seek help from building energy experts to simulate building design alternatives. Since transferring an architectural design model to an energy model is a time consuming and error-prone process, the designers and energy experts have to select a limited number of design alternatives for energy analysis, which result in unoptimized design solutions.

Current building energy modeling tools do not support comprehensive parametric relations among building objects for simulation in tools such as EnergyPlus. For instance, if a wall is transformed in an energy model, none of the related objects including windows, shading devices, rooms, roofs, and floors will be updated automatically. In other words, parametric intents that are embedded in parametric Building Information Modeling (BIM) are not embedded in the energy models. As a result, a manual update of the model data is needed before running the simulations but this is complex, tedious, and error-prone.

In order to fulfill the requirements of low energy building design there is a need for an innovative design methodology and integrated design process. The integration of parametric modeling and BIM is the new trend of building modeling, which can greatly benefit sustainable building design. Parametric modeling enables the creative exploration of a design space by varying parameters and their relationships (Azhar and Brown, 2009). BIM is a model-based process that provides methods and tools for creating and managing building projects faster and more economically (Eastman et al., 2011). BIM may contain most of the data needed for building energy performance analysis and if used appropriately can save a significant amount of time and effort in preparing input data for building energy simulation while reducing errors (Kumar, 2008).

In this paper we investigate a systematic integra-

tion of BIM, parametric modeling, and building performance analysis to provide a new workflow that makes the parametric building energy performance study more accessible for innovative energy efficient building design. The workflow uses a MOO algorithm to explore the design space and provide a set of optimal solutions to the designers.

BACKGROUND

The conventional architectural design methodologies focus on space and form. With the increasing importance of building energy-efficiency, designers have to consider energy performance of their design by exploring design alternatives that are more promising to save energy in the conceptual design phase (Azhar et al., 2009). A considerable amount of literature has been published on building energy simulation tools. For instance Maile et al. (2007) studied the use of a selection of energy simulation engines and their user interfaces over different building lifecycle phases. Also, Crawley et al. (2008) provided a comparison of the features and capabilities of twenty major building energy simulation tools. The literature review of this paper is focused on building energy simulation in conjunction with parametric modeling, BIM, multi-objective optimization, and visual programming, which are the techniques that are used in the developed integrated system.

Parametric Modeling and Building Energy Performance Analysis

One of the major benefits of performing energy simulation during the design process is to compare design alternatives using parameters and rules among objects. Parametric modeling enables generative form-making and form-finding on the basis of aesthetic and performance metrics of buildings. Once the contexts change in a later design stage, parametric modeling allows objects to automatically update (Aish and Woodbury, 2005; Stocking, 2009). Designers can integrate parametric modeling into the process of performance analysis in different fields of building design, including, but not limited to, energy simula-

tion (Paoletti et al., 2011; Pratt and Bosworth, 2011), structural analysis (Shea et al., 2005), and acoustic simulation (Wu and Clayton, 2013).

Parametric studies show a significant potential contribution to optimize the building energy performance (Naboni et al., 2013; Pratt and Bosworth, 2011). Nonetheless, designers rarely use parametric building energy performance analyses for the sake of due to the difficulty in preparing the energy models as well as the long simulation run time. To solve this issue, there are two common approaches: to develop computational algorithms that reduce the number of runs (Coley and Schukat, 2002; Wetter and Wright, 2004), or to increase the computational power through cloud-based simulation (Garg et al., 2010; Zhang and Korolija, 2010; Zhang, 2009).

BIM and Building Energy Performance Analysis

BIM is the process of generating and managing digital representations of the building's physical and functional characteristics to facilitate the exchange of information (Eastman et al., 2011). BIM represents the building as an integrated database of coordinated information that can be used for the analysis of the multiple performance criteria including architectural, structural, energy, acoustical, lighting, etc. (Fischer, 2006). Performance-based design supported by BIM is increasingly used in the building design disciplines, allowing practitioners efficiently generate and modify building models (Fischer, 2006; Welle et al., 2011).

The existing studies that consider BIM as the central data model for building energy performance analysis are mainly focused on automatic preparation of the building energy model for various energy simulation tools such as eQUEST (Maile et al., 2007), EnergyPlus (Maile et al., 2007; Bazjanac, 2008; Cormier et al., 2011), TRANSYS (Cormier et al., 2011), Ecotect and Green Building Studio (Azhar et al., 2009, 2011), and Modelica-based tools (Yan et al. 2013). The common approaches in this type of research is to translate the BIM models to energy input files for

solving interoperability issues using Industry Foundation Classes (IFC) (Bazjanac, 2008; Morrissey et al., 2004) and to create an automatic link between BIM authoring tools and building energy simulation engines (Yan et al. 2013).

Integration of BIM and parametric modeling provides a more effective process for performance-based design. Welle et al. (2011) created a thermal optimization tool, ThermalOpt, which used BIM for extracting the necessary information for thermal simulation and optimization. Rahmani et al. (2013) developed Revit2GBSOpt, a plug-in for a BIM platform (Autodesk Revit®), which integrates parametric BIM and building energy performance simulation. Due to the complexity of parametric design study, an easy and visual approach for designers to set up building parameters and the inclusion of advanced, open source MOO algorithms are needed to improve the existing studies, as presented in this paper.

Building Energy Performance Optimization

Optimization studies are being used in building design after long being computationally intractable, on multi-scale systems in various topics including optimizing construction costs (Radford and Gero, 1987), construction elements (Sambou et al., 2009), building shapes (Wang et al., 2006), building envelopes (Bouchlaghem, 2000; Radford and Gero, 1987), Heating, Ventilation, and Air Conditioning (HVAC) systems (Zhang et al., 2006), etc.

There are two common approaches to MOO problems: 1) simple aggregation 2) Pareto Optimal. In simple aggregation, a composite objective function is defined by combining all of the individual objective functions. The composite objective function can be determined with various methods, like use of weighting factors. Determining the composite objective function needs knowledge of the relationships among individual objectives and their weighting factors (Fonseca and Fleming, 1993; Konak et al., 2006). Nevertheless, in building design these relationships are unknown in many cases. The second approach is to seek a set of promising solutions,

known as Pareto-optimal set (Fonseca and Fleming, 1993), given multiple objectives. Pareto Optimality supports decision making by finding the equally optimal solutions such that it is not possible to improve a single individual objective without causing at least one other individual objective to become worse off (Hoes et al., 2011). A posteriori set of preferences may be used to evaluate the optimal solutions and find the unique solution later by the designers (Gossard et al., 2013; Konak et al., 2006).

Visual Programming

While computer programming is often needed for designers to implement their sophisticated design intent (e.g. through the use of for-loop and conditional statements) in parametric BIM, visual programming interfaces can replace the conventional elaborate coding with a visual metaphor of connecting small blocks of independent functionalities into a whole system or procedure (Boeykens and Neuckermans, 2009). Visual programming allows users create computer programs by manipulating program elements graphically rather than textually. Based on a survey of 50 visual programming languages (Myers, 1990), it is clear that a more visual style of programming could be easier to understand for non-programmers or novice programmers (architects normally fit into these categories). Examples of visual programming tools for architectural design are Grasshopper for McNeel Rhinoceros® and Dynamo for Autodesk Revit®.

METHODOLOGY

In this study an integrated system is developed for enabling designers to optimize multiple objectives in the early design process. A prototype of the system is created in an open-source visual programming application - Dynamo, which can interact with a BIM tool (Autodesk Revit®) to extend its parametric capabilities. The prototype contains a set of new function nodes that can be used to optimize building energy performance.

We have developed multiple Dynamo nodes to

contain essential functions for creating parametric BIM models in Revit and run parametric simulations in GBS. A MOO algorithm (Non-dominated Sorting Genetic Algorithm-II or NSGA-II, Deb et al., 2002) is created in Dynamo as a package of nodes that can help designers optimize multiple conflicting objectives and approach to a set of optimal solutions. The NSGA-II node package is built based on the open source code [1]. The node "NSGA-II" in Dynamo includes a package of nodes and plays the main loop role for population generation in MOO to get to the optimal solution (figure 1). The node "Initial Solution Set" generates the initial set of random variables within the provided range and with the size of population defined by user. The output of this node is a list of variables and objective. The objective values are null and they are assigned by "Population Evaluate" node which gets objective values as input parameters.

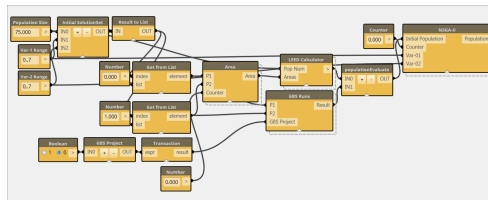

Figure 1
Implementation of NSGA-II in Dynamo to optimize daylighting and energy use

This workflow enables the Dynamo code to accept objective functions as nodes or packages of nodes. For instance, in this study the "LEED Daylighting" node is created as a package of nodes to calculate the LEED daylight values based on LEED Reference Guide for Green Building Design and Construction (USGBC, 2009) as an objective function.

The node "gbXMLExport" in Dynamo generates energy model data in the Green Building eXtended Markup Language (gbXML, 2014) format, which contains the necessary information for energy simulation, using Revit's Application Programming Interface (API). The "GBSProject" node is designed to create a new project in GBS by extracting the project information from a BIM model such as the project location and the building type using Revit API, GBS API, and the Representational State Transfer (REST) pro-

Figure 3
Case study building
site and floor plans

toloc. "GBSRun" is designed to create multiple runs in the GBS project and upload the exported gbXML files to GBS for whole building energy analysis. When the simulations are done, GBSRun retrieves the energy simulation results for further analysis, optimization, and visualization (figure 2).

Figure 2
Parametric BIM and
whole building
energy simulation
integration in
Dynamo

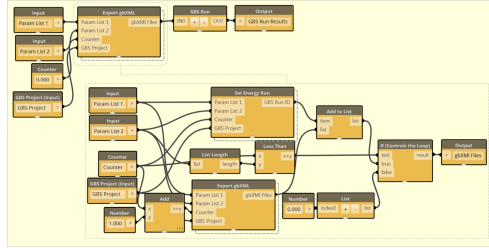

The presented system enables designers to explore design alternatives and at the same time assess the building performance to search for the most appropriate design.

CASE STUDY

The objectives of the optimization routine for this case study is to maximize the number of rooms of the residential unit that satisfy the requirements of the LEED IEQ Credit 8.1 for Daylighting while minimizing the expected energy use. The simulation and calculation of the energy use requires building information that BIM can provide, for example geometry information, physical material information, and location data embedded within the model. The workflows developed in this project can identify parameters from elements within the BIM and explore a set of scenarios for energy performance and daylighting adequacy.

Climate and Context

The geographic location of the home is in the city of Indianapolis, Indiana, USA. The climate is dominated by heating loads with 5892 Heating Degree Days (HDD) on a yearly basis. Due to site constraints, the long-axis orientation of the structure is fixed at 15 degrees west of true north (figure 3).

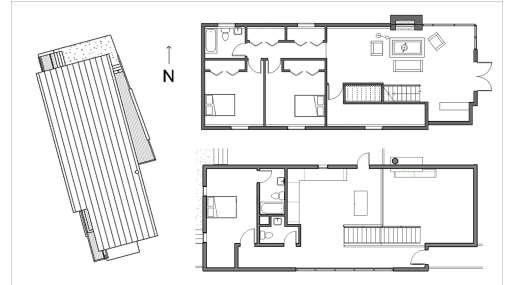

Model and Free Parameters (Decision Variables)

The residential home has six rooms at level one and two rooms at the second level that are included as part of the daylighting calculation and energy use for the entire building. The light admitted to the building can enter via two fixed curtain walls that are not included as free parameters in the design space optimization. These two curtain systems light the main living space in the first floor and the balcony in second floor. The rooms separated from the main living space by interior partitions are lit naturally by fixed windows with a visual transmission coefficient of 0.9. The width and height of the windows are identified within the Dynamo interface as free parameters. The domains of the width and height of the glazing area are set independently from 0.5' to 7.0' with an increment of 0.1'.

Optimization Algorithm

The NSGA-II algorithm is implemented with the input of a population size of 100 for each generation, with the maximum evaluations set at 1000 for a total of 10 generations. The mutation probability is set at 0.01. The crossover probability is set at 0.9 and both the mutation distribution index and crossover distribution index are set at 20.0. Figure 4 shows the general overview of the MOO system designed for this study and figure 1 shows its implementation in Dynamo to optimize daylighting and energy use of the building. The Pareto Optimal set from the NSGA-II algorithm is shown in figure 5. This graph shows the

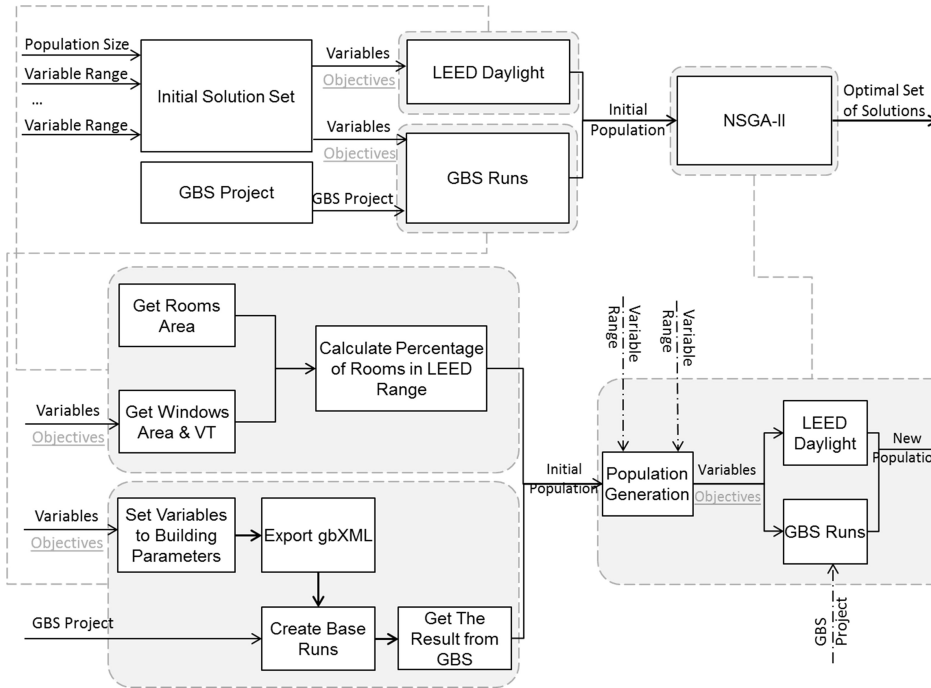

Figure 4
General overview of the designed MOO system

result for 1000 runs for this experiment which took about 3 hours overall. This graph indicates that the optimization routine begins to converge on the optimal solution for each variable from the third generation onward. From the graph in figure 6 it can be seen that windows of various Widths from 1' to 7' meet the requirements for more than 80% of the rooms correlating with about \$150 in variation for the yearly energy cost. In this instance, windows between the sizes of 3' and 4' in Height are evaluated, as this parameter is preferred for the reason of style to fit with immutable horizontal datum elements. For design variations within the bottom 30% of energy cost and the full satisfaction of the daylighting metric, the smallest glazing Width is specified at 2' 8".

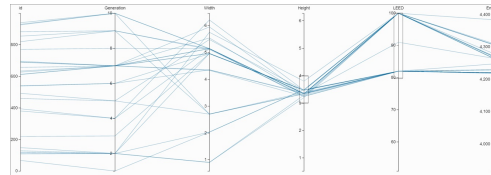
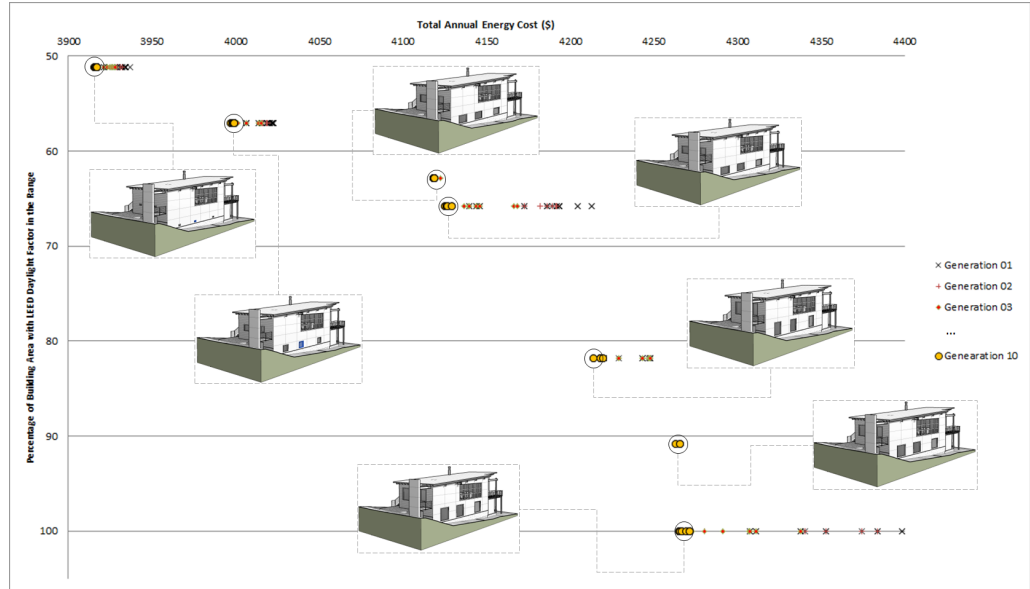

Figure 6
Interactive parallel coordinates plot for the constraint and analysis of design parameters.

Visualizing the results in an interactive parallel coordinates plot allows the various iterations to be evaluated by the designer. In figure 7 the chart shows the sample of design variations that meet 100% of the LEED Daylighting requirements. Of these the lowest energy use calculated is \$4,265 and the smallest window size is specified as a 5' width and 3.5' height.

Figure 5
Scatterplot showing the Pareto Frontier with model thumbnails superimposed on the plot to illustrate the association between the calculated optimal solutions and the building forms.



CONCLUSION

The investigation shows that the use of a BIM model to generate a multiplicity of parametric design variations for simulated and procedural analysis is a viable workflow for designers seeking to understand trade-offs between daylighting and energy use. The availability of a cloud-based energy analysis tool enables the quick evaluation of hundreds of design variations and the connection to a visual, parametric programming environment allows the design space to be quickly and accurately specified.

Designers with limited parametric modeling and programming experience may use the nodes produced to perform a broad variety of design space analyses. It is possible to optimize each window's width and height individually though this method expands the design space considerably. It is also possible to include the angle of the building orientation and the overall building footprint in the set of free parameters to be modified. For a broader design space the number of iterations required may be significantly increased to obtain reliable optimization

results.

In addition to local variables such as window dimensions and material variations this system is capable of producing design options in global building geometries such as the footprint, the form of the roof, and the interior layouts. These design options are considered often by architects and engineers in the design process. The information embedded within the BIM can quickly be leveraged to obtain quantifiable sensitivity of the performative implications to a broad set of possible design decisions.

Through the continued development of similar projects to enable fast BIM-based simulation and representation of solution spaces and trade-offs, designers may be able to understand dependencies of design options on the decision variables at the early design stage without substantial expertise in energy modeling and daylighting analysis. For parametric analysis, large changes in global building geometry can lead to alterations in structural requirements and mechanical systems as well. Incorporating a broader variety of simulations in different domains into the

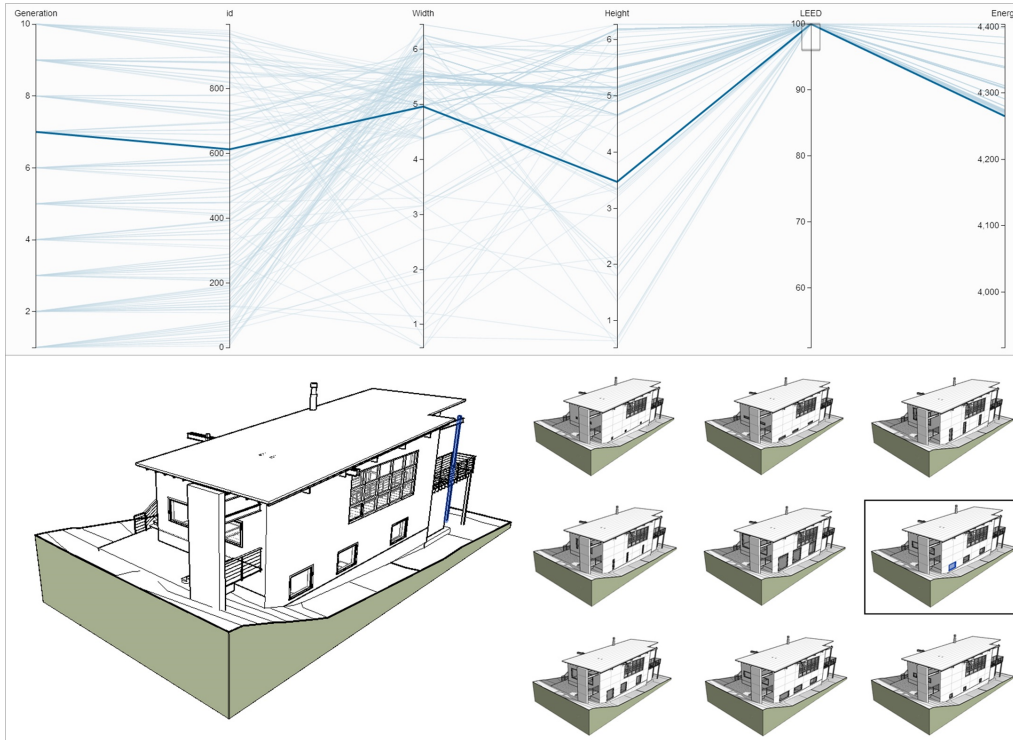

Figure 7
Illustration of a
bi-directional
association
between parallel
coordinates and 3D
model views

system will lead to more comprehensive exploration of the solution space and provide better decision support for the stakeholders of building construction.

Acknowledgment

This research is partially supported by the National Science Foundation under Grant No. 0967446. We would like to acknowledge and thank Autodesk Inc.'s Building Performance Analysis and Dynamo teams, and all who contributed to our research for all their help and support. Also, we would like to thank Alexander Stoupine at Texas A&M University for his contribution in this project.

REFERENCES

- Aish, R and Woodbury, R 2005, 'Multi-level interaction in parametric design', *Smart Graphics*, 3638, p. 151-162
- Azhar, S and Brown, J 2009, 'BIM for Sustainability Analyses', *International Journal of Construction Education and Research*, 5, pp. 276-292
- Azhar, S, Brown, J and Farooqui, R 2009 'BIM-based sustainability analysis: An evaluation of building performance analysis software', *45th ASC Annual Conference*, pp. 1-4
- Bazjanac, V 2008 'IFC BIM-based methodology for semi-automated building energy performance simulation', *Improving the Management of Construction Projects through IT Adoption, CIB W78, Universidad de Talca*, pp. 292-299

- Boeykens, S and Neuckermans, H 2009 'Visual Programming in Architecture: Should Architects Be Trained As Programmers?', *CAAD-Futures*
- Bouchlaghem, N 2000, 'Optimizing the design of building envelopes for thermal performance', *Automation in Construction*, 10, pp. 101-112
- Coley, DA and Schukat, S 2002, 'Low-energy design: combining computer-based optimization and human judgement', *Building and Environment*, 37, pp. 1241-1247
- Cormier, A, Robert, S, Roger, P, Stephan, L and Wurtz, E 2011 'Towards a BIM-based service oriented platform: application to building energy performance simulation', *Building Simulation 2011*
- Council, USGB 2009, *LEED Reference Guide For Green Building Design And Construction*, US Green Building Council (USGBC)
- Crawley, DB, Hand, JW, Kummert, M and Griffith, BT 2008, 'Contrasting the capabilities of building energy performance simulation programs', *Building and Environment*, 43, pp. 661-673
- Deb, K, Pratap, A, Agarwal, S and Meyarivan, T 2002, 'A fast and elitist multiobjective genetic algorithm: NSGA-II', *IEEE Trans. Evol. Comput.*, 6, p. 182-197
- Eastman, C, Teicholz, P, Sacks, R and Liston, K 2011, *BIM Handbook: A Guide to Building Information Modeling for Owners, Managers, Designers, Engineers and Contractors*, Wiley
- Fischer, M 2006 'Formalizing construction knowledge for concurrent performance-based design', *13th international conference on Intelligent Computing in Engineering and Architecture*, pp. 186-205
- Fonseca, CM and Fleming, PJ 1993, 'Genetic Algorithms for Multiobjective Optimization: Formulation, Discussion and Generalization', *JCGA*, 93, pp. 416-423
- Garg, V, Chandrasen, K, Tetali, S and Mathur, J 2010 'EnergyPlus Simulation Speedup Using Data Parallelization Concept', *AMSE 2010 4th International Conference on Energy Sustainability*, pp. 1-6
- Gossard, D, Lartigue, B and Thellier, F 2013, 'Multi-objective optimization of a building envelope for thermal performance using genetic algorithms and artificial neural network', *Energy and Buildings*, 67, pp. 253-260
- Hoes, P, Trcka, M, Hensen, J and Bonnema, B 2011 'Optimizing building designs using a robustness indicator with respect to user behavior', *Building Simulation Proceedings of the 12th Conference of the International Building Performance Simulation Association*, pp. 1710-1717
- Konak, A, Coit, DW and Smith, AE 2006, 'Multi-objective optimization using genetic algorithms: A tutorial', *Reliability Engineering & System Safety*, 91, p. 992-1007
- Kumar, S 2008, *Interoperability between building information models (BIM) and energy analysis programs*, Master's Thesis, University of Southern California
- Maile, T, Fischer, M and Bazjanac, V 2007, 'Building energy performance simulation tools-a life-cycle and interoperable perspective', *Center for Integrated Facility Engineering (CIFE) Working Paper*, 107, pp. 1-49
- Morrissey, E, O'Donnell, J, Keane, M and Bazjanac, V 2004 'Specification and implementation of IFC based performance metrics to support building life cycle assessment of hybrid energy systems', *Building Sustainability and Performance Through Simulation*, Boulder, Colorado, USA
- Myers, BA 1990, 'Taxonomies of visual programming and program visualization', *Journal of Visual Languages & Computing*, 1, pp. 97-123
- Naboni, E, Zhang, Y, Maccarini, A, Hirsch, E and Lezzi, D 2013 'Extending the use of parametric simulation in practice through a cloud based online service', *BPSA - Conference of International Building Performance Simulation Association*, Bozen, Italy
- Paoletti, G, Avesani, S, Exner, D and Lollini, R 2011 'Designing low energy buildings: application of a parametric tool and case studies', *27th International Conference on Passive and Low Energy Architecture*, Louvain La Neuve, Belgium
- Pratt, KB and Bosworth, DE 2011 'A method for the design and analysis of parametric building energy models', *International Building Performance*

- Simulation Association Conference—Building Simulation*
- Radford, AD and Gero, JS 1987, *Design by optimization in architecture, building, and construction*, John Wiley & Sons, Inc.
- Rahmani, m, Zarrinmeh, S and Yan, W 2013 'Towards BIM-based Parametric Building Energy Performance Optimization', *33rd Annual Conference of the Association for Computer Aided Design in Architecture (ACADIA)*, Cambridge, Ontario, Canada, pp. 101-108
- Sambou, V, Lartigue, B, Monchoux, F and Adj, M 2009, 'Thermal optimization of multilayered walls using genetic algorithms', *Energy and Buildings*, 41, pp. 1031-1036
- Shea, K, Aish, R and Gourtovaia, M 2005, 'Towards integrated performance-driven generative design tools', *Automation in Construction*, 14, pp. 253-264
- Stocking, AW 2009 'Generative Design Is Changing the Face of Architecture', *Building Design*
- Wang, W, Rivard, H and Zmeureanu, R 2006, 'Floor shape optimization for green building design', *Advanced Engineering Informatics*, 20, pp. 363-378
- Wang, W, Zmeureanu, R and Rivard, H 2005, 'Applying multi-objective genetic algorithms in green building design optimization', *Building and Environment*, 40, p. 1512–1525
- Welle, B, Haymaker, J and Rogers, Z 2011, 'ThermalOpt: A methodology for automated BIM-based multidisciplinary thermal simulation for use in optimization environments', *Building Simulation*, 4, p. 293–313
- Wetter, M and Wright, J 2004, 'A comparison of deterministic and probabilistic optimization algorithms for nonsmooth simulation-based optimization', *Building and Environment*, 39, p. 989–999
- Wright, JA, Loosemore, HA and Farmani, R 2002, 'Optimization of building thermal design and control by multi-criterion genetic algorithm', *Energy and Buildings*, 34, pp. 959-972
- Wu, C and Clayton, M 2013 'BIM-based acoustic simulation Framework', *30th CIB W78 International Conference*, Beijing, China
- Yan, W, Clayton, M, Haberl, J, Jeong, W, Kim, JB, Kota, S, Alcocer, JLB and Dixit, M 2013 'Interfacing BIM with Building Thermal and Daylighting Modeling', *13th International Conference of the International Building Performance Simulation Association (IBPSA)*, Chambéry, France, p. 3521–3528
- Zhang, Y 2009 "'Parallel" EnergyPlus and the development of a parametric analysis tool', *IBPSA Conference*, p. 1382–1388
- Zhang, Y and Korolija, I 2010 'Performing complex parametric simulations with jEPlus', *Proceedings of the 9th SET Conference*, Shanghai, China
- Zhang, Y, Lin, K, Zhang, Q and Di, H 2006, 'Ideal thermophysical properties for free-cooling (or heating) buildings with constant thermal physical property material', *Energy and Buildings*, 38, pp. 1164-1170

[1] <http://jmetalnet.sourceforge.net/index.html>